

# Removal of ECG Baseline Wander when Recorded by a 24-bit ADC Using a Resting Cycle Template <sup>†</sup>

Eladio Altamira-Colado <sup>\*</sup>, Miguel Bravo-Zanoguera, Daniel Cuevas-González, Marco Reyna-Carranza and Roberto López-Avitia

Facultad de Ingeniería, Universidad Autónoma de Baja California, Mexicali 21280, CP, Mexico; mbravo@uabc.edu.mx (M.B.-Z.); cuevas.daniel@uabc.edu.mx (D.C.-G.); mreyna@uabc.edu.mx (M.R.-C.); ravitia@uabc.edu.mx (R.L.-A.)

<sup>\*</sup> Correspondence: ealtamira@uabc.edu.mx

<sup>†</sup> Presented at 8th International Electronic Conference on Sensors and Applications, 1–15 November 2021; Available online: <https://ecsa-8.sciforum.net>.

**Abstract:** The development of electrocardiogram (ECG) wearable devices has increase due to its applications on ambulatory patients. ECG signals provide useful information about the heart behavior, but when daily activities are monitored, motion artifacts are introduced producing saturation of the signal, thus losing the information. The typical resolution used to record ECG signals is of maximum 16-bit, which might not be enough to detect low-amplitude potentials and at the same time avoid saturation due to baseline wander, since this last issue demands a low-gain signal chain. A 24-bit resolution provides a more detailed ECG signal under a low gain input, and if the signal is corrupted by motion artifact noise but is not saturated, it can be filtered to recover the signal of interest. On this work, a 24-bit ADC is used to record the ECG, and a new method, the rest ECG cycle template, is proposed to remove the baseline wander. This new method is compared to high-pass filter and spline interpolation methods in their ability to remove baseline wander. This new method presumes that a user is able to stablish a rest ECG during his/her daily activities.

**Keywords:** motion artifact; high-resolution microcontroller; portable ECG; signal processing; baseline wander removal

**Citation:** Altamira-Colado, E.; Bravo-Zanoguera, M.; Cuevas-González, D.; Reyna-Carranza, M.; López-Avitia, R. Removal of ECG Baseline Wander when Recorded by a 24-bit ADC Using a Resting Cycle Template. **2021**, *3*, x. <https://doi.org/10.3390/xxxxx>

Academic Editor: Eladio Altamira Colado

Published: date

**Publisher's Note:** MDPI stays neutral with regard to jurisdictional claims in published maps and institutional affiliations.



**Copyright:** © 2021 by the authors. Submitted for possible open access publication under the terms and conditions of the Creative Commons Attribution (CC BY) license (<https://creativecommons.org/licenses/by/4.0/>).

## 1. Introduction

The electrocardiogram (ECG) provides information about a patient heart electrical behavior and it is frequently measured placing electrodes on the skin surface [1]. The ECG can be measured by wearable sensors, allowing detection to be done during physical activity [2]. At any rate, the raw ECG signal might not be useful when noise affects the information contained. Therefore, denoising an ECG signal is necessary before an appropriate interpretation can be made.

ECG is susceptible to noise from different sources, being baseline wander (BW) one that is commonly induced by the patient's breathing and movement activity. BW is an undesired low-frequency component that would interfere in the signal interpretation. The removal methods for this type of noise normally include polynomial splining and high-pass frequency filters [3].

The usage of high-pass filters is a widely applied method to remove BW from a signal. However, they might remove useful low-frequency information, as well as depress the P and T waves; therefore, other methods to remove BW are preferred [4]. Other methods look to replicate the BW trend to subtract it from the ECG signal, leaving the signal of interest useful information. Some methods to replicate the BW trend include spline interpolation, which accuracy increases as the number of interpolated points increases [5].

With a methodology for a rapid prototyping of an ECG device, motion artifacts inherent in mobile health devices, as the ones occurring from wearable ECG sensors, were previously studied using high-resolution measure devices [6]. The objective of this present work was to use this same rapid prototyping platform to identify a new method to replicate the BW trend using an ECG rest cycle template and compare it with a high-pass filter and a spline interpolation methods; as a consideration of processing a noisy signal acquired by a high-resolution (24 bits) wearable system.

The ECG noisy signal was processed by the three methods: using a resting cycle template, spline interpolation, and second-order butterworth filter. Statistics and visual observations on the resulting signal were assessed after each method was applied. This new resting cycle template method presents a good performance and presumes that a user is able to establish a rest ECG during his/her daily activities.

## 2. Materials and Methods

On this section, the signal acquisition and processing methods are described, as well as the human volunteer specifications.

### 2.1. Rapid Prototyping Platform and Signal Acquisition

The signal used in this work was acquired from a human volunteer on a treadmill using a system built on a previous work [6]: Figure 1 shows the block diagram of the wearable device test platform used to acquire the signal. The AD8232 board used was the cardiac monitor provided by the manufacturer Sparkfun [7]. The C8051F350 microcontroller was used on a development kit provided by the Silicon Labs company. These modules and the HC-05 module serve as breakout box for rapid prototyping.

Subject specifications: healthy male, height 1.77 m, 23 years old, weight of 61 kg, electrical axis of the heart position: 120 degrees, DII registered lead: IN+ corresponding right arm (RA), IN- corresponding right leg (RL), and corresponding reference left arm (LA) [6].

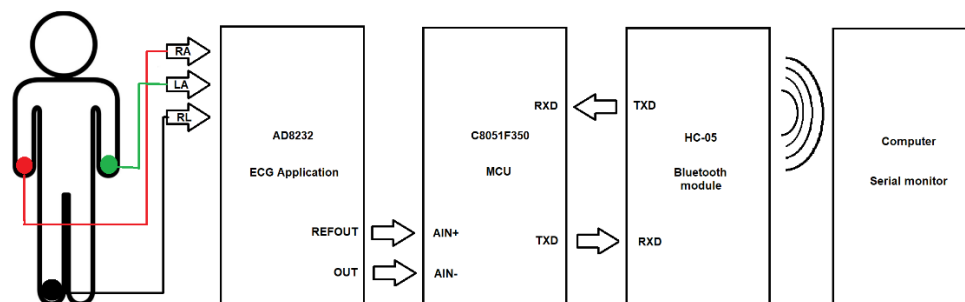

Figure 1. block diagram of high-resolution rapid prototyping platform for wearable devices.

The signal was acquired during a stationary gait with sudden movement to induce BW. The volunteer started on a rest position on their feet before the beginning of the stationary gait. Arduino serial monitor software was used to acquire the signal on a computer using a 115200 baud rate, with a 180 Hz sampling rate for the internal C8051F350 ADC, and using the AD8232 with a 100× gain [6]. The recorded signal to be processed is shown in Figure 2.

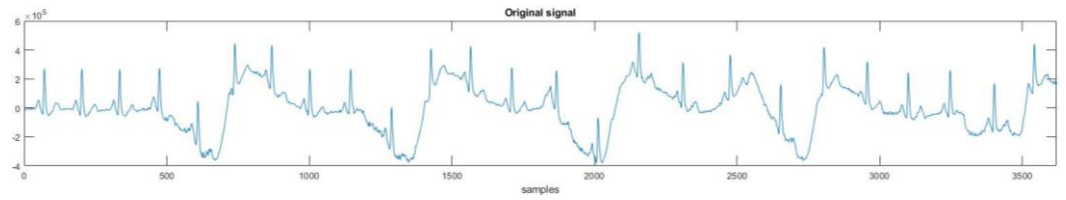

Figure 2. Original recorded signal.

### 2.2. Signal Processing

On this section, each signal processing method to remove the BW is described. To compare each method's effectiveness, the root-mean-square (RMS) value and standard deviation ( $\sigma$ ) were compared with the RMS value and  $\sigma$  of the original signal to calculate the attenuation level it provided, assuming the only noise contribution is the variation of the BW. The RMS value and  $\sigma$  were calculated with the MATLAB *rms* and *std* functions respectively.

#### 2.2.1. Method 1. Second-Order High-Pass Butterworth Filter

A second-order high-pass butterworth filter was designed with the Filter Designer MATLAB application [6]. The cut frequency was set to 1 Hz. Figure 3 shows the filter's magnitude response.

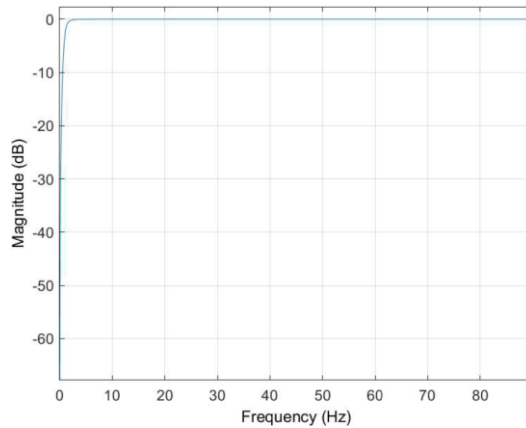

Figure 3. Magnitude response of filter.

#### 2.2.2. Method 2. Spline Interpolation

A trend vector was generated by a spline interpolation using samples from the original recorded signal. These sample points are chosen in the segment between the T and P waves where the ECG is in the isoelectric phase, where the ideal value of the baseline signal should be zero. The points were manually selected and are shown in Figure 4.

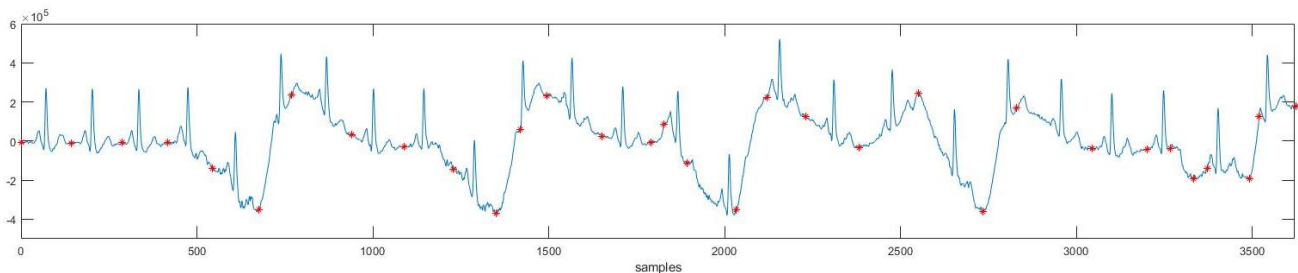
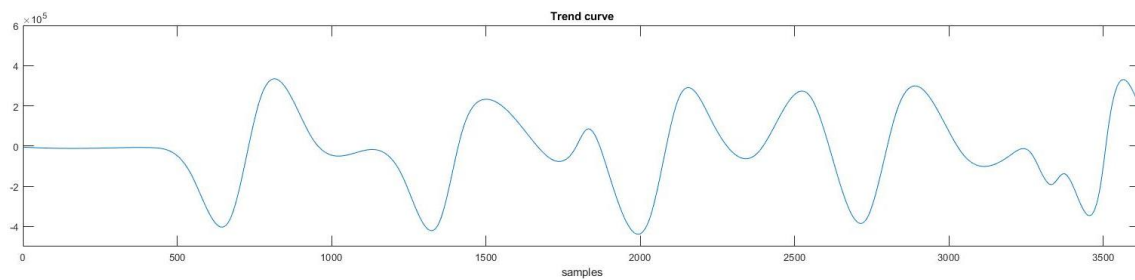

Figure 4. Selected samples of original signal to build trend curve.

Using the MATLAB spline function, the trend curve was generated as shown in Figure 5.



**Figure 5.** Generated trend curve by spline interpolation.

The processed signal was obtained by subtracting the trend curve vector from the original signal.

### 2.2.3. Method 3. Using an ECG Rest Cycle Template

To design this method, it is assumed that once the BW is removed, every ECG wave shape during the recording was equal in the signal. Therefore, an ECG wave during resting position when no BW was present was used as a template to build an expected signal (ES).

The selected ECG wave to be used as template was the first ECG wave in the original signal and is shown in Figure 6, since the signal capture started on a rest position. But it is still a debate what is the best way to construct the template since there are several complete rest cycles before motion artifacts occurs, and it is assumed that during his/her daily activities the user can establish a resting period at will.

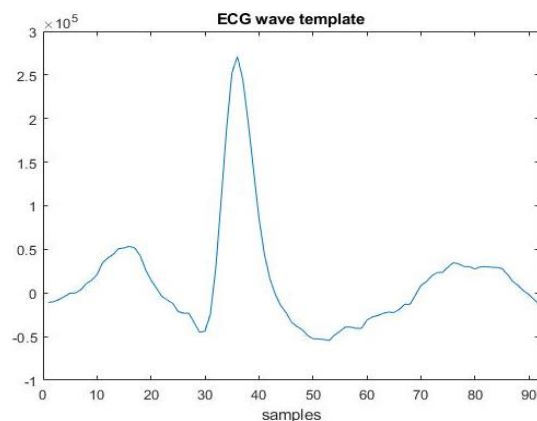

**Figure 6.** ECG rest cycle wave template.

The desired signal was built by placing the template (shown in Figure 6) along a vector in the same positions where every ECG wave in the original signal is present, being centered by the R peak (highest value) of the wave. The R peaks were manually detected now but for future implementation there are several automated algorithms that can achieve the peak detection. Figure 7 shows the result of the expected signal, with template copies moved to the positions of the R peak of the original signal.

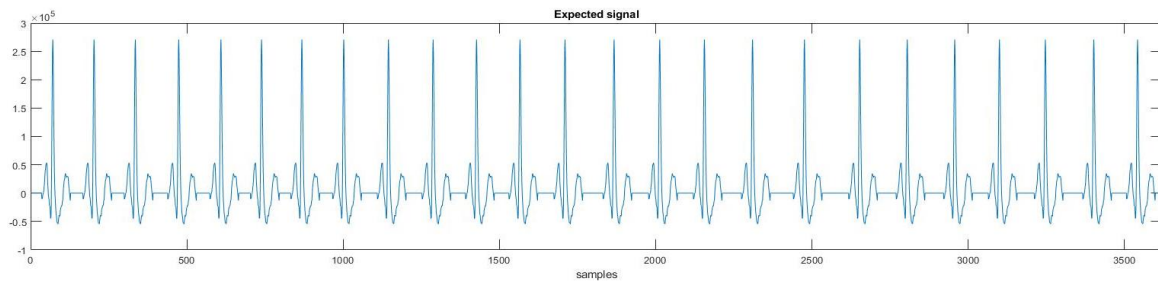

Figure 7. Expected signal.

By subtracting the expected signal from the original signal, the motion artifact was obtained (Figure 8a). A small amount of high frequency noise appears, but after applying a second-order low-pass butterworth filter with a 1Hz cutoff frequency to the motion artifact, a curve that replicates the BW results, as shown in Figure 8b.

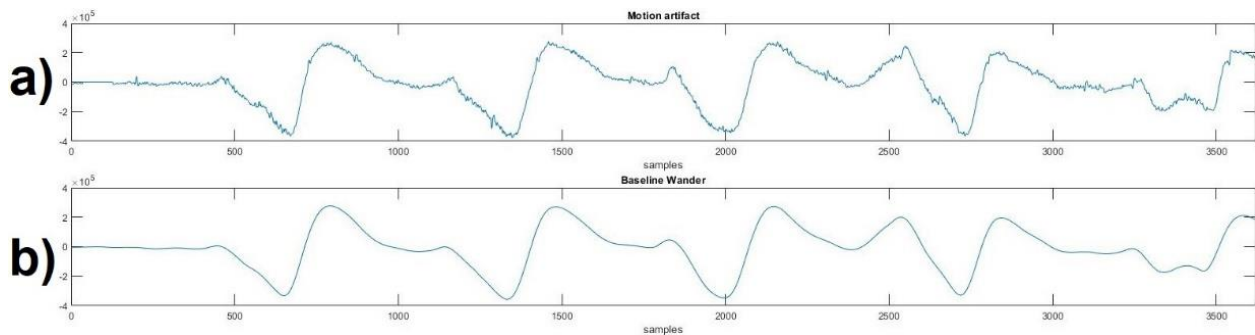

Figure 8. (a) Motion artifact after subtraction of expected signal (template train) to the original signal. (b) Baseline Wander.

The processed clean ECG signal is obtained now by subtracting the curve that replicates the BW (Figure 8b) from the original signal.

### 3. Results and Discussion

Figure 9 shows the resulting signal of each method, as well as the original signal. Visually, the signal that results from method 3 is the less affected by BW. However, the comparison is made using their RMS value and  $\sigma$ , as stated on Section 2.2. Table 1. Shows the numeric results of the comparison.

Table 1. This table shows the comparison between each method described in this work. The RMS value and standard deviation ( $\sigma$ ) of each processed signal are compared with the RMS value and standard deviation ( $\sigma$ ) of the original signal. The attenuation that each method provides is shown.

Method	RMS	$\sigma$	RMS Ratio	$\sigma$ Ratio	RMS Attenuation (dB)	$\sigma$ Attenuation (dB)
Original signal	160,230	160,238	1.00	1.00	0.00	0.00
Method 1	81,722	71,643	0.51	0.45	-2.92	-3.50
Method 2	87,154	84,682	0.54	0.53	-2.64	-2.77
Method 3	59,670	58,629	0.37	0.37	-4.29	-4.37

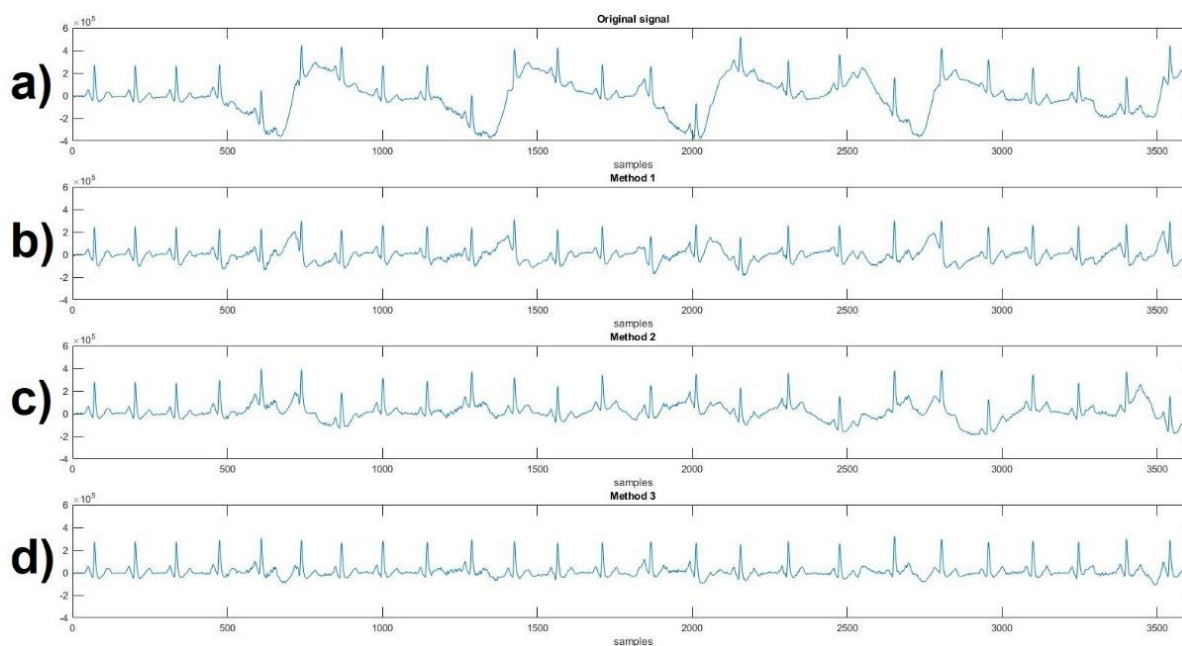

**Figure 9.** Resulting signals comparison with original signal. a) Original Signal. b) Method 1 resulting signal. c) Method 2 resulting signal. d) Method 3 resulting signal.

As observed on Table 1. Using an ECG rest cycle (method 3) as template to remove BW from a noisy ECG signal provides a higher attenuation of the BW than applying a second-order high-pass butterworth filter, as well as it provides a higher attenuation than using a generated trend curve by spline interpolation to remove BW.

A more accurate trend curve could be generated if more points from the original signal are used. However, since the points are limited to sections of isoelectric potential where no ECG waves are present, BW would not be completely removed. Using a second-order butterworth high-pass filter provides a higher attenuation of BW than using spline interpolation.

#### 4. Conclusions

The usage of wearable devices to record an ECG signal from a patient in daily activities can easily corrupt the signal of interest with motion artifacts. However, with adequate post-processing, a smooth and useful ECG signal can be achieved by removing the BW, as the method of ECG rest cycle template presented. This wearable device method required a high-resolution 24-bit ADC and a low gain AD8232 analog input, together with the capability for the patient to set a resting moment. The usage of a QRS peak detector is recommended to automate the build of the expected signal, which is the key to correctly establish the motion artifacts.

**Author Contributions:** Conceptualization and methodology, investigation, writing—review and editing, supervision, project administration, E.A.-C. and M.B.-Z.; software, writing—original draft preparation, visualization, E.A.-C.; validation, M.B.-Z. and D.C.-G.; and final paper review, M.R.-C., and R.L.-A. All authors have read and agreed to the published version of the manuscript.

**Funding:** This research was funded by CONACyT D.C.-G. CVU: 763230 and E.A.-C. CVU: 1055121.

**Institutional Review Board Statement:** Not applicable.

**Informed Consent Statement:** Informed consent was obtained from all subjects involved in the study.

**Data Availability Statement:**

**Acknowledgments:** We thank CONACyT for the scholar fellowship of the author D.C.-G. and E.A.-C.

**Conflicts of Interest:** The authors declare no conflict of interest. The funders had no role in the design of the study; in the collection, analyses, or interpretation of data; in the writing of the manuscript, or in the decision to publish the results.

## References

1. Sörnmo, L.; Laguna, P. Chapter 6—The Electrocardiogram—A Brief Background. In *Biomedical Engineering, Bioelectrical Signal Processing in Cardiac and Neurological Applications*; Academic Press: Cambridge, MA, USA, 2005; pp. 411–452.
2. Armstrong S. Wireless connectivity for health and sports monitoring: a review. *Br. J. Sports Med.* **2007**, *41*, 285–289, doi:10.1136/bjism.2006.030015
3. van Alsté, J.A.; van Eck, W.; Herrmann, O.E. ECG baseline wander reduction using linear phase filters. *Comput. Biomed. Res.* **1986**, *19*, 417–427, doi: 10.1016/0010-4809(86)90037-6.
4. Rangaraj, M. Filtering for Removal of Artifacts. In *Biomedical Signal Analysis: A Case-Study Approach*; IEEE: Manhattan, NY, USA, 2002; pp. 73–176, doi: 10.1109/9780470544204.ch3.
5. Sledzik, J.; Stelengowska, M.; Momot, M. Preserving ST Segment Morphology Using Spline Interpolation for Removal of Wandering Baseline Effect in ECG Signal. In *5th European Conference of the International Federation for Medical and Biological Engineering. IFMBE Proceedings*; Jobbágy, Á., Eds.; Springer: Berlin/Heidelberg, Germany, 2011; Volume 37. Available online: [https://libcon.rec.uabc.mx:4440/10.1007/978-3-642-23508-5\\_121](https://libcon.rec.uabc.mx:4440/10.1007/978-3-642-23508-5_121) (accessed on).
6. Cuevas-González, D.; Bravo-Zanoguera, M.; Altamira-Colado, E.; López-Avitia, R.; García-Vázquez, J.P.; Reyna, M.A. Coping with Motion Artifacts by Analog Front-End ECG Microchips under Variable Digital Resolution and Gain. *Eng. Proc.* **2020**, *2*, 12, <https://doi.org/10.3390/ecsa-7-08247>
7. SparkFun. Single Lead Heart Rate Monitor AD8232. Available online: <https://www.sparkfun.com/products/12650> (accessed on 5 October 2020).
8. Filter Design (MATLAB). 2018. Available online: <https://la.mathworks.com/discovery/filter-design.html> (accessed on 25 October 2020).