

Intelligent Sensing and Control System for Real-Time Graded Load Shedding

Dhanasekar Ravikumar*, Vijayaraja L, Kaushik V N, Anandan R and Guru sharan G M

Department of Electrical and Electronics Engineering, Sri Sairam Institute of Technology, Chennai, Tamilnadu, India; dhanasekar.eee@sairamit.edu.in; vijayaraja.eee@sairamit.edu.in; vnkaushik09@gmail.com; anandanravisankar@gmail.com; gurusharangm@gmail.com

* Correspondence: dhanasekar.eee@sairamit.edu.in; vnkaushik09@gmail.com

† Presented at the The 4th International Electronic Conference on Applied Sciences, place, and date.

Abstract: The power shortage is a common case prevailing in today's power scenario. Load Shedding occurs when the demand power is greater than generation power, then the excessive load is to cut avoid power shortage. Usually, load shedding will make use of complex circuitry and systems along with expensive materials. This necessitates the need for a simple and efficient solution that meets all the requirements. The intelligent system is created with the help of microcontrollers achieving Real-time Load shedding. The power limit in the system is obtained from the utility company. The measured value in the system is obtained from the sensor and the value is compared to the power limit. If it is within the limit, no action is taken. When the limit exceeds the calculated value, the power supply is cut off. Graded Load shedding is achieved through the above-mentioned method. Through this graded load-shedding method, the need for changing the existing infrastructure is removed and the existing system is made useful for more amount of time. As this proposed design uses the simplest of the components and technologies, the financial and technical capital that is required to make this is lower as compared to the existing technologies.

Keywords: Load-Shedding; Intelligent system; IoT; Arduino Mega

1. Introduction

Load shedding is defined as the process of cut-off of power and energy supply to the loads when the demand power exceeds the generating power. Till today, the prevailing load-shedding method is conventional and is not suitable for the existing times. so various attempts were made to make the Load shedding feasible with the advanced theories [1]. The near future requires the drive towards green energy [2] referring to drawing energy from renewable sources of energy [3, 4], which is designed based on the system supplied by non-renewable sources of energy [5], tuning the infrastructure to meet the new normal becomes time and capital consuming process. Although many changes are being introduced in the existing load shedding methods [6,7,8]. The proposed device is designed to make the current system equipped for the future with minimal changes. The addition of this device to the existing energy meter will be sufficient for the purpose. Focusing on the energy pattern and the energy availability [9], the device is designed to alert the users and set the energy values to the defined levels to prevent a complete catastrophe in the energy system and to reduce the use of energy.

The proposed system can also be used in the perspective of load detection and sensing. From the perspective of the energy provider or the utility company, the proposed system could be used in the face of catastrophe [10] and during the circumstances such as the European nations and particularly the United Kingdom faced recently. From the perspective of customers, the proposed system could be of great use. To exercise certain tax benefits, the limit must be maintained. When the limit is exceeded, the chance to avail of

Citation: To be added by editorial staff during production.

Academic Editor: Firstname Last-name

Published: date



Copyright: © 2023 by the authors. Submitted for possible open access publication under the terms and conditions of the Creative Commons Attribution (CC BY) license (<https://creativecommons.org/licenses/by/4.0/>).

that certain tax benefit disappears ends up making the consumer spend more than planned or anticipated. This will require more amount of capital expenditure from the consumer’s perspective. With appropriate warnings and intimation of messages to the consumer, the consumers are made aware of the usage which ultimately helps them save money on the energy. There are many ways Load Shedding such as, Under Voltage Load Shedding (UVLS) [11] and Under Frequency Load Shedding (UFLS) [12].

2. Proposed system of Load shedding

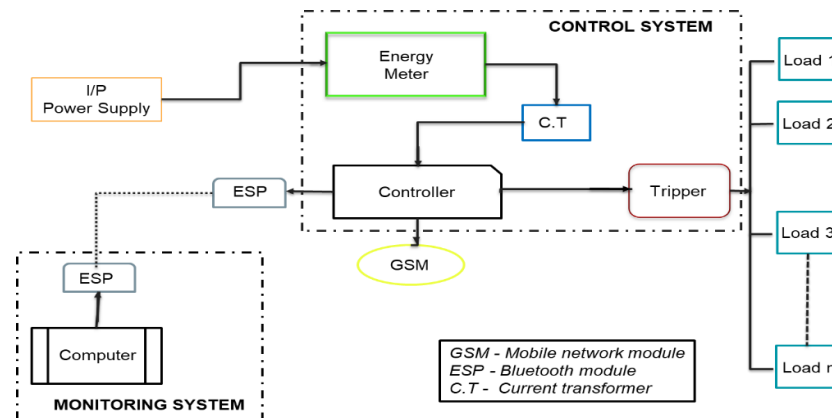

Figure 1. Block diagram of the proposed design.

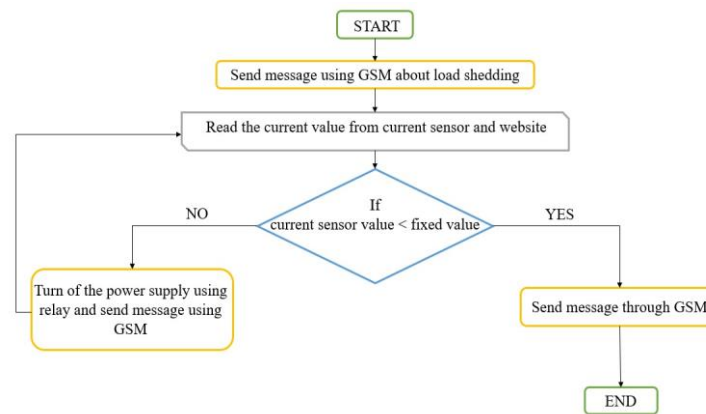

Figure 2. Flow diagram of the proposed design.

Figure 1 and Figure 2 shows the block diagram and flow diagram of the proposed system. The input power supply is provided from the main power supply of 230V, 5A, 50Hz AC supply. The Monitoring system refers to the utility company which specifies the limit of the power to be used during the time of load shedding. This is calculated using the observed data on the usage of energy and the energy available at a given point in time. This is a combined unit and the ESP in this is used for the transmission of signals from the utility company to the individual unit meters in each nodal center. The control system comprises various components such as a Controller, Energy meter, Current Transformer, and tripper. The controller is the key component in the designed device. For this purpose, an arduino Mega microcontroller is used. An energy meter tracks the usage of energy. This current transformer is used to check the amount of current passing through and is used for Current Detection. A tripper is provided to turn off when the current exceeds the set limit. The limit is set by the utility company and the checking of loads consuming more

value than the set limit is checked by the controller. This ESP will receive the data set by the utility company and provide this data to the controller. The controller will do all the necessary actions. The GSM provides communication between the consumers and the device. The status, alerts, and the information to be known by the users are passed to the consumers using the GSM module.

3. Simulation work for the proposed device

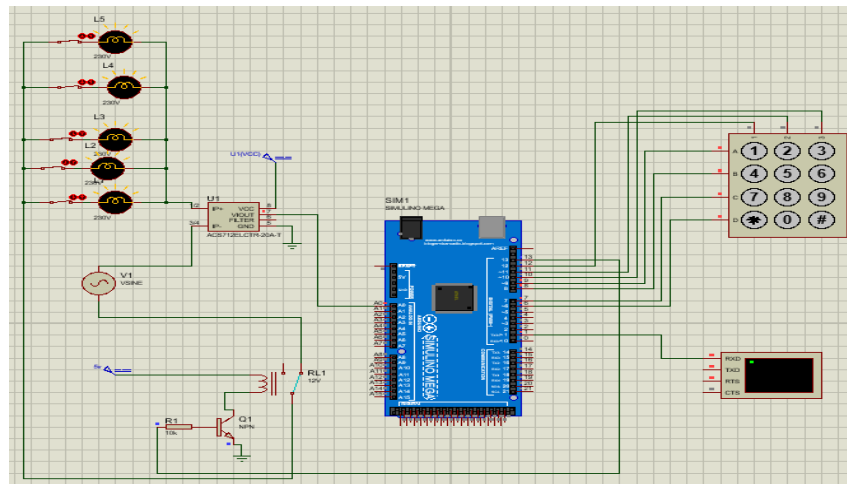

Figure 3. simulation circuit of the proposed design.

Figure 3 depicts the simulation circuit of the proposed design. This shows the predominant components that are present in the device which includes Load are lamp 1, lamp 2, lamp 3, lamp 4, lamp 5, current sensor, relay, a keypad, transistor, Arduino, and a display apparatus. The Simulation diagram depicts the working of the proposed device and confirms the feasibility of the proposed design. In this simulation diagram, the keypad device is used to simulate the set value determined by the utility company. The display device depicts the information-receiving device of the customer. The working of the simulated circuit is simple, which is explained as follows: The power supply is provided to the loads. A current sensor is provided which will measure the amount of current passing from the source of energy to the loads. The current sensor provides input to the microcontroller. Now the keypad is used to simulate the utility company. A value is set by the simulation tester. This value is provided to the microcontroller. The controller compares both inputs and provides an output. Two cases are used to describe the usage of the proposed design, described in Figure 4, and Figure 5.

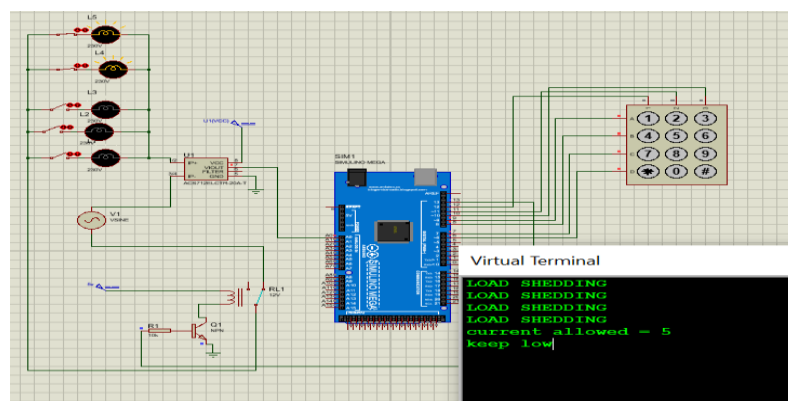

Figure 4. During load shedding, when power consumption is within the limit.

One of the cases is Figure 3 and in the diagram, the current conducts without an interruption. That is, the input provided by the current sensor is within the set value from the utility company. So, there is no interruption in the power supply provided. Here lamp1 and lamp2 are within the limit so the power will not get interrupted. This simulation is run for a different set of values. The second case is experimented with in Figure 4, and in the second case where the load shedding occurs. the load exceeds the supply power. Meaning, that the value from the current sensor is more than the value set by the utility company or in this case, from the keypad. So, this actuates the tripper. This results in the cut-off power supply. Here lamp 1, lamp 2, and lamp 3 are ON so the power consumption becomes high so the power gets interrupted. The appropriate message is displayed on the screen. The amount of current utilized within the limit for the uninterrupted power supply. Table 1 shows the component description of simulation.

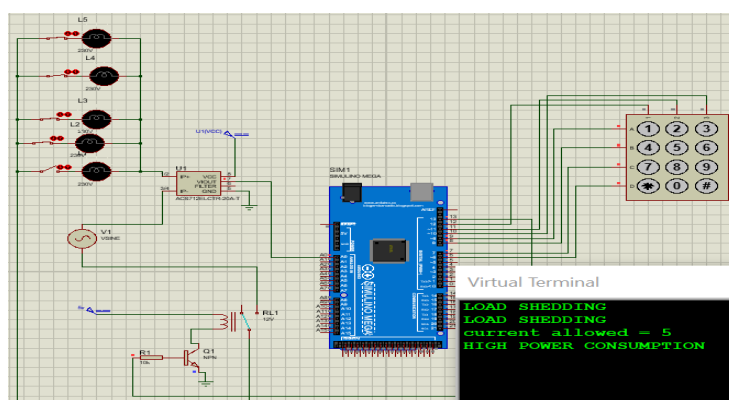

Figure 5. During load shedding, when the power consumption exceeds the limit.

Table 1. Component description of simulation.

Name of the component	Description
Arduino Mega	--
Keypad 4×4	-
Lamp L1, L2, L3, L4, L5	1A, 2A, 3A, 4A, 5A
Current Sensor (ACS 712)	0-30A, 5V
Relay	16A, 5V

3.1. Circuit diagram

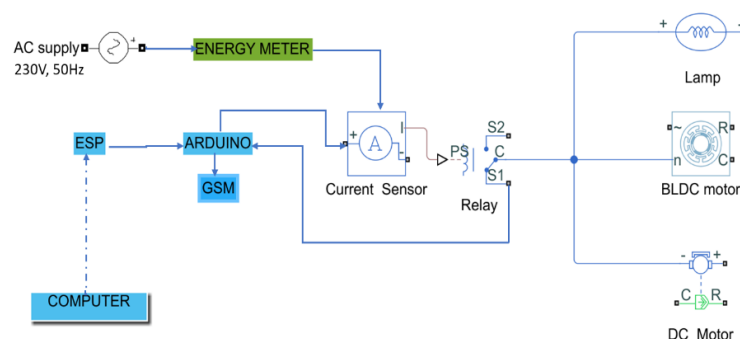

Figure 6. Circuit diagram of the proposed design.

Figure 6 shows the energy meter powering the current sensor, which reads the system current. The utility company's computer determines the current flow and the ESP model sends the current value. Further, the Arduino board connects the ESP model which is supported by Bluetooth and Wi-Fi. The Arduino board reads the current sensor and ESP model input. The controller is used for processing as programmed by the utility

company and it activates the tripper. Also sends a GSM message to the consumer indicating load shedding. The controller cuts electricity and engages the tripper. The consumer can analyze the power usage and consumption may be customized further.

4. Hardware setup for the proposed system

The hardware of the proposed design is shown in Figure 7 which consists of a current sensor, an energy meter, the GSM model, a tripper, a controller, and an input power supply. The energy meter reads the amount of energy that is being passed at the moment. The current sensor is connected along the power line and is used to read the amount of current that is passing through at regular time intervals. The value from the current sensor is passed to the controller for observation of usage by the consumer. The amount of power for load shedding that has to be passed through the power line will be specified by the utility company. The controller in the back-end calculates the amount of current by using the wattage given by the utility company for setting a maximum limit for the load side. During the time of load shedding, the controller operates by comparing the input from the current sensor and the value from the utility company. The controller decides whether to activate the relay and cut off the power supply or to continue with the conduction undisturbed. When the value of the current from the current sensor exceeds the current value calculated from the wattage given by the utility company, the relay is activated by the controller and the load shedding happens. when the current value is within the limits the relay will not be activated. By Load shedding, the unnecessary appliances are asked to be turned off and to be used within the limits. This message is given from the GSM to the respective consumers of the unit enabling information communication on load shedding. Figure 8 (a) and Figure 8 (b) shows the power consumption within and exceed the limit.

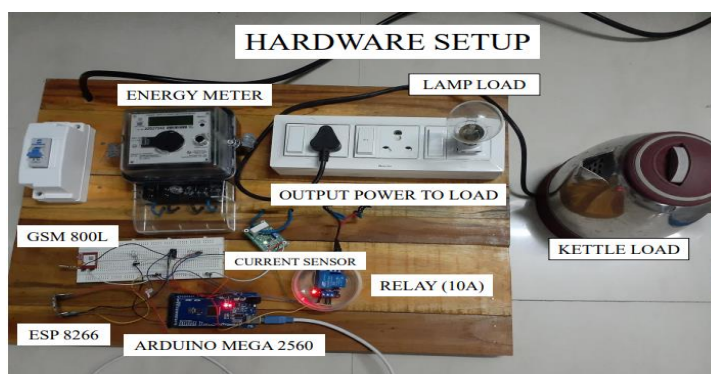

Figure 7. Hardware Setup of the proposed design.

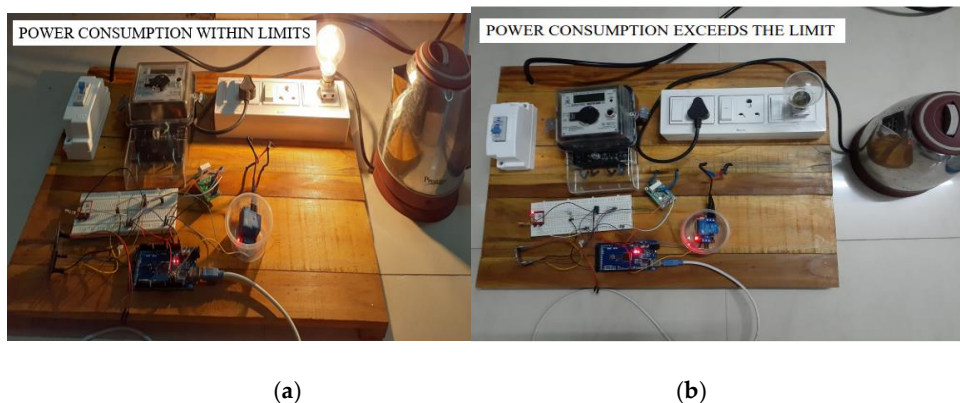

Figure 8. (a) Power Consumption within the Limit; (b) Power consumption exceeds the limit

5. Conclusion

The proposed system of load shedding is ultimately created to adapt to the existing distribution network and provide an easy interaction method for the utility company and the consumer to communicate in a better manner to avoid the collapsing of the system and to protect the existing system. The proposed system just aims to be the bearer for the adaptation of existing distribution network to be adaptable for the requirements of future. The foundation that the proposed system lays on load shedding, is that it is time tested, and it is a long-standing practice for effective safety and energy-saving concerns. The proposed system supersedes the existing load shedding with the feature of providing the consumer with a choice before their power supply gets cut off. The consumer is provided with the option to receive the power supply or to avoid it. The proposed device attempts to make load shedding the simplest and hassle free way, by providing an easy means to be added to the existing system of transmission and distribution. The proposed system focuses on the Load Shedding to be done in homes and residential places.

Author Contributions: Conceptualization, Kaushik V N and Dhanasekar Ravikumar.; methodology, Guru sharan G M and Vijayaraja L; software, Anandan R.; validation, All the Authors.; investigation, All the Authors.; writing—original draft preparation, All the Authors.; writing—review and editing, supervision, Dhanasekar Ravikumar, and Vijayaraja L.

Funding: This research received no external funding

Institutional Review Board Statement: Not applicable

Informed Consent Statement: Not applicable

Data Availability Statement: Not applicable

Conflicts of Interest: The authors declare no conflict of interest

References

1. Kai Hou; Puting Tang; Zeyu Liu; Hongjie Jia; Kai Yuan; Chongbo Sun; Yi Song. A fast optimal load shedding method for power system reliability assessment based on shadow price theory. *Energy Reports*, **2022**, Volume 8, Supplement 1, pages 352-360.
2. Moji, L.P.; Hohne, P.A.; Kusakana, K.; Numbi, B.P. Optimal operation of a hybrid multisource energy system considering grid load shedding. *Energy Reports*, **2022**, Volume 8, Supplement 15, pages 151-161.
3. Lin Ye; Jingliao Sun; Taibin Zhou; Jing Zhang; Weizhen Sun; Honglei Xi. A practical under-voltage load shedding strategy for regional power grid considering multiple operating modes. *Energy Reports*, **2021**, Volume 7, Supplement 1, pages 175-182.
4. Ismi Rosyiana Fitri.; Jung-Su Kim. Economic Dispatch Problem using Load Shedding: Centralized Solution, *IFAC-Papers OnLine*, **2019**, Volume 52, Issue 4, pages 40-44.
5. Ardiaty Arief; ZhaoYang Dong; Muhammad Bachtiar Nappu; Marcus Gallagher. Under voltage load shedding in power systems with wind turbine-driven doubly fed induction generators. *Electric Power Systems Research*, **2013**, Volume 96, pages 91-100.
6. Tamilselvan, V.; Jayabarathi, T. A hybrid method for optimal load shedding and improving voltage stability. *Ain Shams Engineering Journal*, **2016**, Volume 7, Issue 1, pages 223-232.
7. Yilin Chen; Siyang Liao; Jian Xu. Emergency load-shedding optimization control method based reinforcement learning assistance. *Energy Reports*, **2022**, Volume 8, Supplement 5, pages 1051-1061.
8. Arifur Kabir, Md.; Hasib Chowdhury, A.; Nahid-Al- Masood. A dynamic-adaptive load shedding methodology to improve frequency resilience of power systems. *International Journal of Electrical Power & Energy Systems*, **2020**, Volume 122, pp.106169.
9. José Ignacio Sarasúa; Guillermo Martínez-Lucas; Juan Ignacio Pérez-Díaz; Daniel Fernández-Muñoz. Alternative operating modes to reduce the load shedding in the power system of El Hierro Island. *International Journal of Electrical Power & Energy Systems*, **2021**, Volume 128, pp.106755.
10. Rabby, Md Insiat Islam. Current Energy Crisis and Energy Insecurity Situation In Bangladesh Available at SSRN: **August 8, 2022**.
11. Ardiaty Arief, Muhammad Bachtiar Nappu, Zhao Yang Dong, Dynamic under-voltage load shedding scheme considering composite load model, *Electric Power Systems Research*, Volume 202, 107598, ISSN 0378-7796. (2022)
12. Maresch, K.; Marchesan, G.; Cardoso, G. A logistic regression approach for improved safety of the under-frequency load shedding scheme owing to feeder machine inertia. *Electric Power Systems Research*, **2023**, Volume 218, pp. 109189.

Disclaimer/Publisher's Note: The statements, opinions and data contained in all publications are solely those of the individual author(s) and contributor(s) and not of MDPI and/or the editor(s). MDPI and/or the editor(s) disclaim responsibility for any injury to people or property resulting from any ideas, methods, instructions or products referred to in the content.