

Selection of bias correction methods to assess the impact of climate change on flood frequency curves

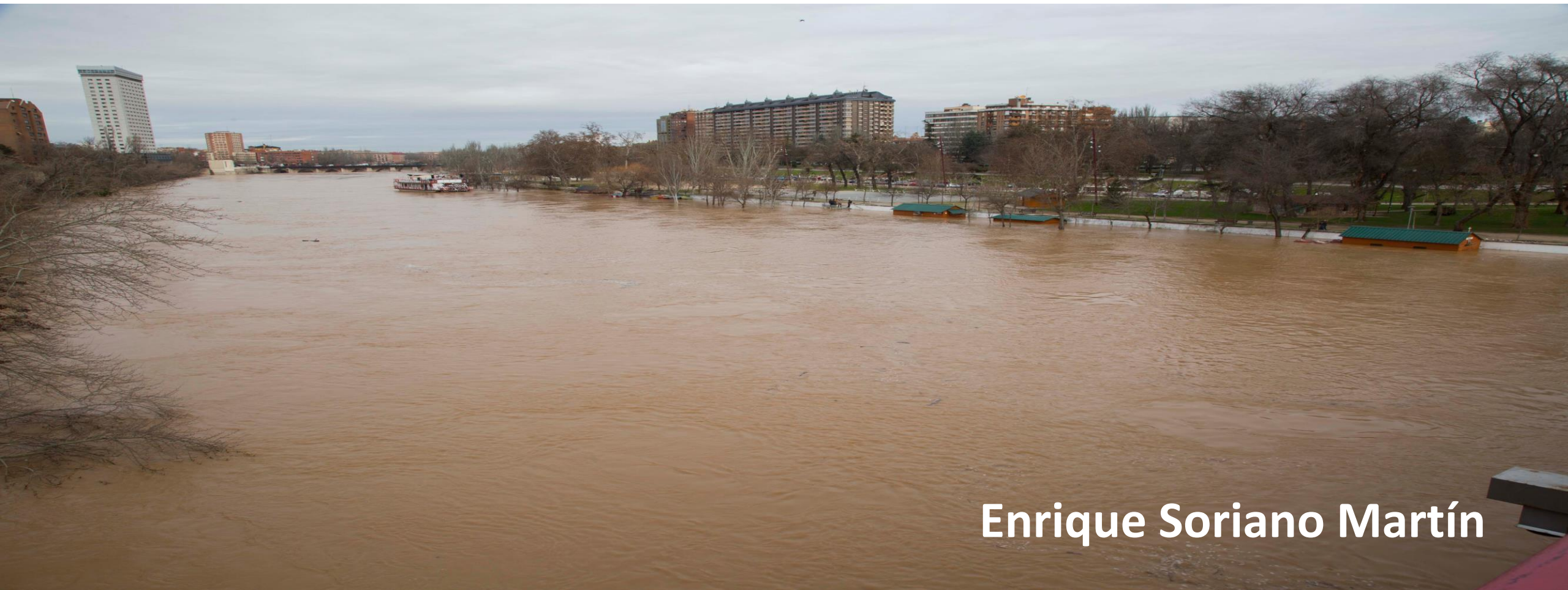

Enrique Soriano Martín

- In Spain, there are two sources of climate projections under climate change supplied by AEMET ('Agencia Española de Meteorología', in Spanish) and CORDEX.
- Garijo et al. (2018) found that AEMET projections do not characterise adequately extreme events. Consequently, in this study climate projections supplied by EURO-CORDEX are used.
- Temperature and precipitation time series are the input data of the HBV model, calibrated with the methodology proposed by Garijo and Mediero (2018).
- Bias correction will be applied to both temperature and precipitation time series.



- The four catchments selected are located in the Douro river basin, in the northwestern part of Spain.
- Flow data collected by the Centre for Hydrographic studies of CEDEX.
- Time series of daily observations of rainfall and temperature were supplied by the AEMET.
- Climate change projections provided by 12 regional climate models of the EURO-CORDEX programme have been used.

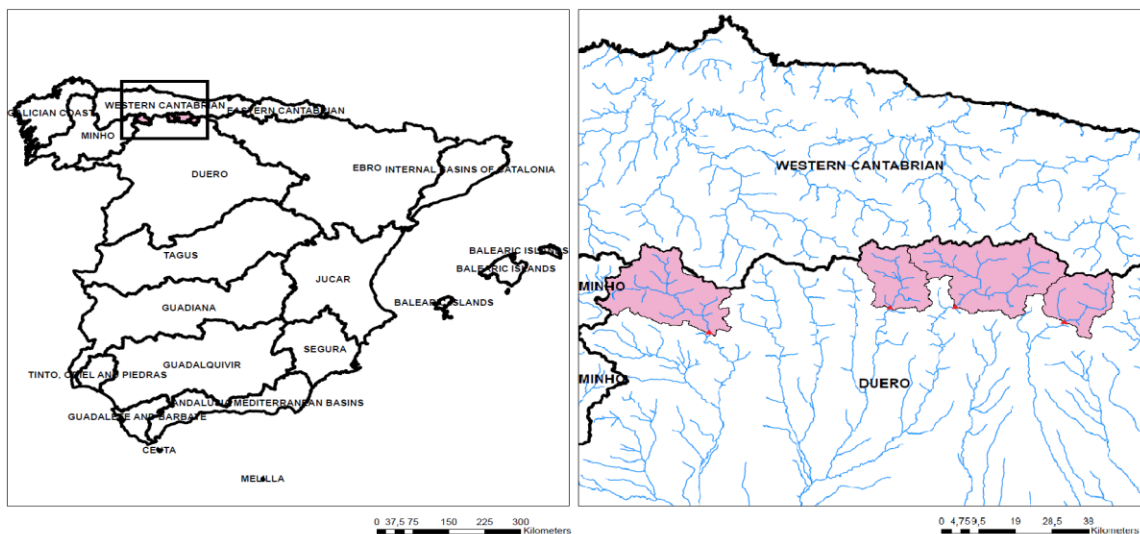

Acronym	GCM	RCM
ICH-CCL	ICHEC-EC-EARTH	CCLM4-8-17
MPI-CCL	MPI-ESM-LR	CCLM4-8-17
MOH-RAC	MOHC-HadGEM2-ES	RACMO22E
CNR-CCL	CNRM-CM5	CCLM4-8-17
ICH-RAC	ICHEC-EC-EARTH	RACMO22E
MOH-CCL	MOHC-HadGEM2-ES	CCLM4-8-17
IPS-WRF	IPSL-CM5A-MR	WRF331F
IPS-RCA	IPSL-CM5A-MR	RCA4
MOH-RCA	MOHC-HadGEM2-ES	RCA4
ICH-RCA	ICHEC-EC-EARTH	RCA4
CNR-RCA	CNRM-CM5	RCA4
MPI-RCA	MPI-ESM-LR	RCA4

- The flood response in the four catchments has been modelled with the HBV rainfall-runoff model (Seibert and Vis, 2012).
- Precipitation time series have been corrected by using the quantile mapping, lineal and second-degree polynomial techniques.
- Temperature time series were corrected by using the mean error in each month.
- Annual maximum flood and precipitation quantiles have been estimated by using the Generalized Extreme Value (GEV) distribution with the L-moment method.
- The best bias correction method has been identified, correcting the time series in the future period under climate change provided by EURO-CORDEX.
- Delta changes in flood quantiles have been calculated in three time periods: 2011-2041, 2041-2071, 2071-2100

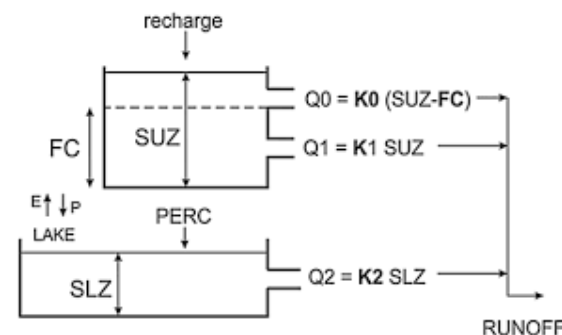
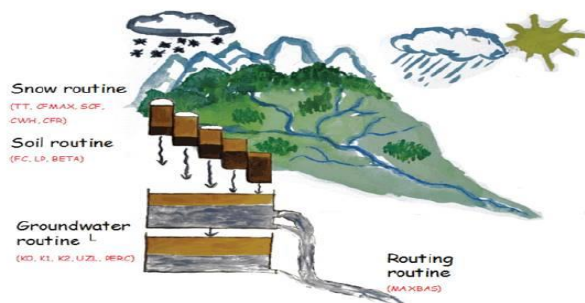

Bias Correction

- Temperature and precipitations time series supplied by climate models in the control period presents a significant difference compared to observed time series in the same period.

Temperature

- Monthly mean temperatures supplied by climate models are significant lower than observations.
- The difference between monthly temperatures supplied by each climate model and observations has been added to the temperature time series in each month to correct the bias.

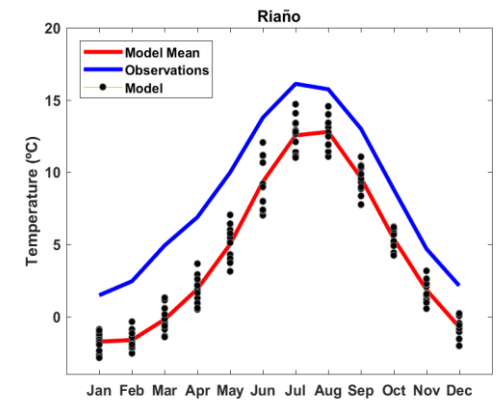
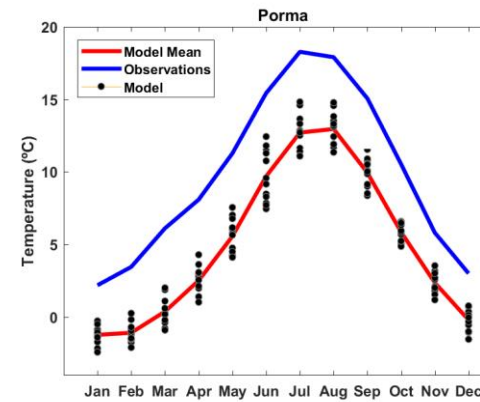
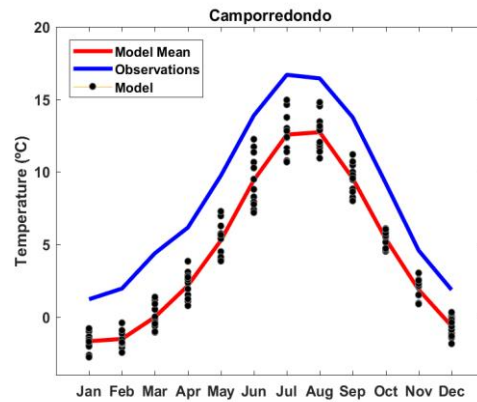
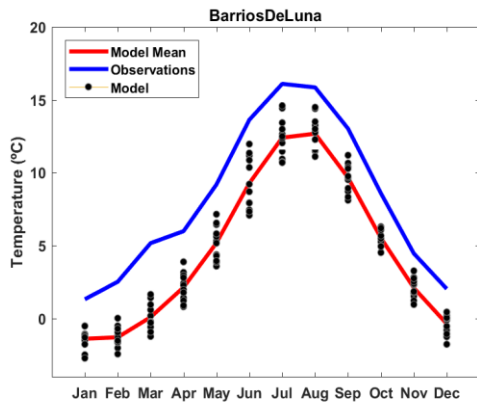

Precipitation

- In the Barrios de Luna catchment, climate models supply larger extreme precipitation than observations. However, in the other three catchments, climate models supply lower precipitations.
- Results obtained after correcting bias by the lineal and polynomial techniques show smaller errors than in the case of raw precipitation data.
- The best bias correction technique is polynomial correction.

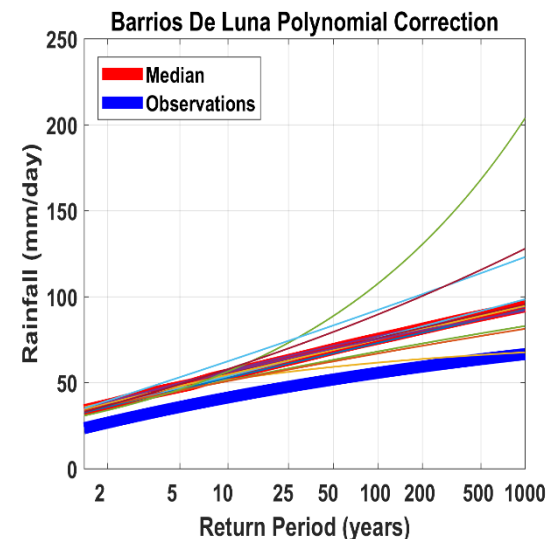
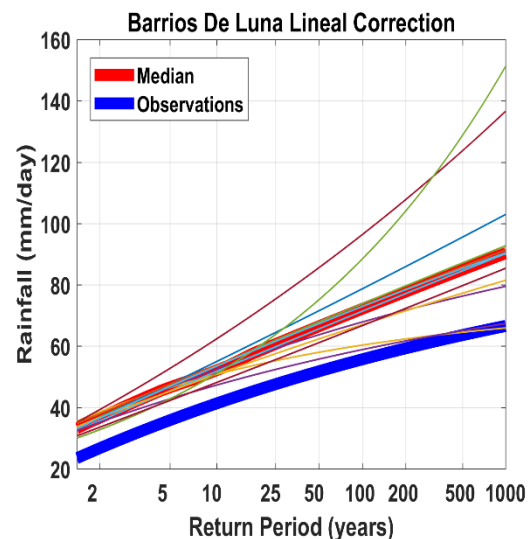
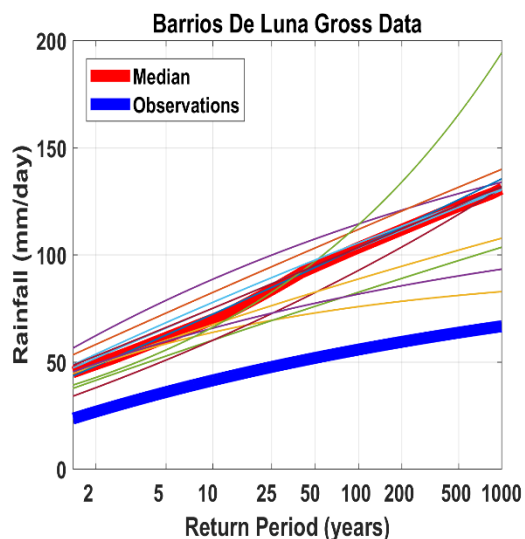

Precipitation

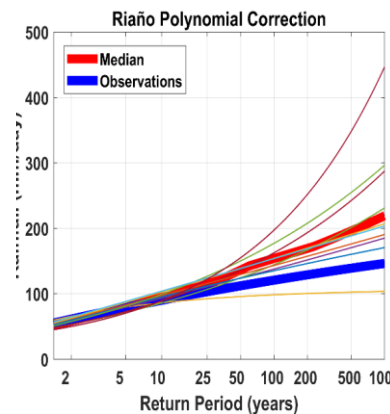
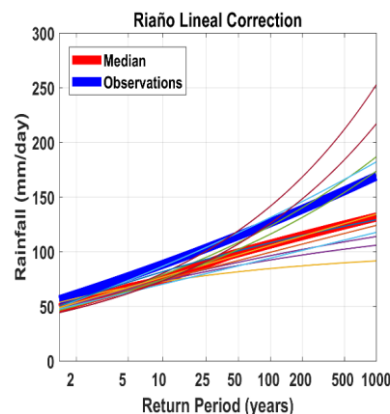
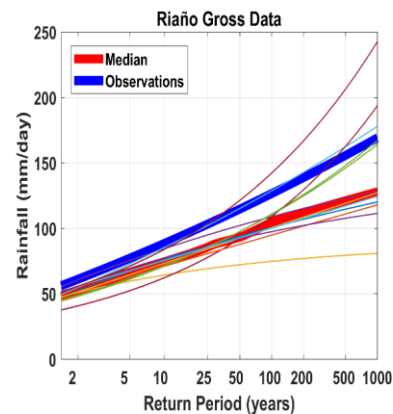
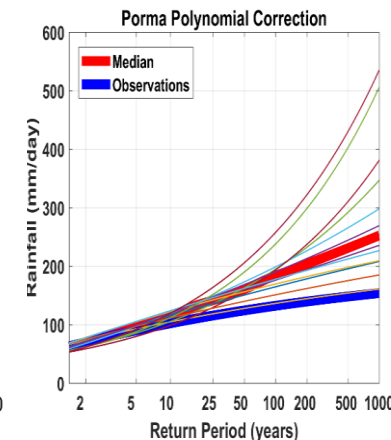
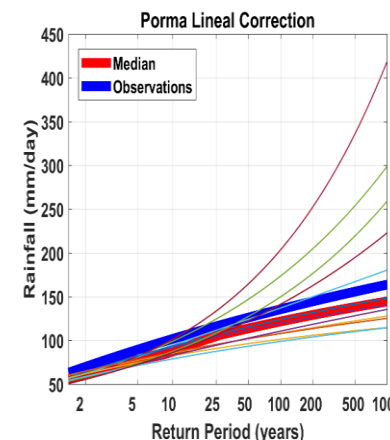
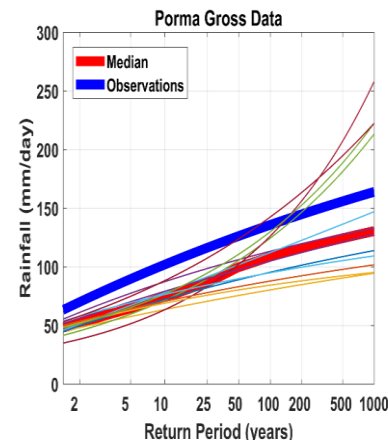
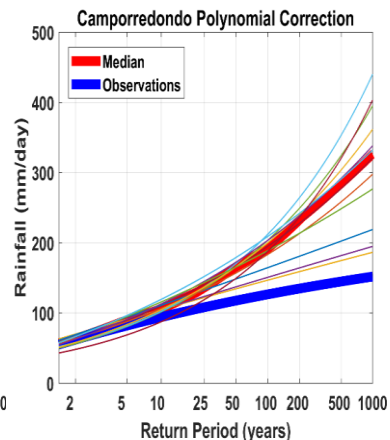
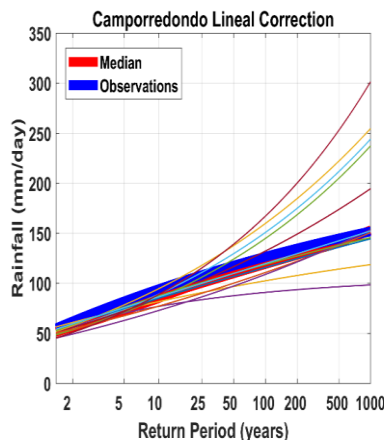
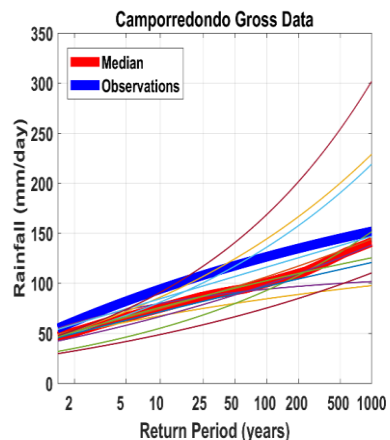

Flood frequency curves in the control period

- The best bias corrections technique will be identified in terms of smaller errors with the flood frequency curve estimated with observations.
- The higher return periods have been considered due to its importance in dam design.
- In general, the smaller are obtained with the polynomial bias correction technique.

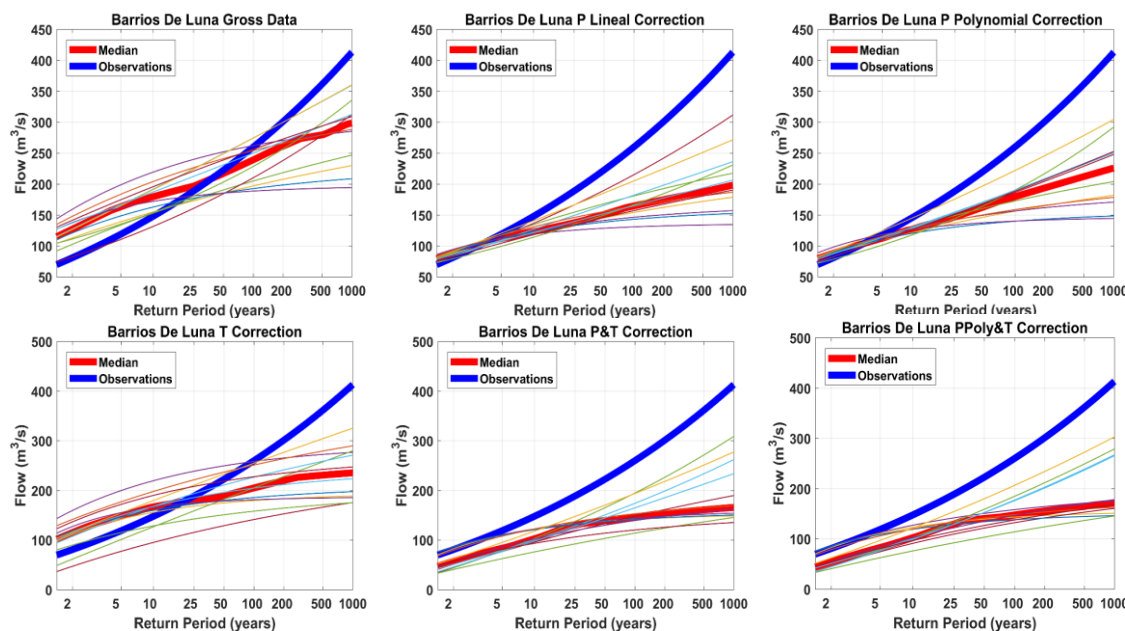

Flood frequency curves in the control period

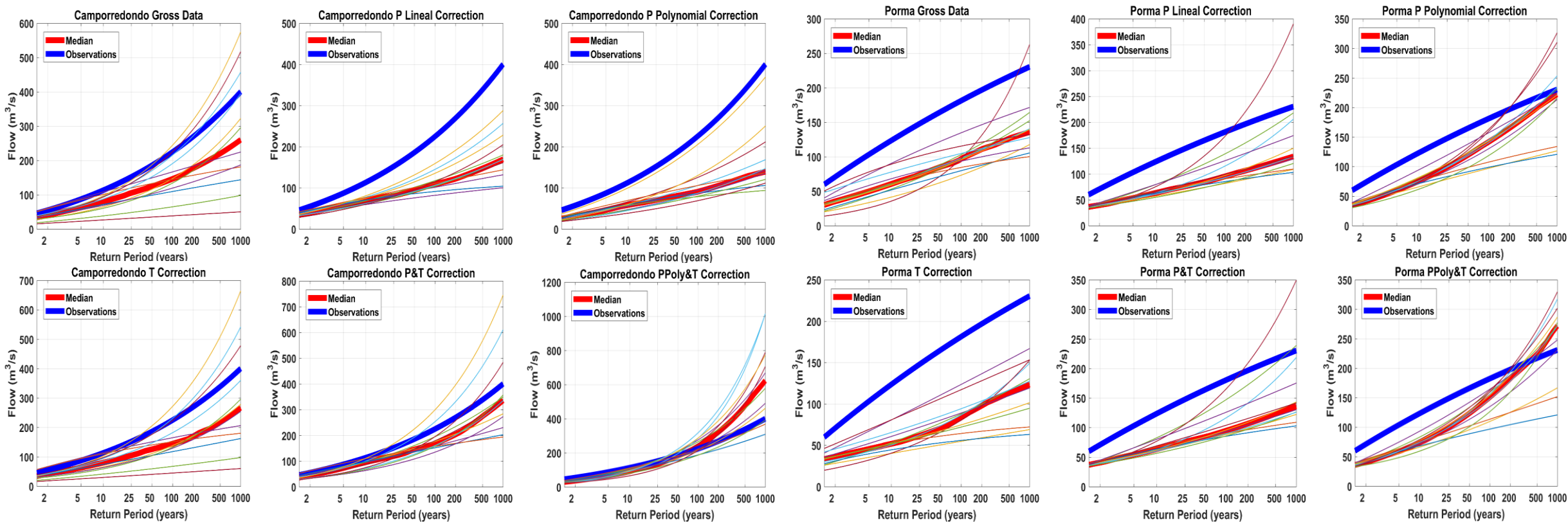

Flood frequency curves in the control period

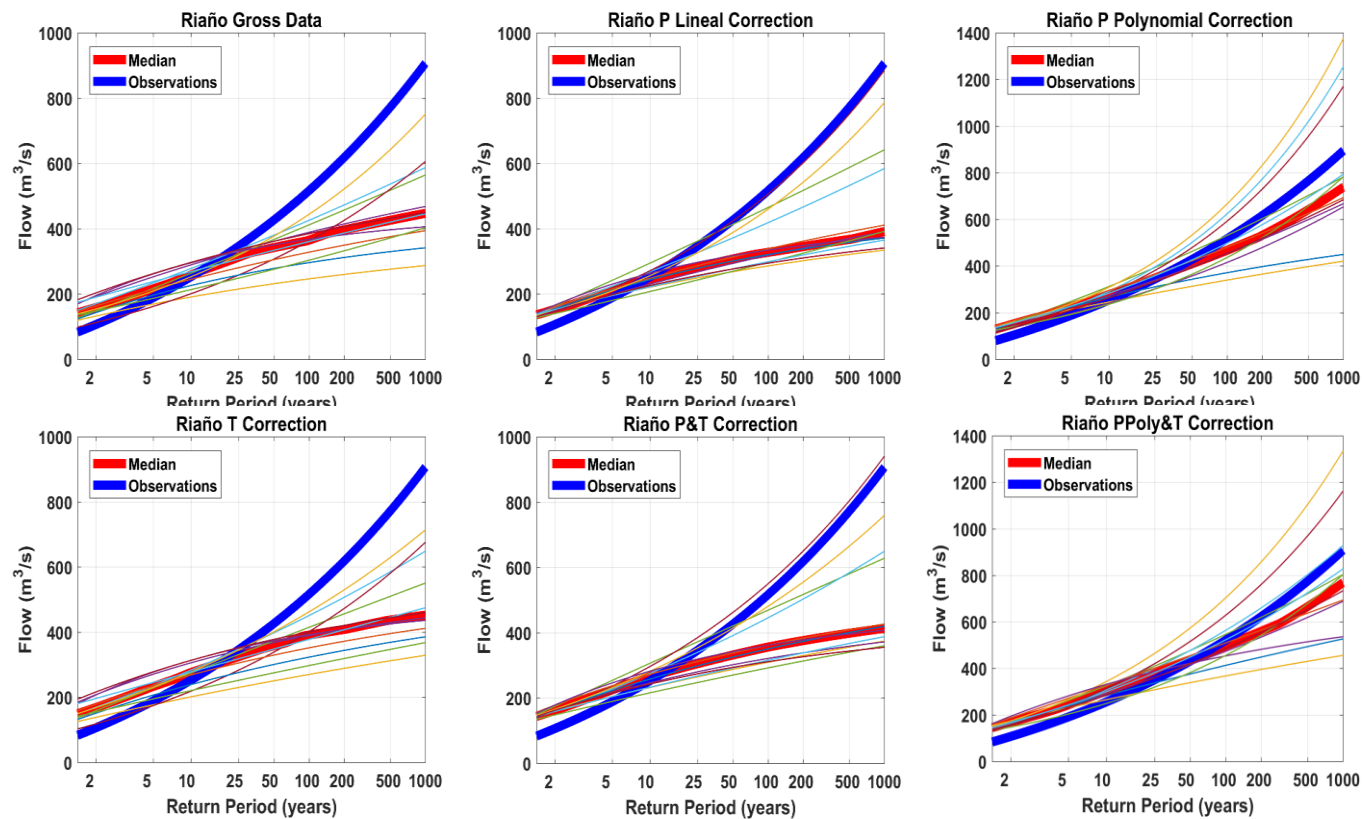

Flood frequency curves in the future period

- Finally, precipitation and temperature projections in the future (2011-2100) were corrected with the best bias correction techniques identified in the previous step.
- Simulations with the HBV model shows that in general flood frequency curves decrease in the future, though an increase can be seen in some cases.

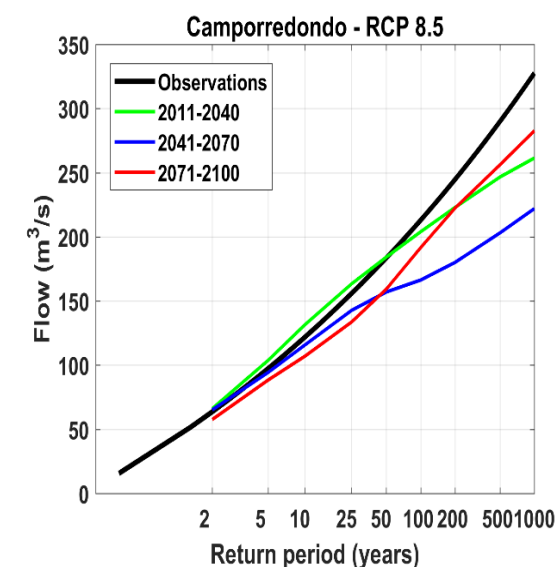
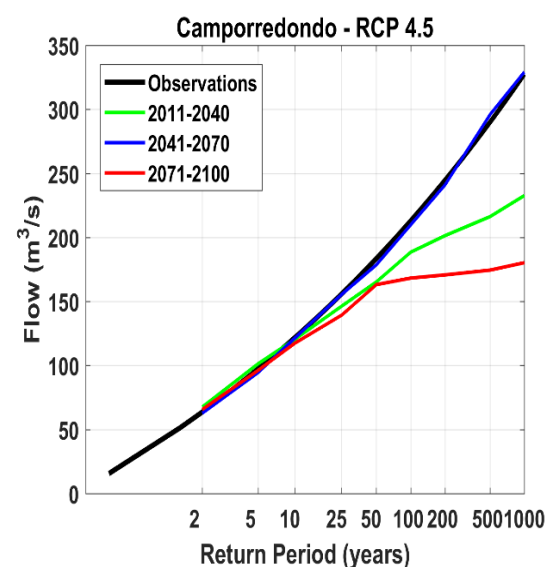
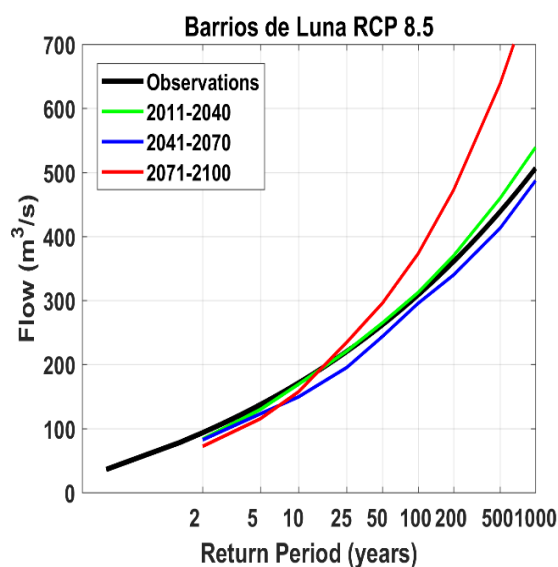
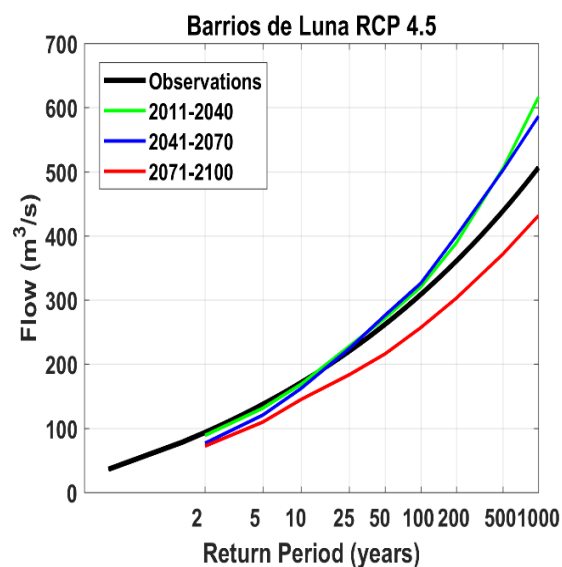

Flood frequency curves in the future period

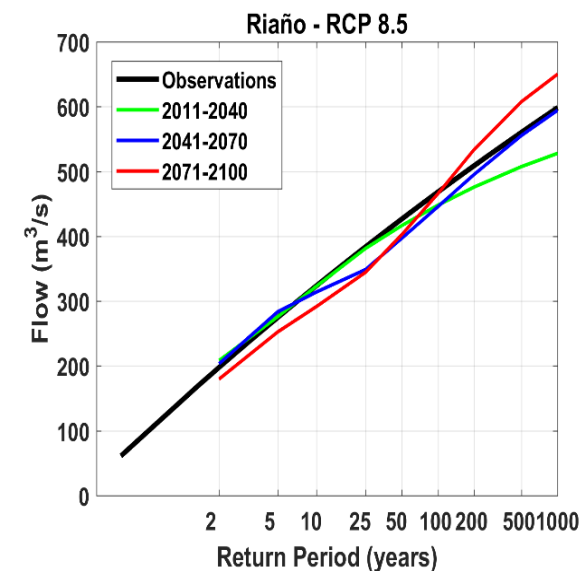
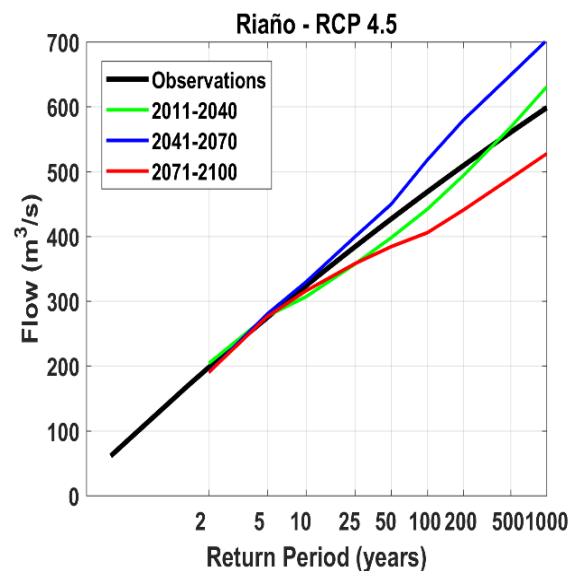
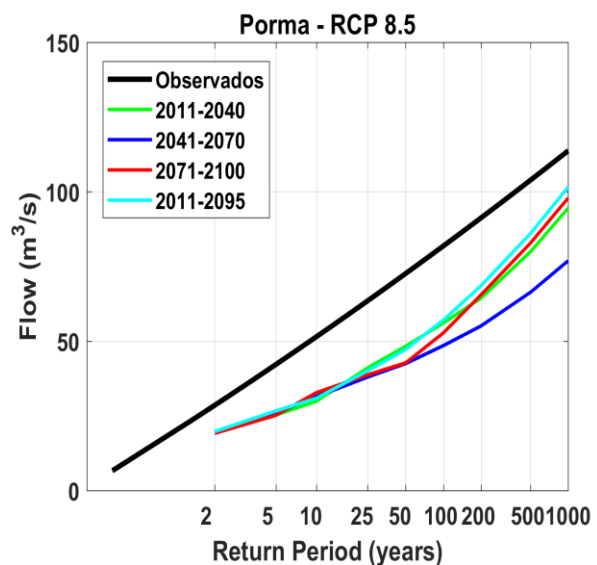
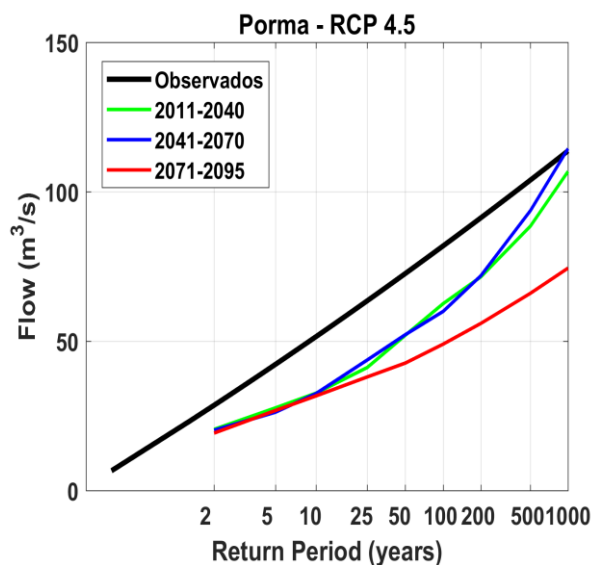

INTRODUCTION

STUDY AREA AND DATA

METHODOLOGY

RESULTS

CONCLUSIONS

- Temperature time series supplied by climate models in the control period are significantly lower than observed data.
- The bias correction of precipitation time series is more important than the temperature correction, affecting flow results.
- The best bias corrections techniques are precipitation polynomial correction and temperature monthly mean correction simultaneously.
- Simulations with the HBV model in the future period under climate change show a general reduction in flood quantiles, smoothing increases in precipitation quantiles. In the control period, when precipitation quantiles in the climate models are larger than observations, flood quantiles are similar to observations.
- In general, the period 2071-2100 presents the smallest reductions and in some cases the larger increases.

THANK YOU FOR YOUR ATTENTION



Contact

*GI de Hidroinformática y Gestión del Agua
ETSI Caminos, Canales y Puertos
Enrique Soriano
e.soriano@upm.es*