

[F001]

Supramolecular host-guest complexes

between coumarin 460 and cyclodextrins: a matter of size

Mercedes Novo, Jorge Bordello, Daniel Granadero, Sonia Freire and Wajih Al-Soufi

Dpto. Química Física, Facultade de Ciencias,
Universidade de Santiago de Compostela, E-27002 Lugo, Spain.

Abstract: The role of the host size on stoichiometry, structure and strength of supramolecular association between a fluorescent probe, coumarin 460 (C460), and the three natural cyclodextrins (CDs) with increasing cavity sizes (α , β and γ -cyclodextrin) is analyzed, using fluorescence spectroscopy. The variations of the fluorescence emission spectra of C460 with CD concentration can be explained with a 1:1 complexation equilibrium model for α -CD and β -CD, but also a 1:2 complex has to be included in the case of γ -CD. Nevertheless, the photophysical properties and the stability of the complexes do not correlate in a simple way with the cavity size. For instance, the association between C460 and β -CD, which is the CD with medium cavity size, is much stronger than with the other CDs but it does not provoke fluorescence enhancement as in those cases. Detailed analysis of fluorescence quantum yields and fluorescence lifetimes of the complexes help us to propose an explanation for this unexpected behaviour. This is the formation of two types of 1:1 complexes with β -CD and γ -CD which differ in the side groups of C460 which are included in the CD cavity and how much effect this has on the photoinduced charge-transfer processes in the coumarins. This system is a nice example how subtle variations in the host-cavity size can induce big structural changes in the supramolecular complexes.

INTRODUCTION: Coumarin 460

- ✓ Aminocoumarins are natural fluorescence probes, some of them biologically active as analgesics, anticoagulants, etc.
- ✓ They are mainly used in cosmetics and in the food industry because of their ability to bind to proteins.
- ✓ Some aminocoumarins undergo charge transfer processes in the excited state that make their fluorescence highly sensitive to the environment [1].

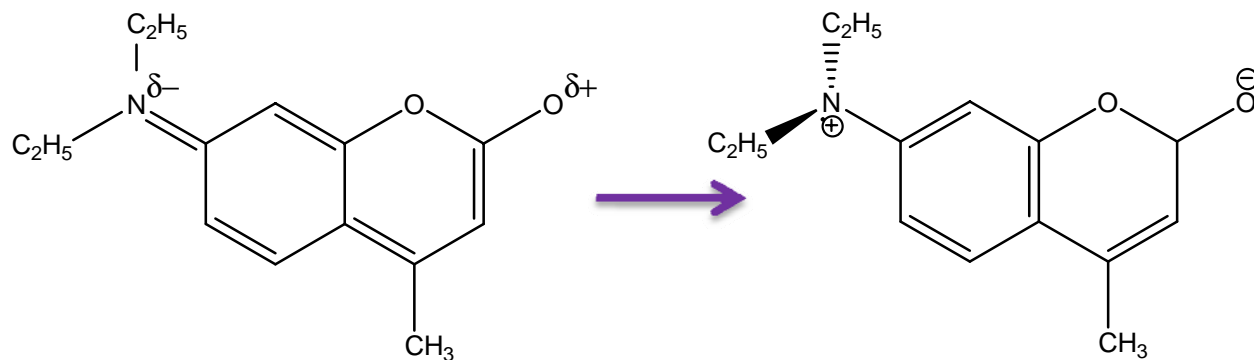

ICT state

- ✓ Non polar media.
- ✓ Strong fluorescence.
- ✓ Emission at shorter wavelengths.

TICT state

- ✓ Polar media.
- ✓ Weak fluorescence.
- ✓ Emission at longer wavelengths.

INTRODUCTION: Cyclodextrins

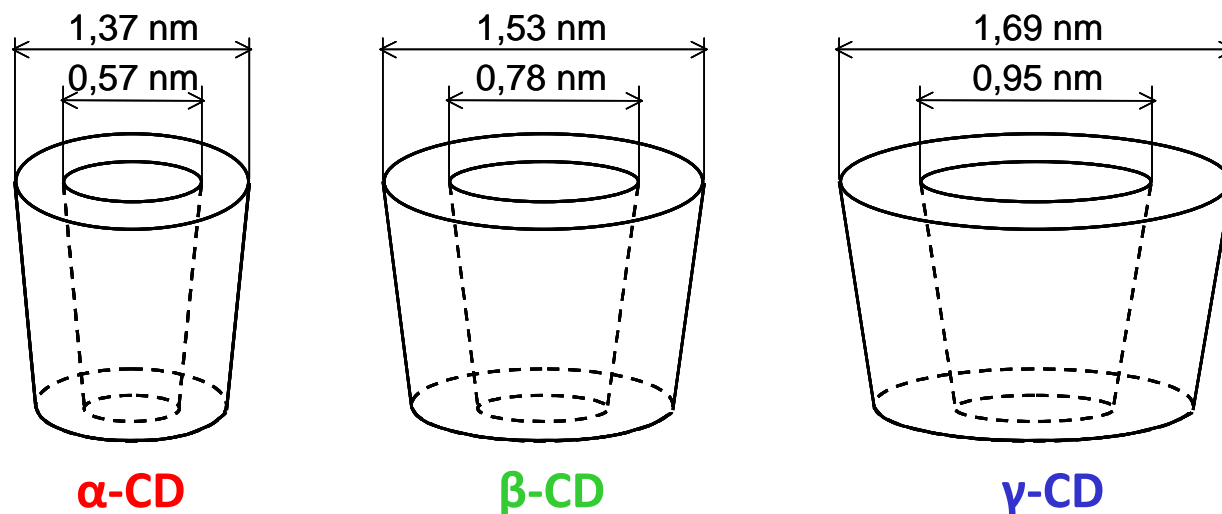

Structures and cavity sizes of the three natural cyclodextrins

✓ Cyclodextrins (CDs) are toroidally shaped polysaccharides with a highly hydrophobic central cavity which allows them to form inclusion complexes with many organic substrates.

✓ Cyclodextrin inclusion complexes are simple and useful models for the investigation of host-guest interactions in supramolecular systems [2].

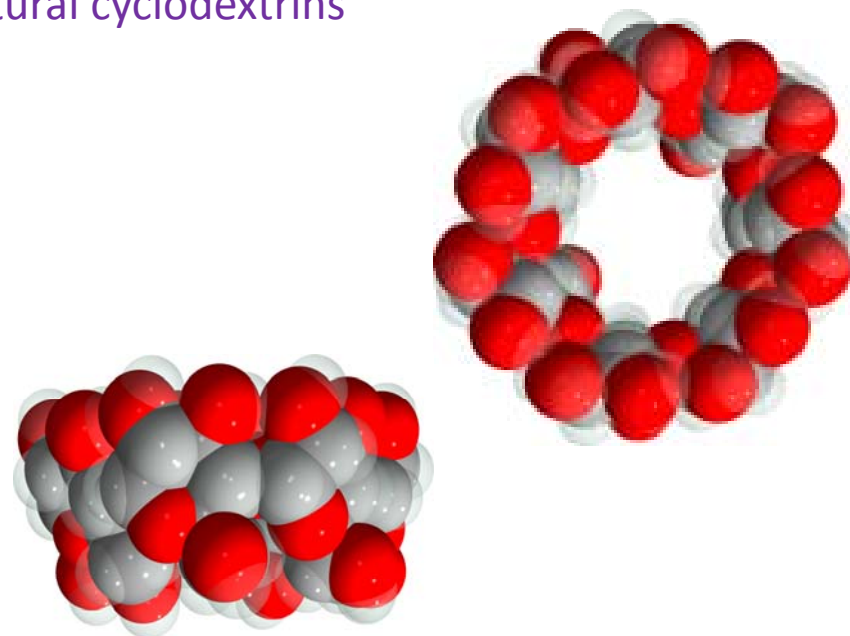

RESULTS AND DISCUSSION: Fluorescence titrations

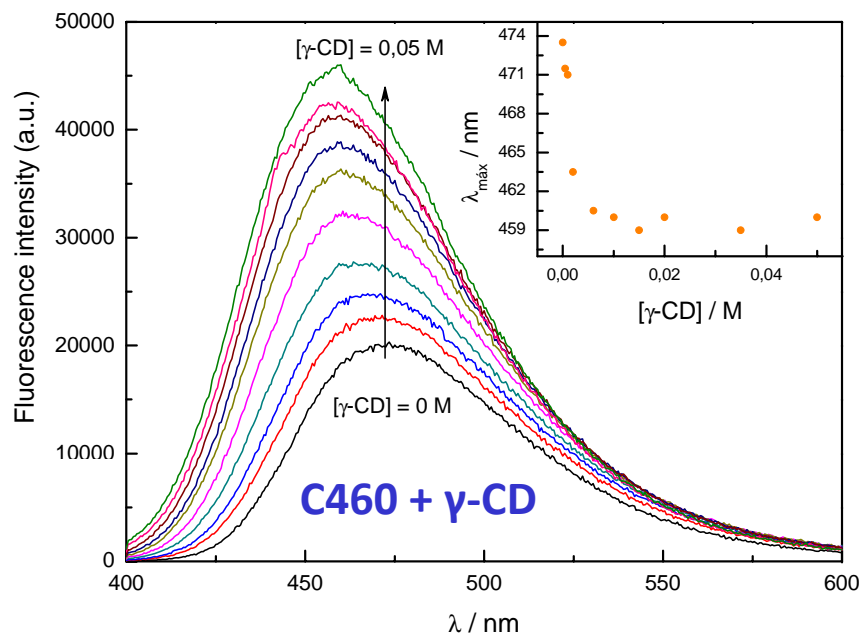
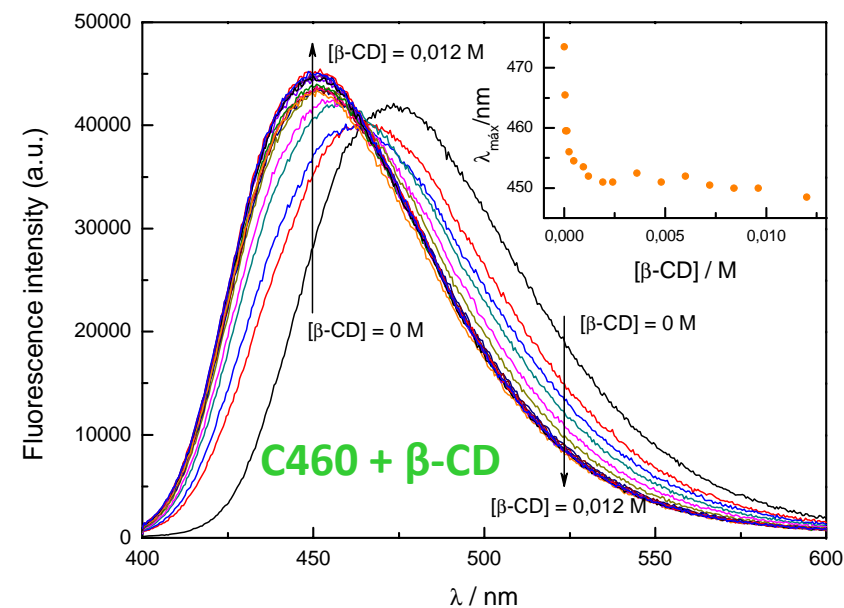
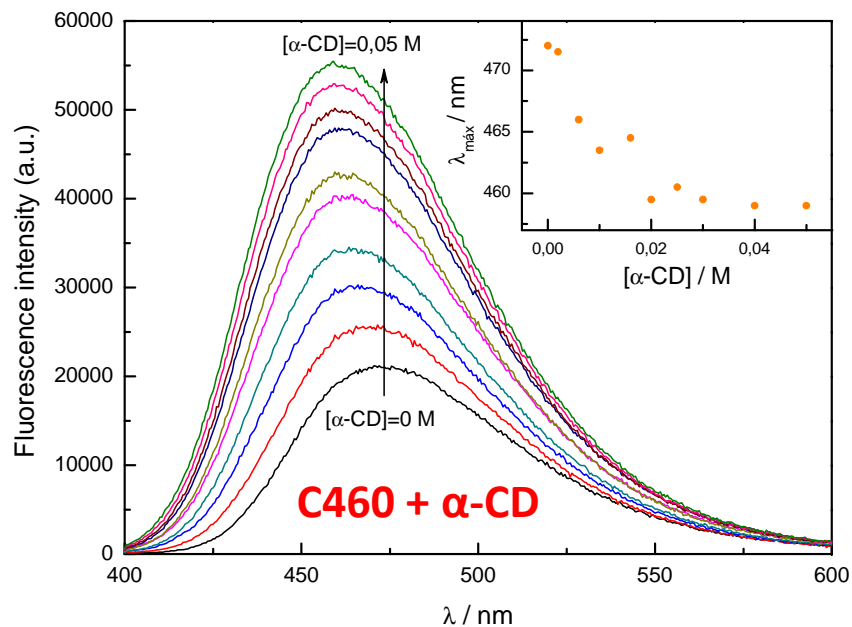

The figures show the variations of the fluorescence emission spectrum of C460 with increasing concentrations of the CDs. The insets are plots of the emission maxima versus CD concentration.

By increasing the concentration of CD we observed:

- ✓ A huge increase of the fluorescence intensity for $\alpha\text{-CD}$ and $\gamma\text{-CD}$ but not for $\beta\text{-CD}$.
- ✓ The fluorescence emission spectrum of the coumarin shifts to lower wavelengths.

RESULTS AND DISCUSSION: Model and data analysis

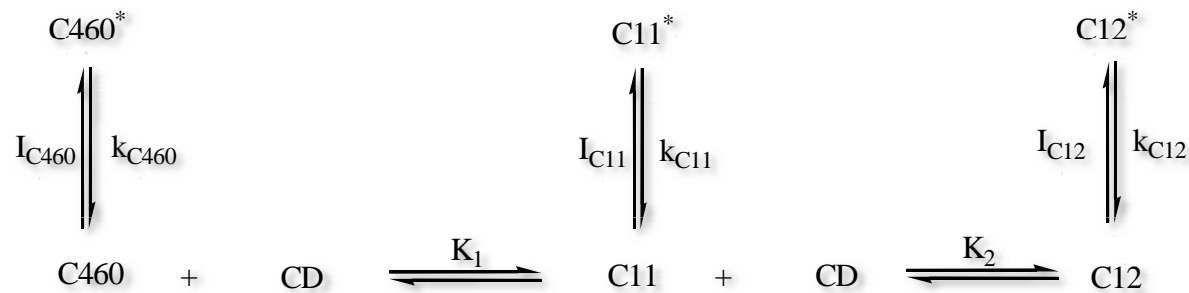

Proposed mechanism and fit function (K_2 only for γ -CD).

$$F^\lambda = \frac{a^\lambda + b^\lambda \cdot K_1 \cdot [\text{CD}]_0 + c^\lambda \cdot K_1 \cdot K_2 \cdot [\text{CD}]_0^2}{1 + K_1 \cdot [\text{CD}]_0 + K_1 \cdot K_2 \cdot [\text{CD}]_0^2}$$

Individual fits of the model functions to the fluorescence intensity versus CD concentration data. Fit parameters are the association equilibrium constants K_1 and K_2 and the fluorescence intensities of free C460 and complexes C460:CD and C460:CD₂ (only for γ -CD).

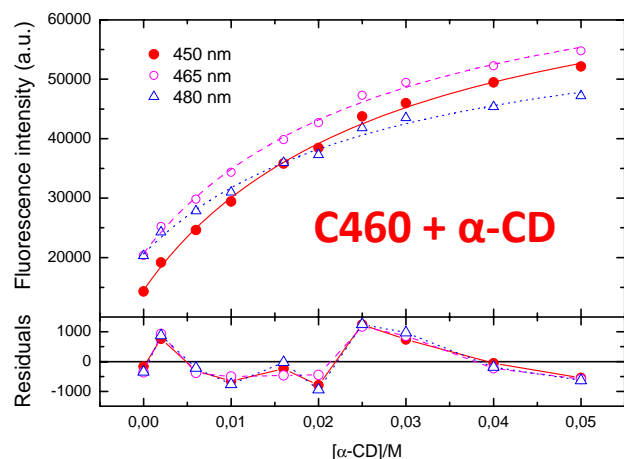

**Only 1:1
complex**

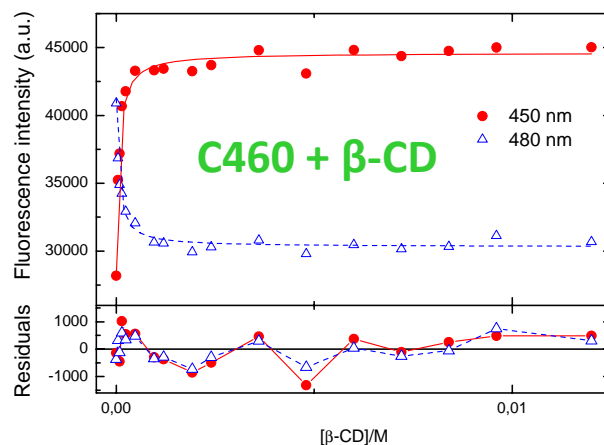

**Only 1:1
complex**

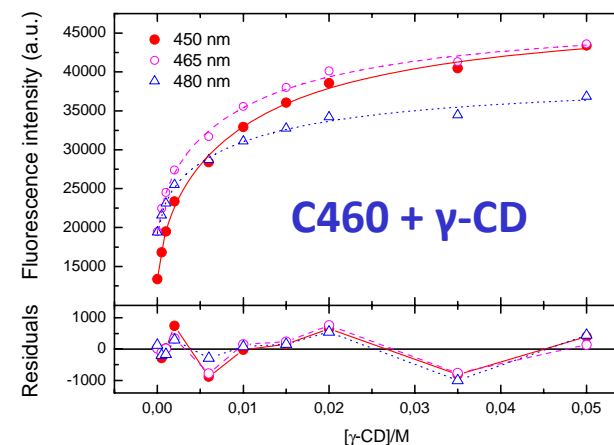

**1:1 + 1:2
complexes**

RESULTS AND DISCUSSION: Global Analysis

Global analysis with the whole emission spectra as dataset yield more precise values of the association equilibrium constants K_i and the fluorescence spectra of the free coumarin and the coumarin bound to the different CDs forming 1:1 or 1:2 complexes [3,4].

System	C460 + α -CD	C460 + β -CD	C460 + γ -CD
Fluorescent Components	2 (C460 + C11)	2 (C460 + C11)	3 (C460 + C11 + C12)
K_1 / M^{-1}	34.6 ± 0.2	14880 ± 70	692 ± 20
K_2 / M^{-1}	-	-	50 ± 2

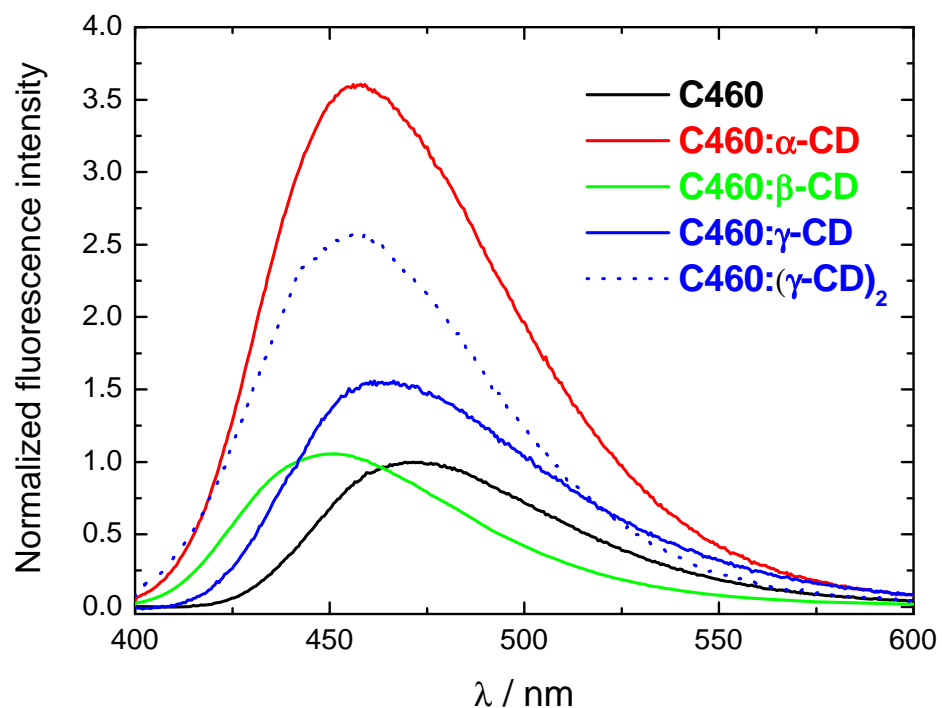

✓ Complex C460: β -CD shows much higher stability constant than the others.

✓ Normalizing the emission spectra of free coumarin, the spectra of the 1:1 complexes show unexpected differences among them.

✓ Both the increase in fluorescence intensity and the spectral shift of the 1:1 complexes with respect to free C460 do not correlate in a simple way with the cavity size.

RESULTS AND DISCUSSION: Interpretation of quantum yields and fluorescence lifetimes

Fluorescence quantum yields and lifetimes of free coumarin and its complexes with CDs.

System	Q	τ /ns	k_r /ns ⁻¹	k_{nr} /ns ⁻¹
C460 in water	0.070	0.40	0.18	2.3
C460:α-CD	0.28	1.75	0.16	0.41
C460:β-CD	0.070	0.30 2.1		
C460:γ-CD	0.14	0.78	0.18	1.1
C460:(γ-CD)₂	0.21	2.0	0.10	0.40

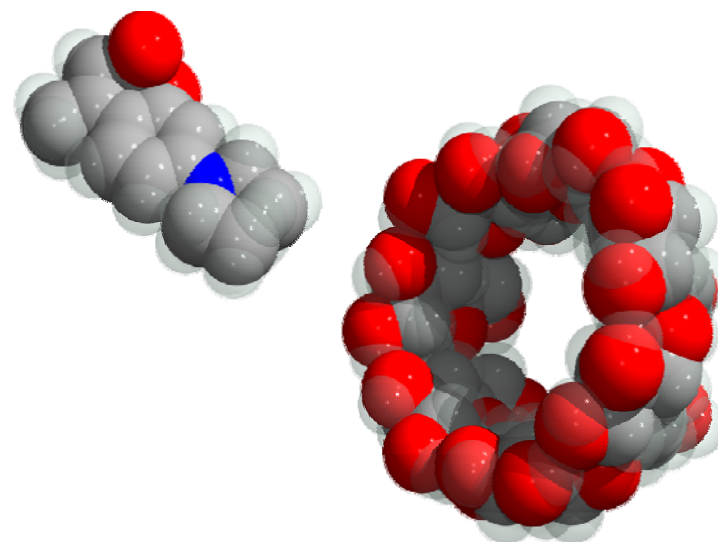

✓ Low values of Q and τ are explained as a result of TICT state predominance [5,6].

✓ High values of Q and τ are explained by the predominance of the ICT state indicating that complexation affects to the amino group and hinders the charge transfer.

✓ Intermediate values of Q and τ indicate coexistence of both ICT and TICT state.

✓ Two lifetimes for the system C460: β -CD denotes two types of 1:1 complexes [4].
(*Fit function would not change, since $[C1a]/[C1b]=K1a/K1b=cte$, then $K=K1a+K1b$)

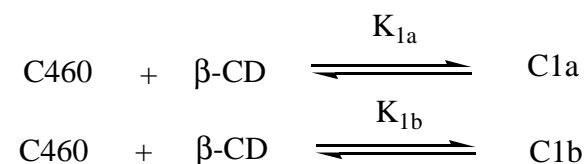

✓ Both types of C11 may also exist for C460 + γ -CD system, but the corresponding lifetimes cannot be resolved.

CONCLUSION: Size-dependency of structure and stability of the complexes

The following structures are proposed for the complexes of C460 with the different CDs:

C460 + α -CD

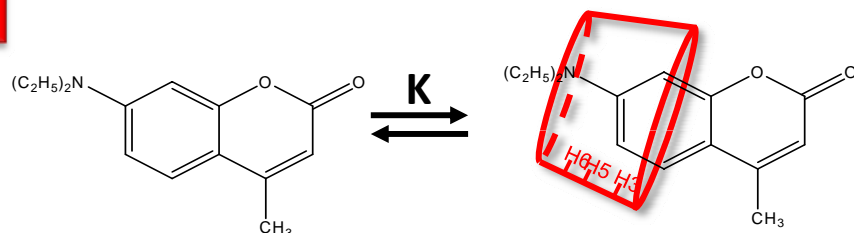

Q \uparrow (TICT state inhibited)

C460 + β -CD

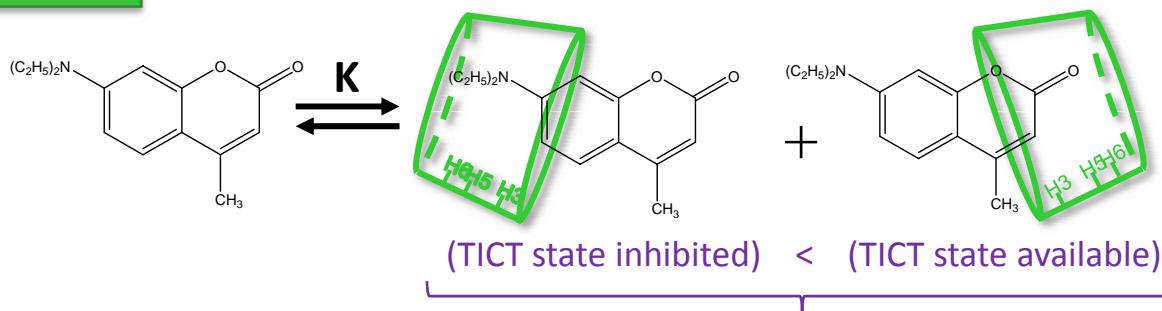

(TICT state inhibited) < (TICT state available)

Q \downarrow

C460 + γ -CD

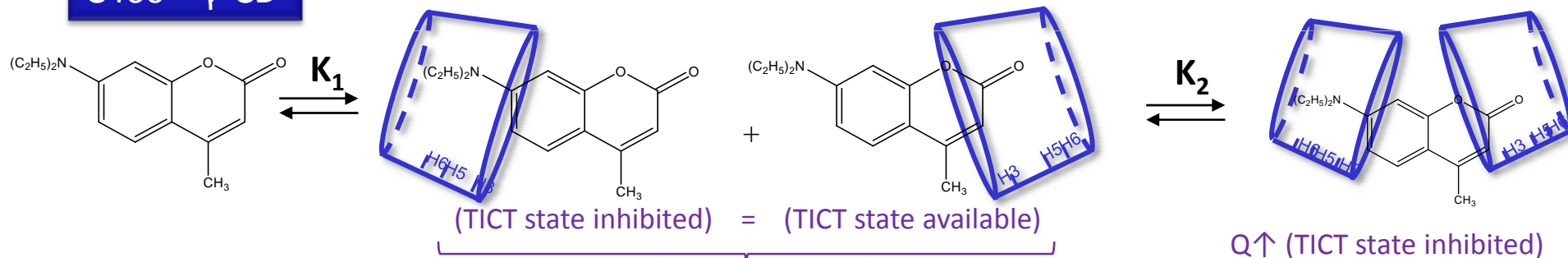

(TICT state inhibited) = (TICT state available)

Q \rightarrow

Q \uparrow (TICT state inhibited)

REFERENCES:

References cited:

- [[1] Grabowski, Z. R.; Rotkiewicz, K.; Rettig, W. Structural Changes Accompanying Intramolecular Electron Transfer: Focus on Twisted Intramolecular Charge-Transfer States and Structures. *Chem. Rev.* **2003**, *103*, 3899-4031.
- [2] Szejtli, J. Introduction and General Overview of Cyclodextrin Chemistry. *Chem. Rev.* **1998**, *98*, 1743-1754.
- [3] Al-Soufi, W.; Novo, M.; Mosquera, M. Principal Component Global Analysis of Fluorescence and Absorption Spectra of 2-(2'-Hydroxyphenyl)Benzimidazole. *Appl. Spectrosc.* **2001**, *55*, 630-636.
- [4] Alvarez Parrilla, E.; Al-Soufi, W.; Ramos Cabrer, P.; Novo Rodríguez, María de la Merced; Vázquez Tato, J. In *Resolution of the association equilibria of 2-(p-toluidinyl)-naphthalene-6-sulfonate (TNS) with [Beta]-cyclodextrin and a charged derivative*; 2001; .
- [5] Jones, G. I.; Jackson, W. R.; Halpern, A. M. Medium Effects on Fluorescence Quantum Yields and Lifetimes for Coumarin Laser Dyes. *Chemical Physics Letters* **1980**, *72*, 391-395.
- [6] Yip, R. W.; Wen, Y. X.; Szabo, A. G. Decay Associated Fluorescence Spectra of Coumarin 1 and Coumarin 102: Evidence for a Two-State Solvation Kinetics in Organic Solvents. *J. Phys. Chem.* **1993**, *97*, 10458-10462.

Acknowledgements:

We acknowledge the collaboration of Dr. Belén Reija and Arturo Teijeiro and the financial support by the Ministerio de Ciencia e Innovación (project CTQ2007-68057-C02-02_BQU).