

Corrosion of Post-Tension Tendons associated with Segregated Grout



Photos by courtesy of Lau et al.,2011 and Lau et al.,2016

Samanbar Permeah and Kingsley Lau
Florida International University , Dept. of Civil & Environmental Engineering

CMDWC2021. May 17-19,2021

Background

Corrosion of PT Tendon

- Post-tensioned, PT, concrete bridge construction allows for a wide range of design possibilities.
- For bonded tendons, the high strength steel strand is stressed and encapsulated with grout that provides barrier protection against corrosion.
- However, there have been several cases of corrosion in Florida bridges related to:
 - Degraded protection at joints (moisture and chloride)
 - Development of void spaces due to the formation of bleed water



Photos by courtesy of Lau et al.,2016

These issues have proven the importance of having good grout quality to extend the service life of bonded post-tensioned tendons.



Grout Segregation

- Recent cases involved low-bleed thixotropic grouts that developed physically and chemically deficient segregated grout characterized as moisture-rich, low cement content and high concentrations of sulfate and alkali ions.

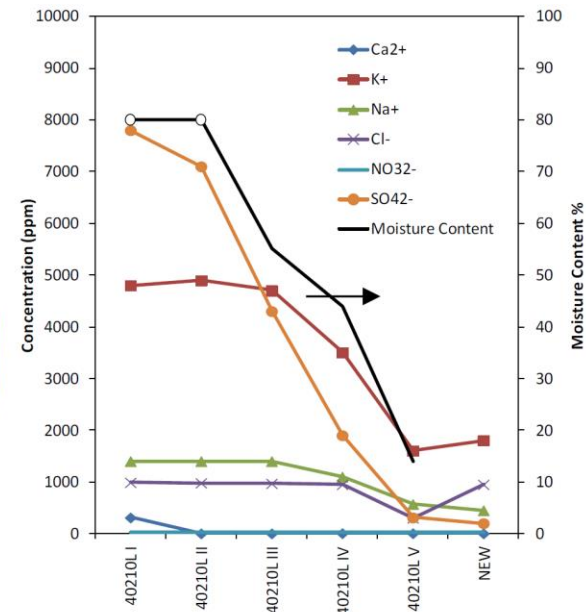
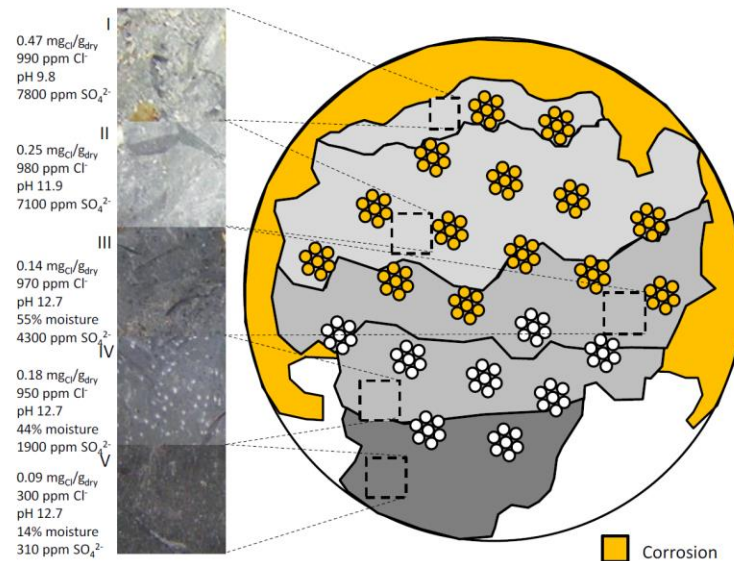

✓ Corrosion observed in deficient grout containing high moisture and enhanced sulfate levels.

Sulfate Limits for Deficient Grout

- Proposed 0.0007 g/g (7 ppm) as a nominal limit based on electrochemical activity of lab and field data considering discussions on the effects of solution pH (Permech et al., 2019).
- Complications due to interdependencies of cement hydration, pH, chloride, sulfate, etc on passive film formation as well as practical methodologies to sample deficient grout.
- In grout specimens, rust was observed when values exceeded that 0.01 g/g (100 ppm).
- Florida Spec. FM 5-618 0.003 g/g (30 ppm per method) sulfate limit. Commercially available grouts already meet this limit.

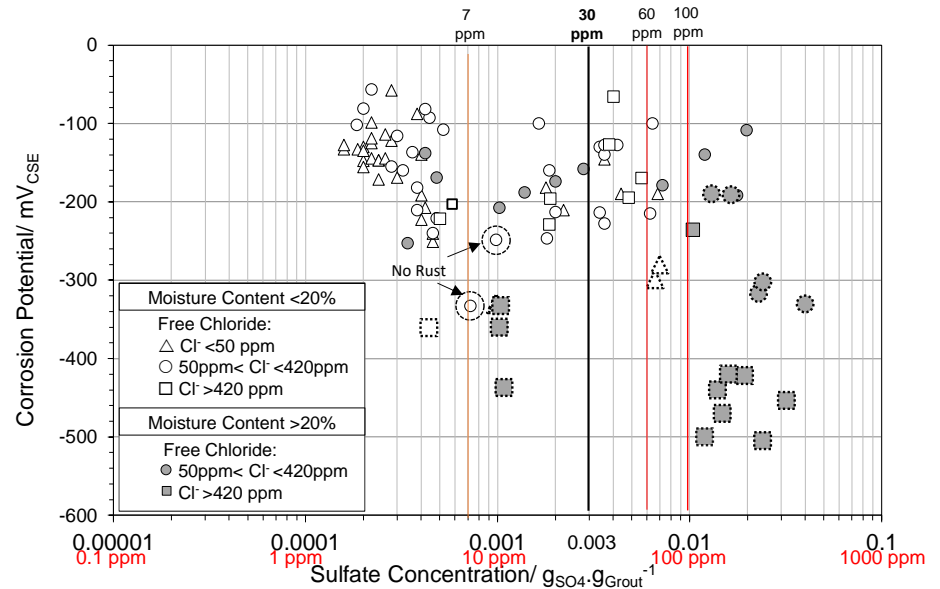
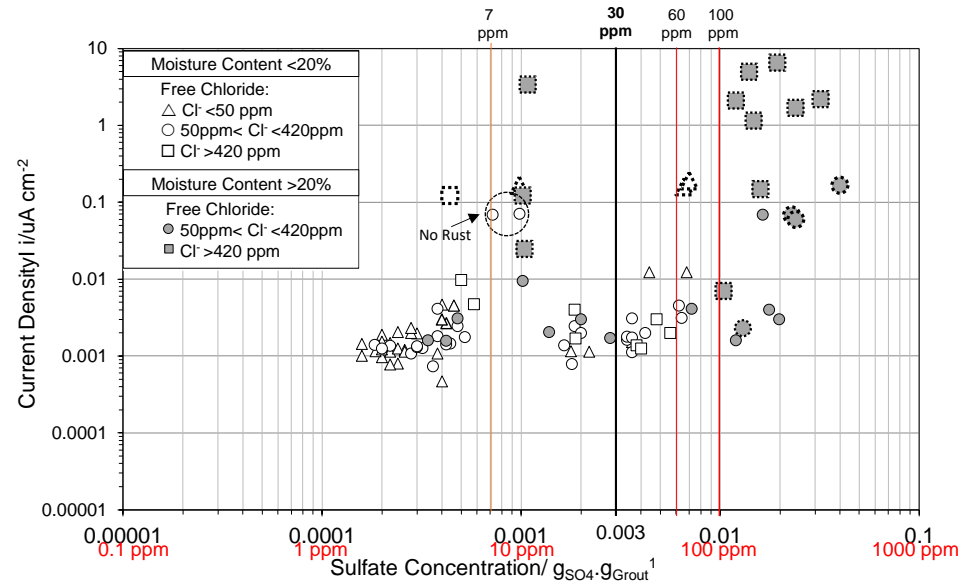

Electrochemical Techniques to Assess Corrosion

- The corrosion activity in deficient grout was associated with elevated sulfate levels in alkaline pore water solutions.
- Electrochemical measurements to assess the role of sulfates.
- In general, *open-circuit potentials* provide indication of active or passive behavior of steel and the *polarization resistance* provides estimation of general corrosion rates.
- However, the observation of morphology of damage observed in the bridge tendons would suggest that localized corrosion can develop. Preliminary lab testing in sulfate solutions showed possibility for pitting to occur.
- *Potentiodynamic polarization* scans show development of pitting corrosion.



Pitting Corrosion, (Vigneshwaran et al., 2018)

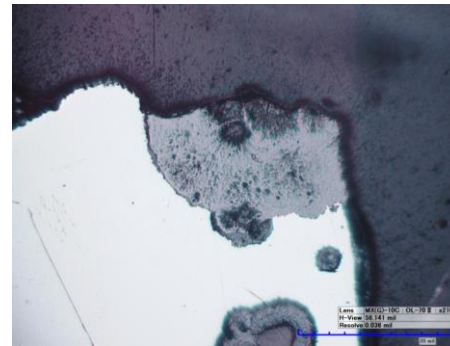

Pitting Corrosion, (Lau, 2011))

Electrochemical Techniques to Assess Corrosion

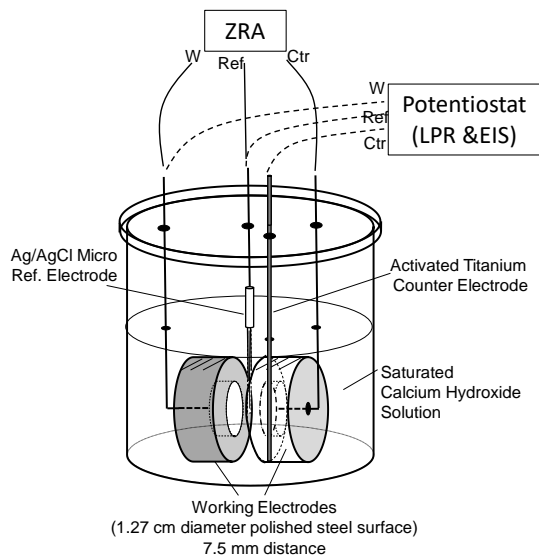

- Laboratory test setup to assess steel corrosion in alkaline sulfate solution (pH range 12.6-12.7).
- Testing included
 - Open-Circuit Potential
 - Linear Polarization Resistance (LPR)
 - Anodic Potentiodynamic Polarization (PD)
 - Electrochemical Noise (EN)
- Test cell placed in an aluminum enclosure (Faradaic cage)
- LPR and potentiodynamic polarization measured with Gamry Ref600 potentiostat.
- EN measured with Gamry ESA410 data acquisition program.

EN Test Settings

LPR scan rate 0.1 mV/s

PD scan rate (fwd 0.01 mV/s)
(rev 0.1 mV/s)

EN Test Settings- 1, 10, and 100 Hz acquisition rates.

Sulfate Levels	I-E Stability	I-E Range	E Channel Range	V Channel Range
0 to 20 g/L	Fast	6 – 600 nA	300 mV	300 mV
30 to 50 g/L	Fast	600 nA	3 V	3 V
100 g/L	Fast	600 nA -6 μ A	3V	3 V

Results of Electrochemical Measurements

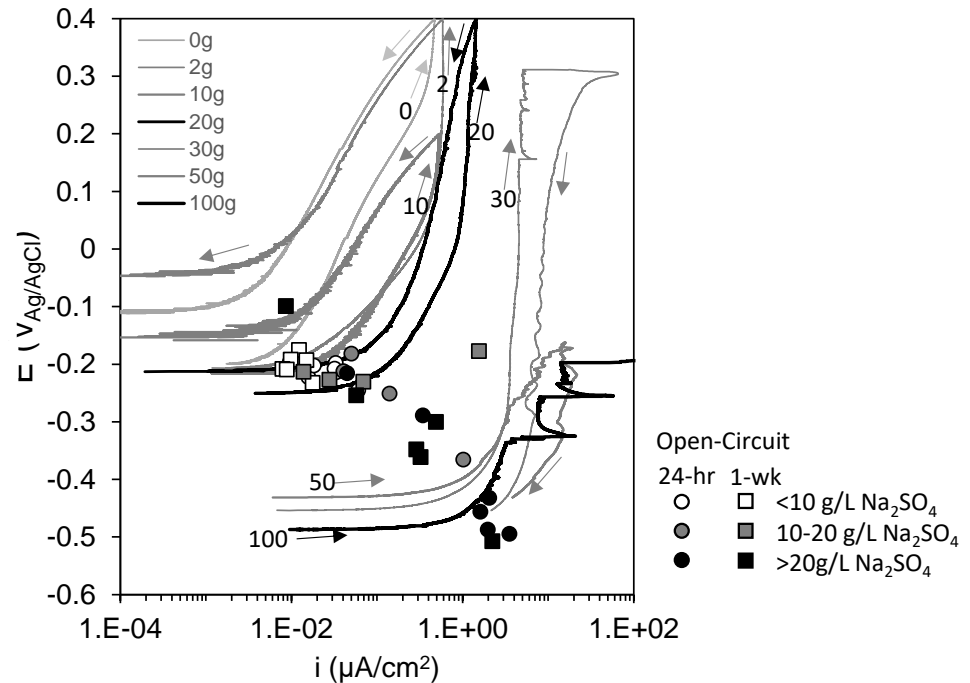
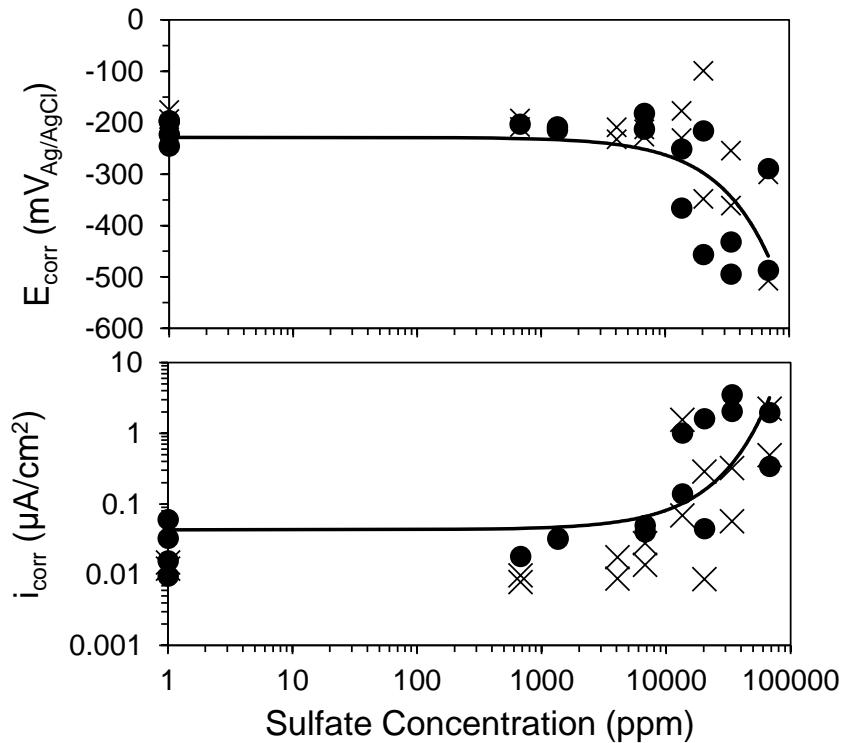

- The open-circuit potential of the steel showed electronegative potentials indicative of active corrosion at elevated sulfate concentrations in alkaline solution.
- The corrosion current density, correspondingly showed larger values.
- The results of anodic polarization tests showed a shift of the anodic current exchange density, resulting in larger corrosion currents. There were indications of metastable pitting in solutions at 10-20g/L Na₂SO₄ and pitting at higher concentrations.

Electrochemical Noise (Transient Noise Events)

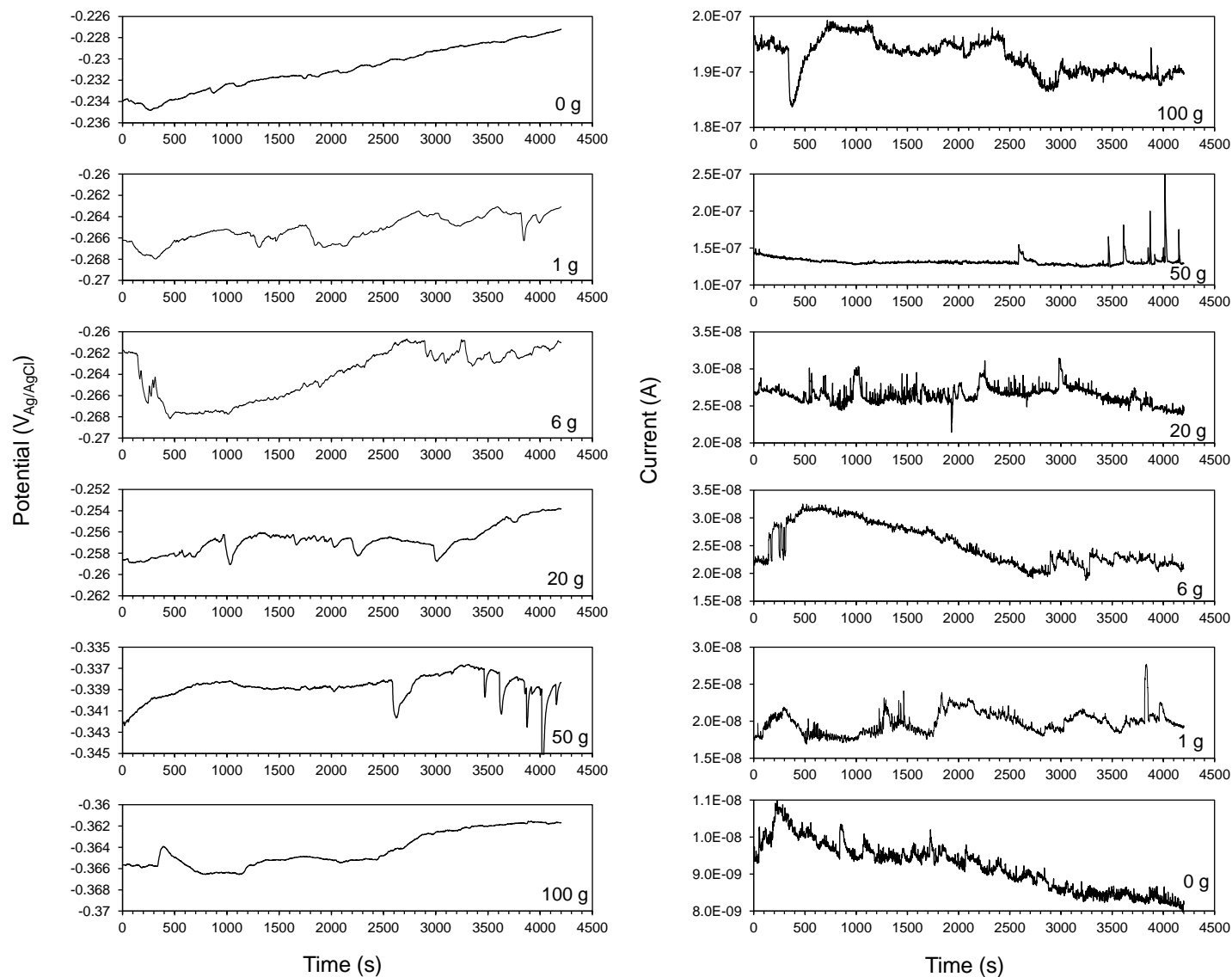

- More numerous and greater magnitude of noise potential and current events were observed with the higher concentrations of sulfates in alkaline solution.

Electrochemical Noise Spectral Analysis

- Electrochemical noise can be an effective measurement technique to assess the development of localized corrosion when utilizing appropriate anti-aliasing filters and instrument settings.
- Spectral analysis included potential and current power spectral density.
- Characteristics of transient noise events can be assessed from the PSD.

$$q = \frac{\sqrt{\Psi_{I0} \times \Psi_{E0}}}{B} \quad \text{Characteristic charge}$$

$$f_n = \frac{B^2}{\Psi_{E0}} \quad \text{Characteristic frequency}$$

$$I_{corr} = B \sqrt{\frac{\Psi_{I0}}{\Psi_{E0}}} \quad \text{Corrosion current}$$

$$Z_n(f) = (\Psi_E(f)/\Psi_I(f))^{0.5} \quad \text{Noise impedance}$$

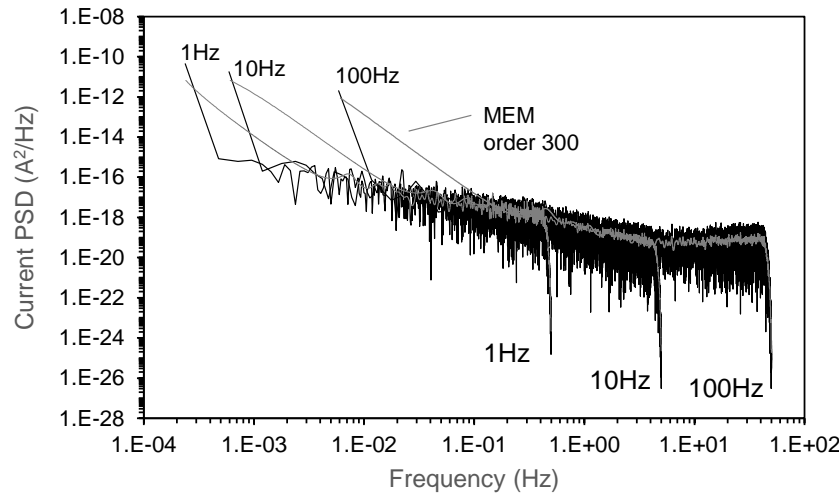
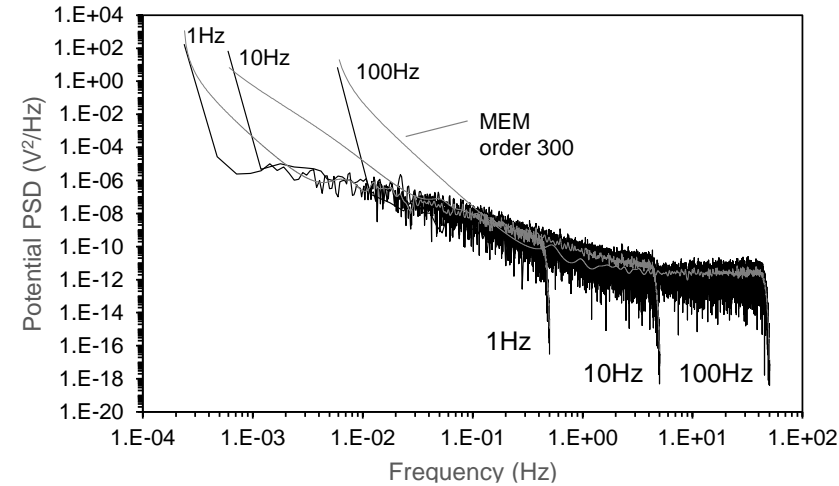

Electrochemical Noise Spectral Analysis

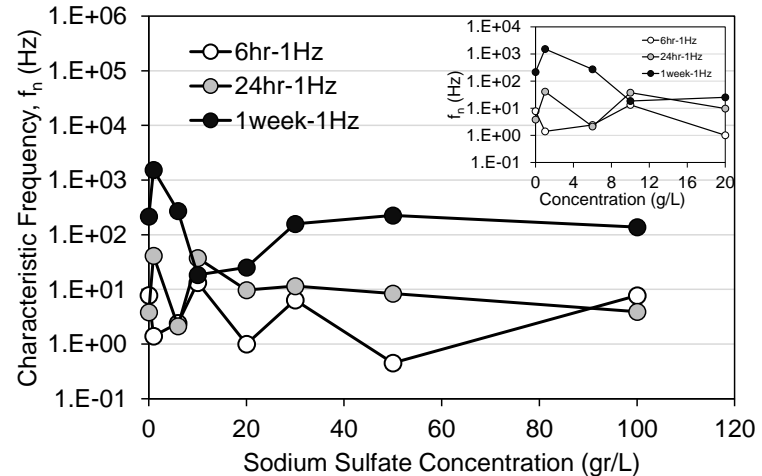
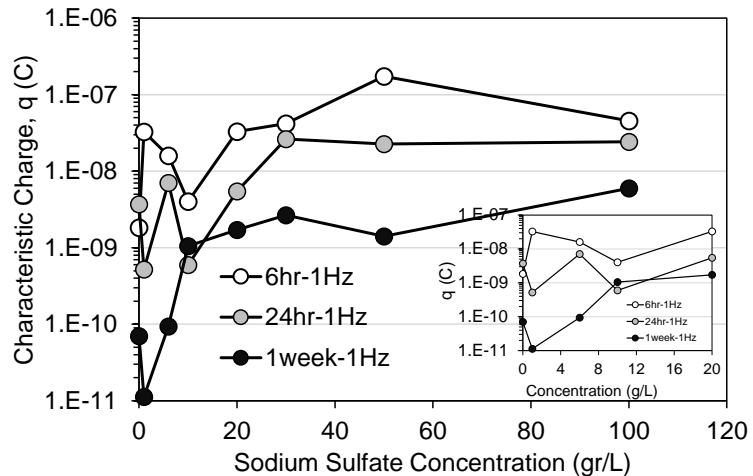

- The characteristic charge had greater magnitudes at higher sulfate concentrations.
- The characteristic frequency decreased at higher sulfate concentrations.
- This would indicate that more frequent and larger anodic events developed at higher sulfate concentrations in alkaline environments.

Electrochemical Noise (Corrosion Rate)

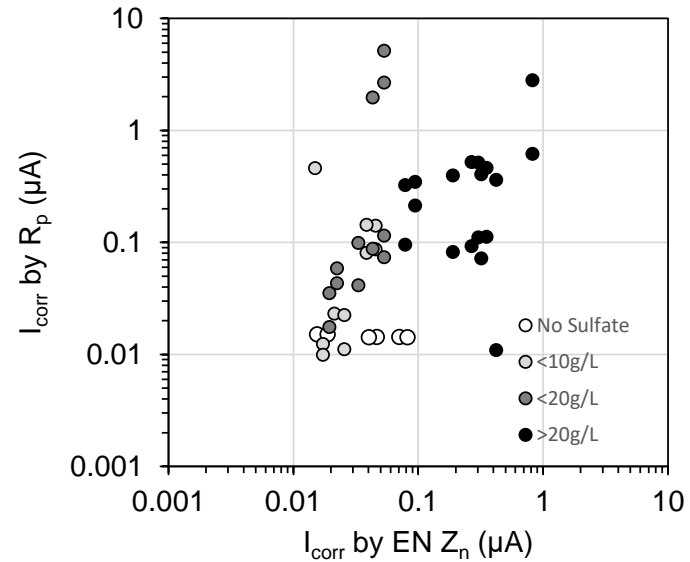
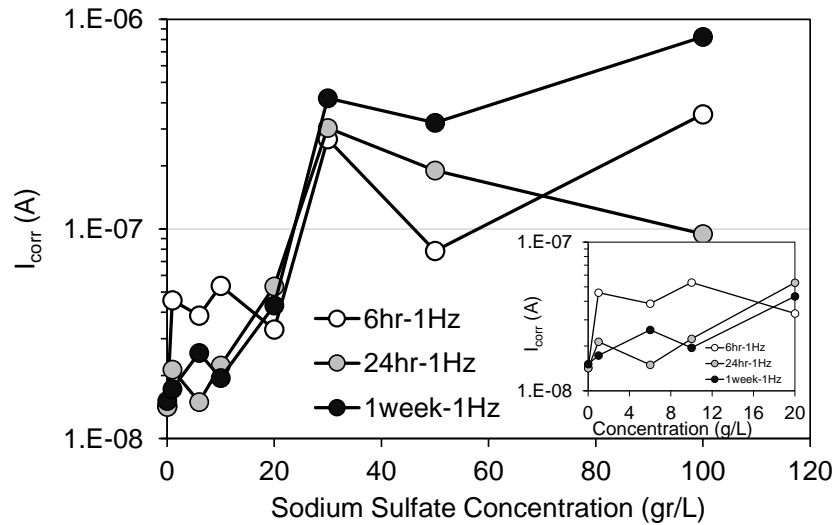

- The corrosion current resolved from EN measurements was greater at elevated sulfate concentrations in alkaline solutions.
- The corrosion current resolved by linear polarization resistance measurements and by electrochemical noise technique were well correlated.

Micrographs of Steel Corrosion

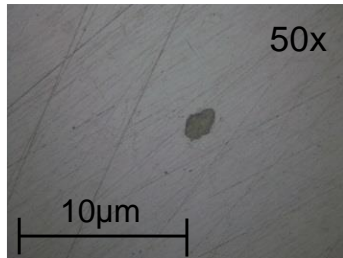

10 g Na₂SO₄ / L H₂O

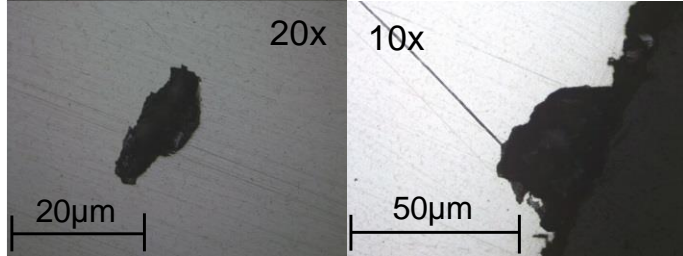

20 g Na₂SO₄ / L H₂O

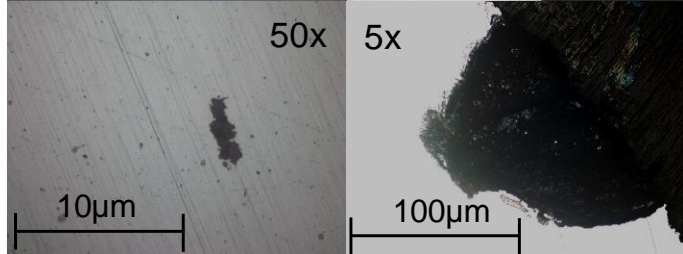

30 g Na₂SO₄ / L H₂O

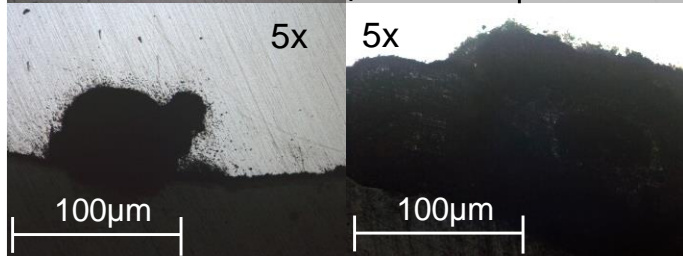

50 g Na₂SO₄ / L H₂O

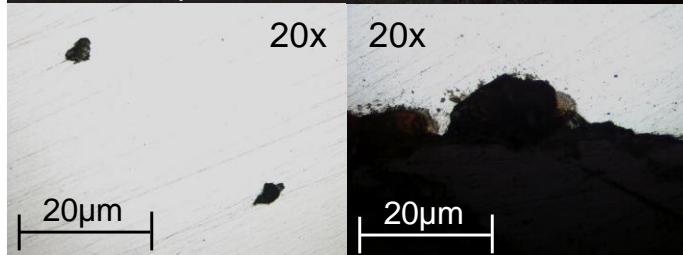

100 g Na₂SO₄ / L H₂O

- Micrographs of the steel specimens after immersion in sulfate solutions showed corresponding levels of pitting and corrosion.
- No corrosion was observed in the sulfate-free solution.
- Significant pits developed at sulfate concentrations greater than 30 g/L.
- State transportation departments have recently developed limits for grout material specifications.
- Proposed limit of 30 ppm following an ex-situ leaching method corresponds to ~4,000 ppm SO₄²⁻.
- This value corresponds to a conservative limit for the development of metastable pitting.

SUMMARY OF ELECTROCHEMICAL TECHNIQUES FOR ASSESSMENT OF SULFATES IN ALKALINE ENVIRONMENTS

- The *open-circuit potential* and *polarization resistance* gave general indication that steel corrosion can develop in alkaline sulfate environments.
 - Corrosion potentials dropped to electronegative potentials and
 - Corrosion currents increased at high sulfate concentrations.
 - Limits difficult to identify (Greater corrosion activity >10,000 ppm)
- The *anodic potentiodynamic polarization* measured showed conditions where steel passivity was retained, where metastable pitting can develop, and where pitting corrosion occurs.
 - Passive condition observed <2,000 ppm
 - Metastable pitting events developed 10,000-20,000 ppm
 - Pitting developed >30,000 ppm
- *Electrochemical noise* can be an effective measurement technique to assess the development of localized corrosion`
 - Characteristic charge increased and characteristic frequency decreased >10,000 ppm.
 - Resolved I_{corr} by EN and LPR were similar.