

## 1 Abstract

Affinity sensors represent one of the largest group of chemical and biological sensors. Basis of such type of sensors is artificial receptors. As artificial receptors conducting polymers are most common due to their chemosensitive properties. However many types of chemical sensors including sensors based on conducting polymers are characterized by very slow recovery of the sensor signal after exposure of analytes. It is a usual problem in the development of chemosensitive materials for chemical conductometric sensors where it is necessary an optimization of the receptor affinity to get the higher sensitivity and selectivity. Therefore, a number of low selective receptors with different chemosensitive properties are combined into arrays to improve selectivity of the whole system. Here, we present a new concept: a virtual sensor array based on integrated electrochemical transistor consisting from a single sensing elements whose affinity properties can be regulated by external electrical potential.

## 2 Integrated electrochemical transistor

An electrical control of the redox-state of the polymer (polyaniline) was performed in five-electrode configuration with four electrodes for conductivity measurements by s24 technique and Ag/AgCl reference electrode integrated on the same glass chip. Using an ionic liquid was provided electrical connection between the reference electrode and chemosensitive material

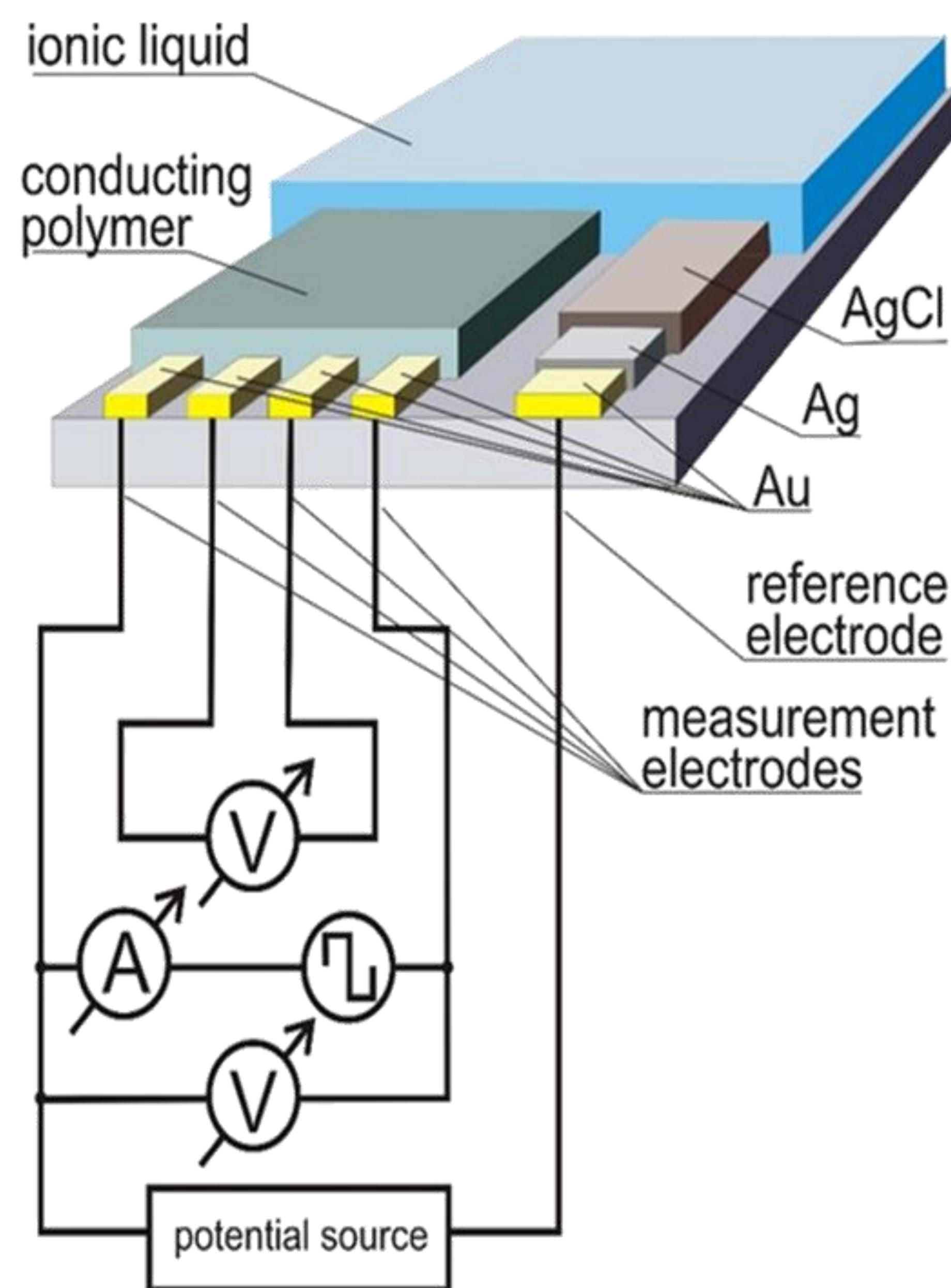

## 3 Sensor characterization

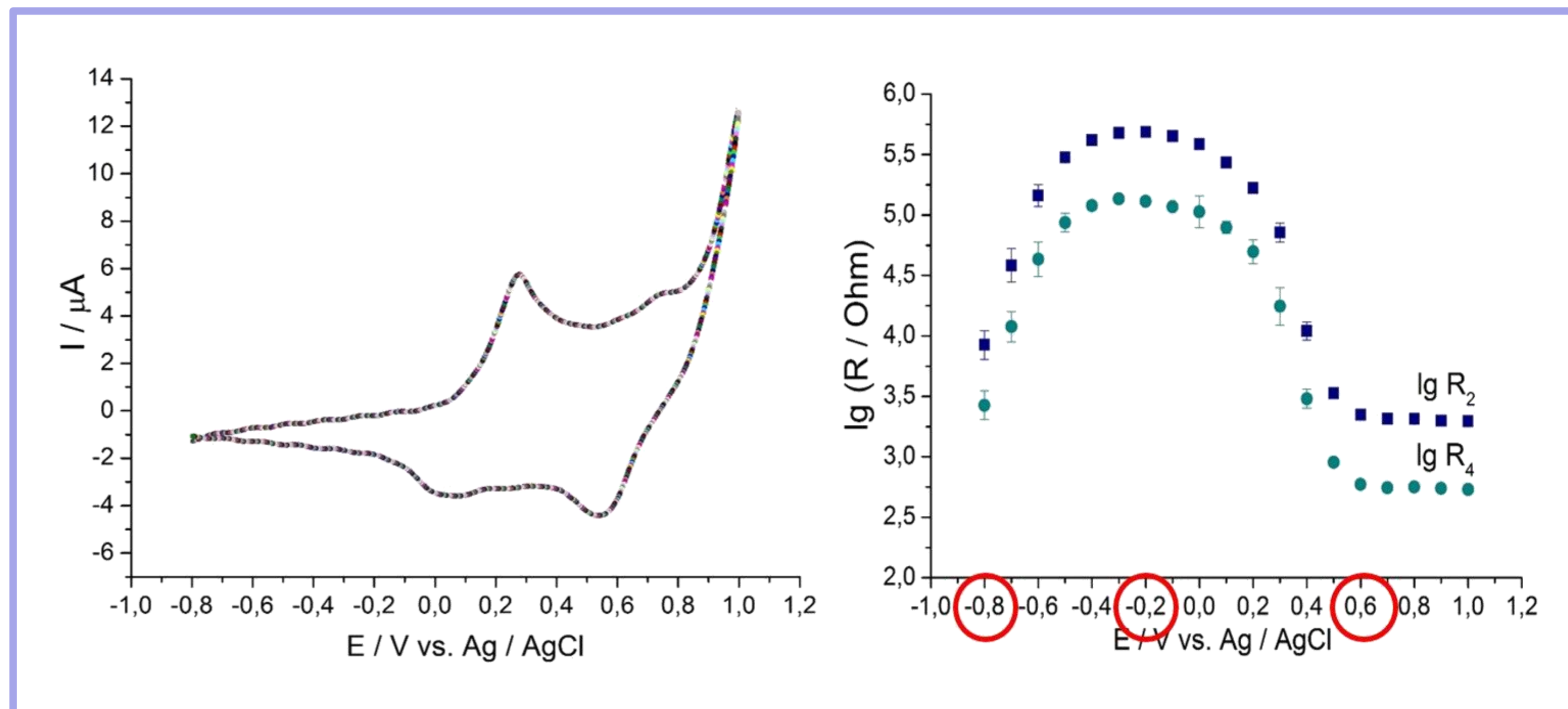

## 4 Electrical control of the receptor affinity

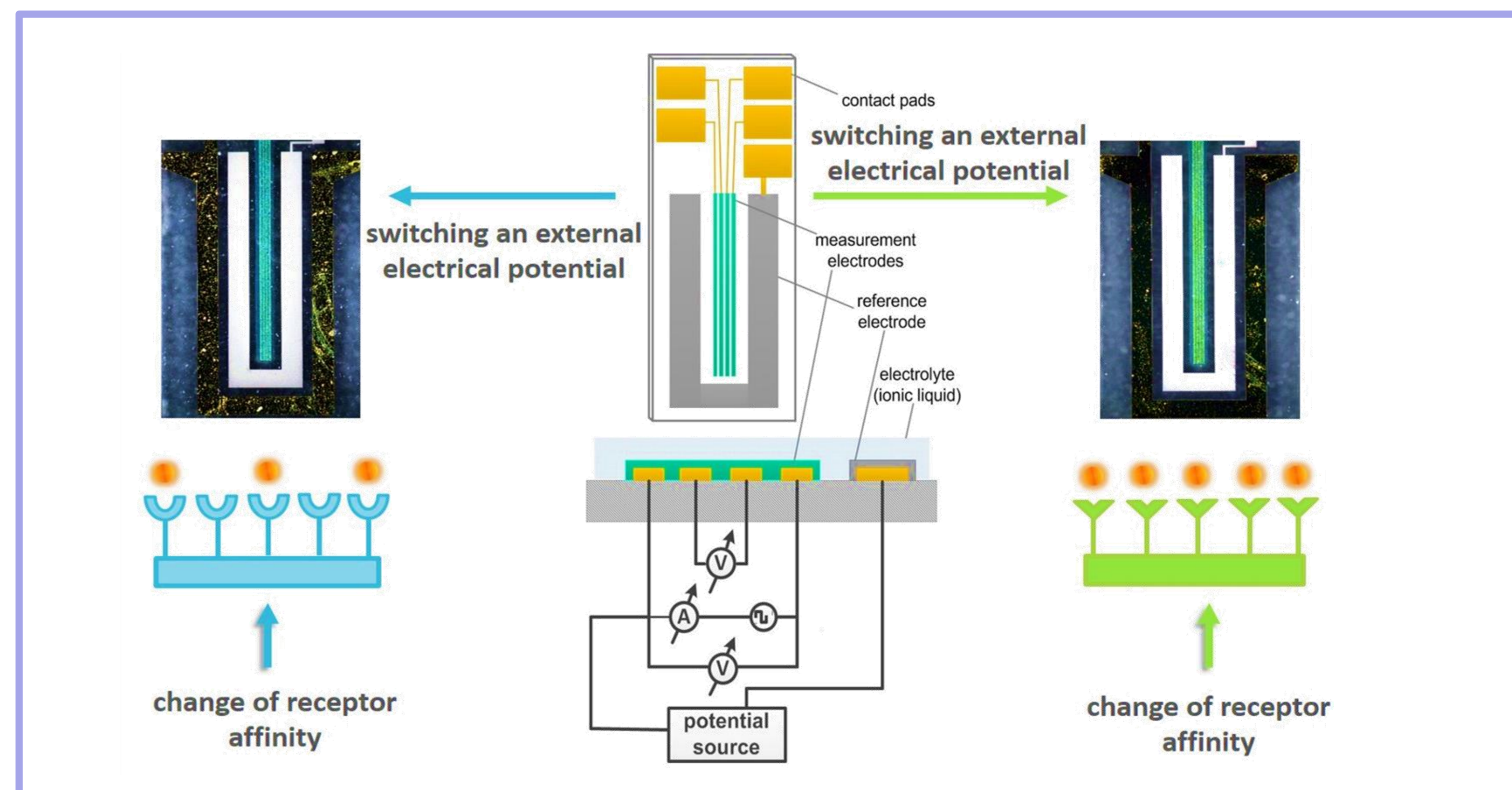

## 5 Monitor of fish freshness

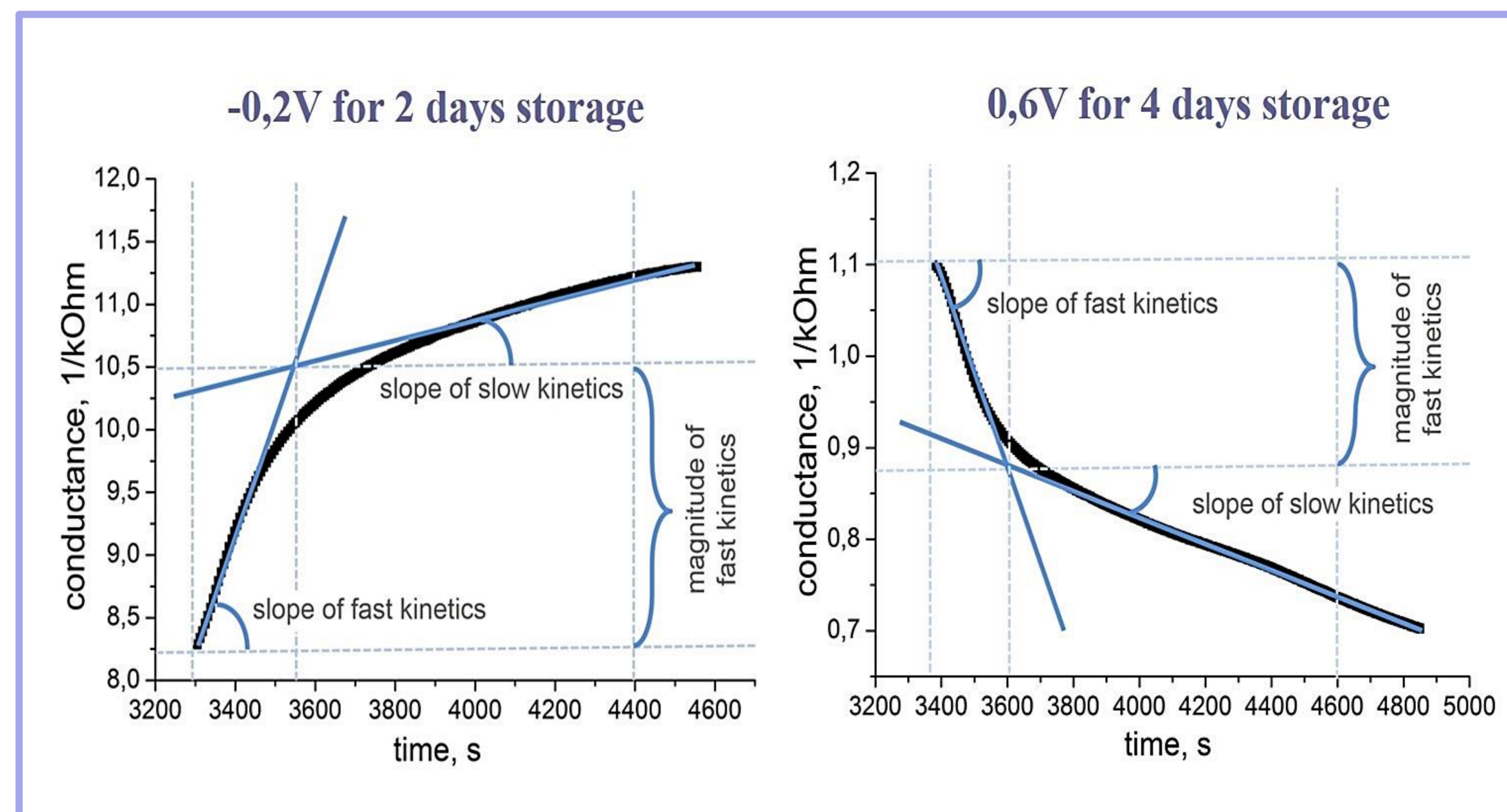

## 6 Outlook

- ✓ New concept for electrical control of sensor affinity
- Extension of this approach to create chemical sensors with integrated logic
- ✓ New principle of gas sensing
- ✓ Fast sensor recovery
- ✓ Application for fish freshness analysis



## 1 Abstract

Affinity sensors represent one of the largest group of chemical and biological sensors. Basis of such type of sensors is artificial receptors. As artificial receptors most common are conducting polymers due to their chemosensitive properties. However many types of chemical sensors including sensors based on conducting polymers are characterized by very slow recovery of the sensor signal after exposure of analytes. It is a usual problem in the development of chemosensitive materials for chemical conductometric sensors where it is necessary an optimization of the receptor affinity to get the higher sensitivity and selectivity. Therefore, a number of low selective receptors with different chemosensitive properties are combined into arrays to improve selectivity of the whole system. Here, we present a new concept: a virtual sensor array based on integrated electrochemical transistor consisting from a single sensing elements whose affinity properties can be regulated by external electrical potential.

## 2 Integrated electrochemical transistor

An electrical control of the redox-state of the polymer (polyaniline) was performed in five-electrode configuration with four electrodes for conductivity measurements by s24 technique and Ag/AgCl reference electrode integrated on the same glass chip. Using an ionic liquid was provided electrical connection between the reference electrode and chemosensitive material

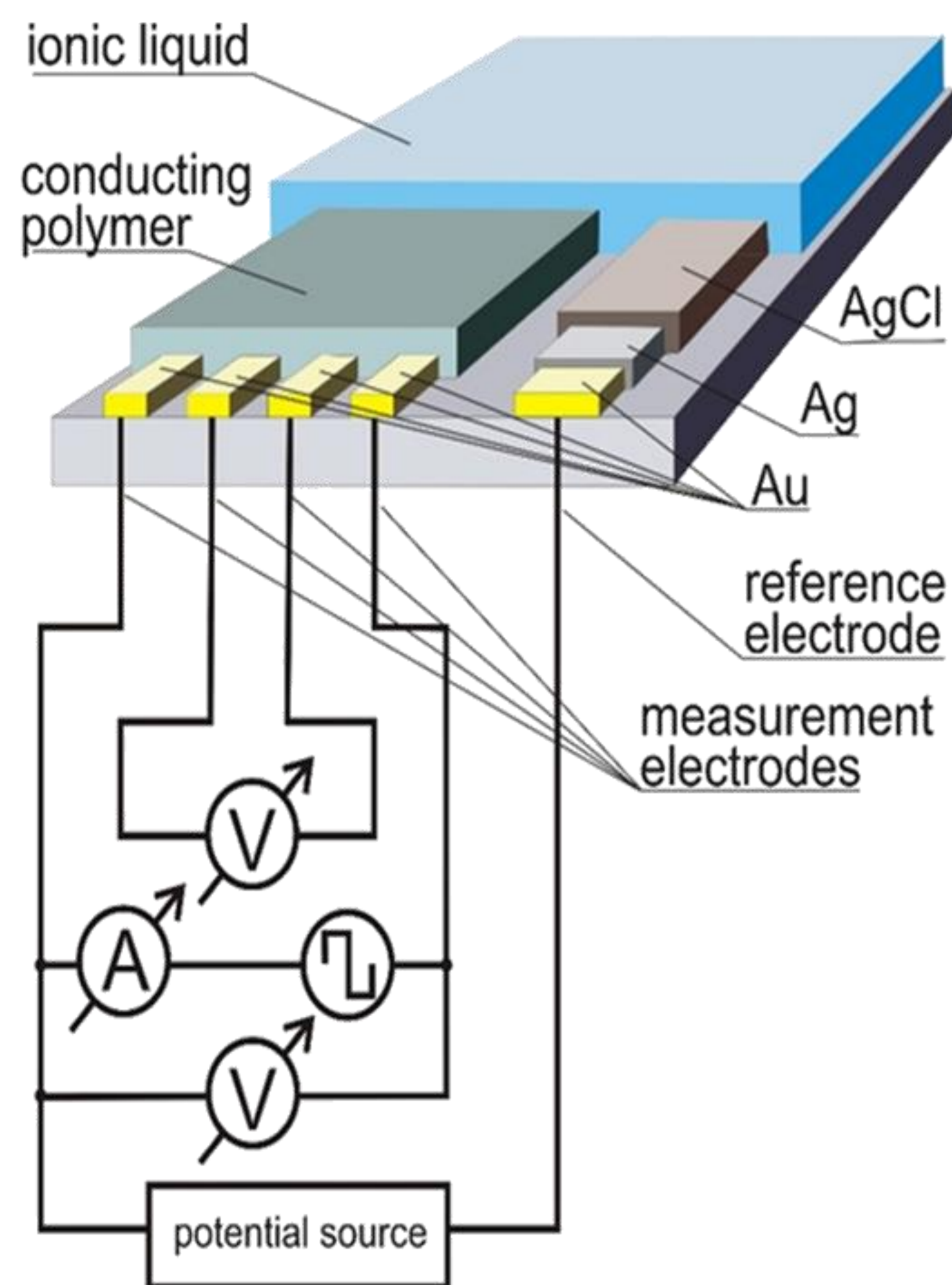

## 3 Sensor characterization

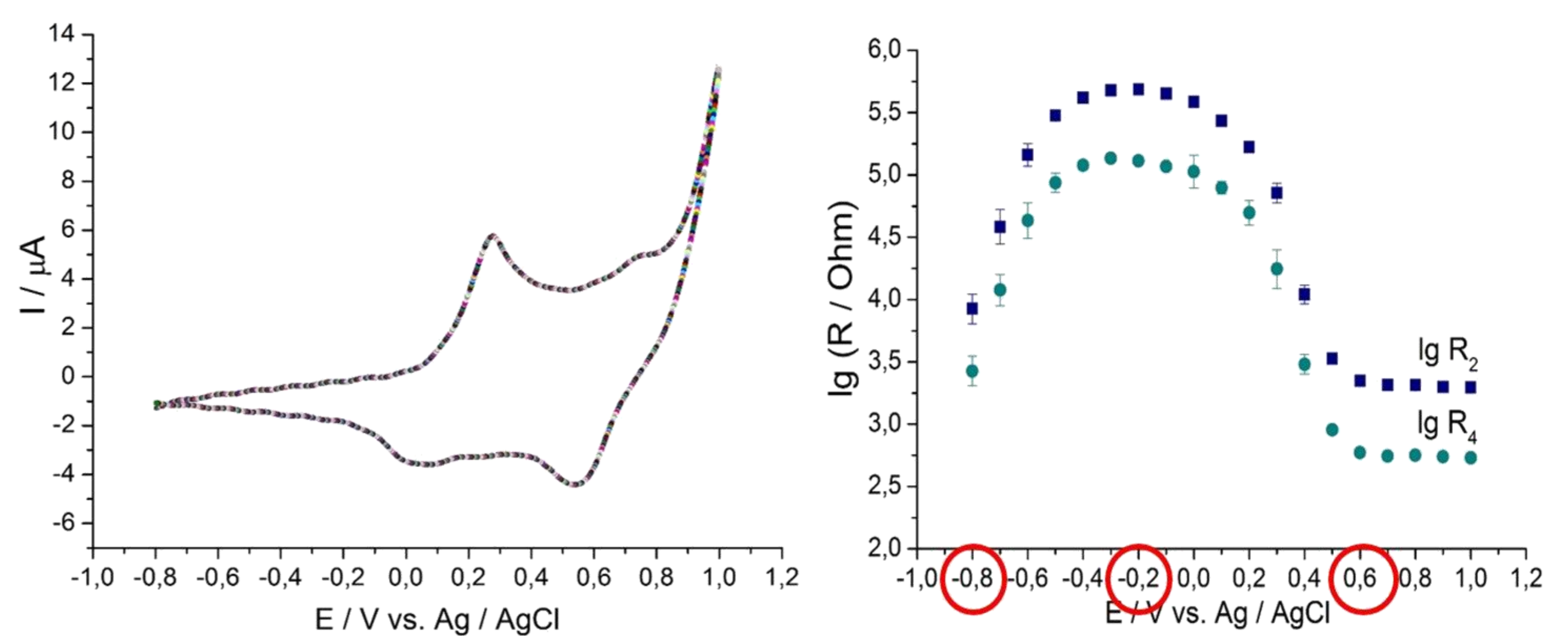

## 4 Electrical control of the receptor affinity

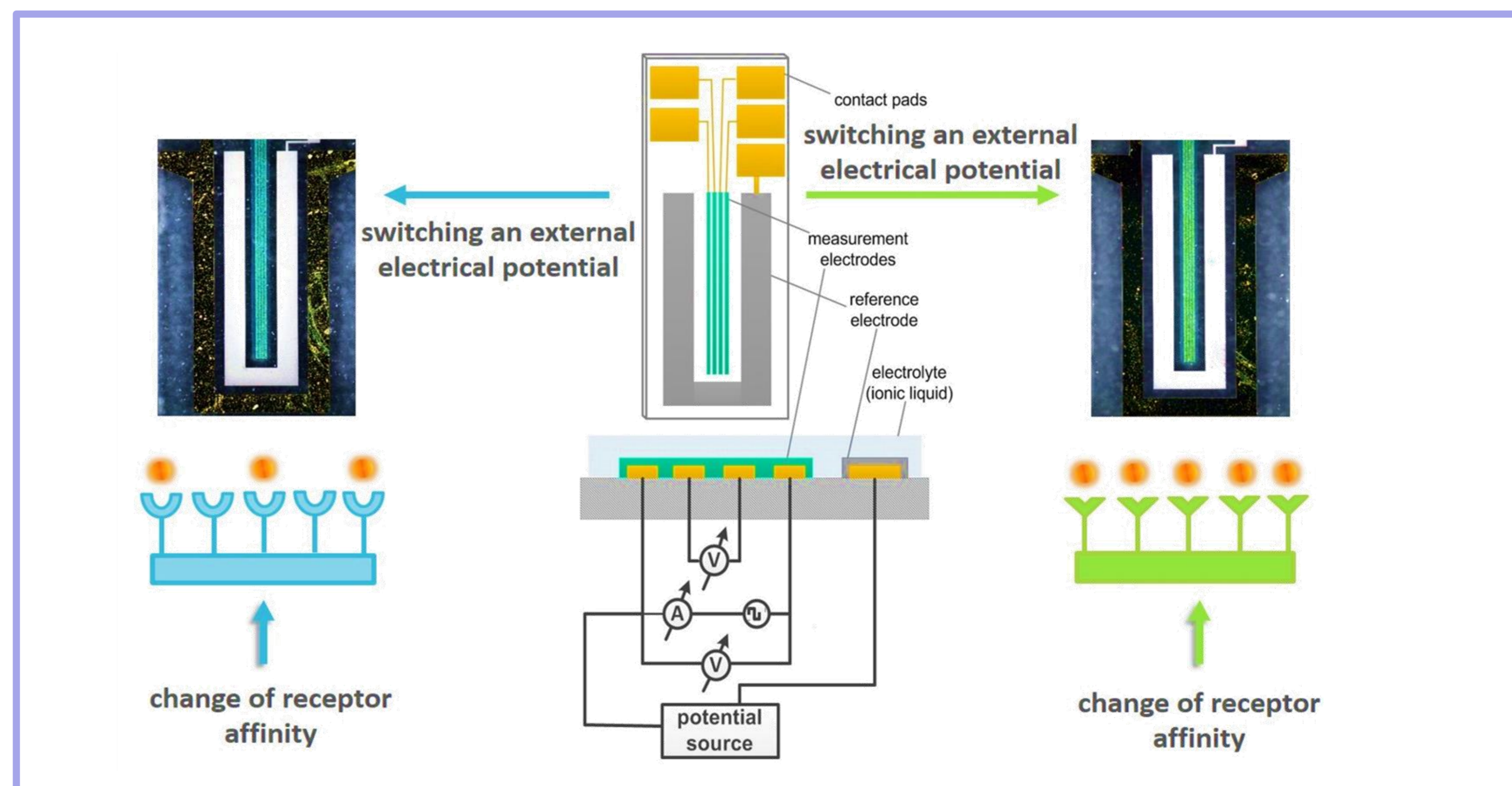

## 5 Monitor of fish freshness

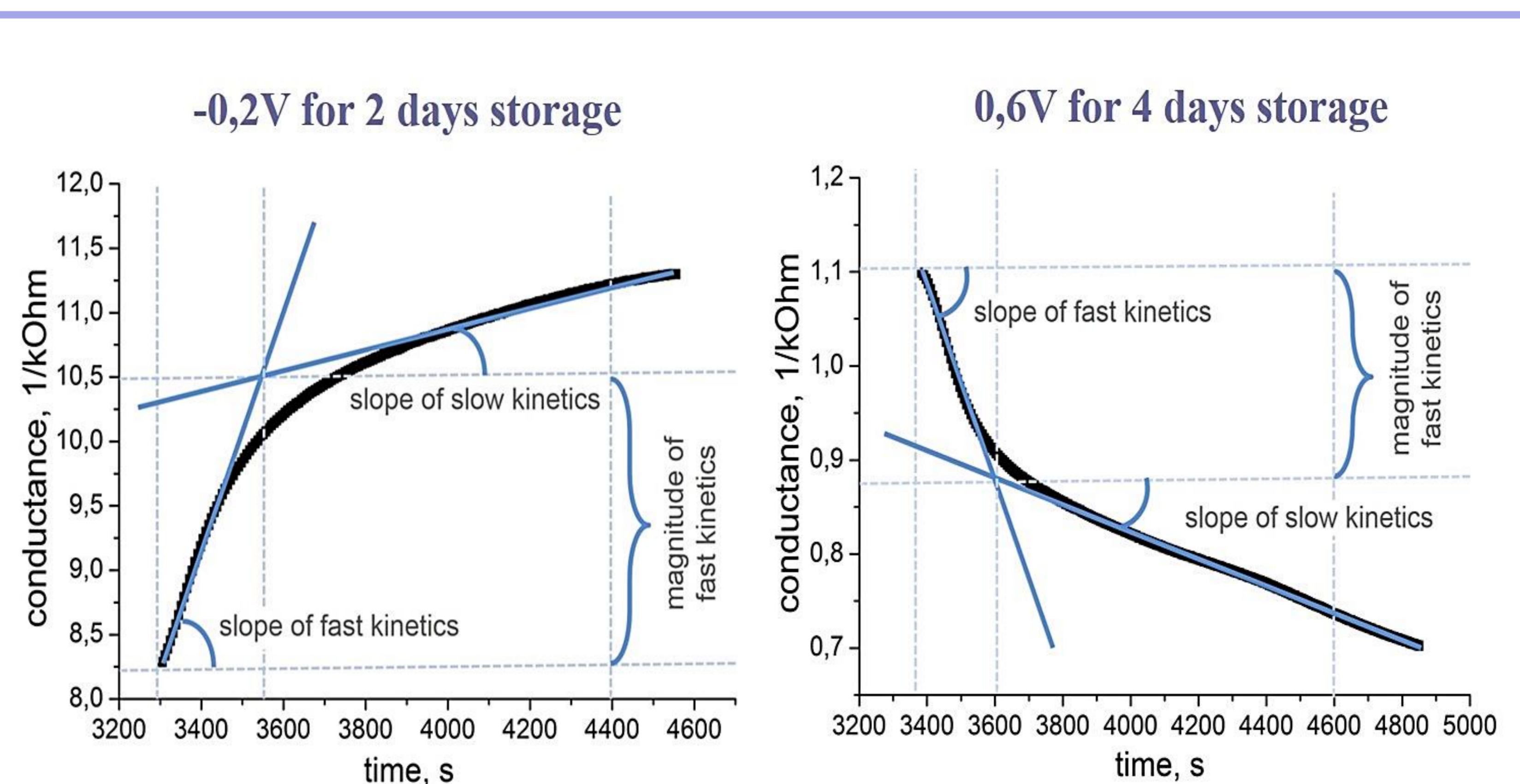

## 6 Outlook

- ✓ New concept for electrical control of sensor affinity
- Extension of this approach to create chemical sensors with integrated logic
- ✓ New principle of gas sensing
- ✓ Fast sensor recovery
- ✓ Application for fish freshness analysis