

Theory and Modeling of Eddy Current Type Inductive Conductivity Sensors

Julius Harms^{1,*}, Thorsten A. Kern¹

¹Institute for Mechatronics in Mechanics, Hamburg University of Technology; imek@tuhh.de

*Correspondence: julius.harms@tuhh.de

Abstract: While transformer-type conductivity sensors are the usual type of inductive sensors, this paper describes the theory behind less used eddy current sensors. This type of sensor measures conductivity of a liquid by inducing eddy currents and observing the effect on the sensor coil, which allows a simpler sensor design and promises a cost advantage in implementation. A novel model description is derived from the Maxwell equations and implemented by an equivalent RLC circuit. The designed model is validated by comparisons with experimental observations and FEM simulations. The result leads to a better understanding of the physical effects of the sensor and the influencing parameters for future sensor developments. The aim is to provide starting points for further sensor development of low-cost inductive conductivity sensors.

Keywords: Salinity; Conductivity; Inductive; Eddy Current; Sensor; Model;

1. Introduction

The functionality of an eddy current type conductivity sensor can be described by:

- Excitation coil generates magnetic flux in fluid
- Thereby eddy currents are induced into fluid
- Conductivity change measured by coil impedance change or second sensing coil

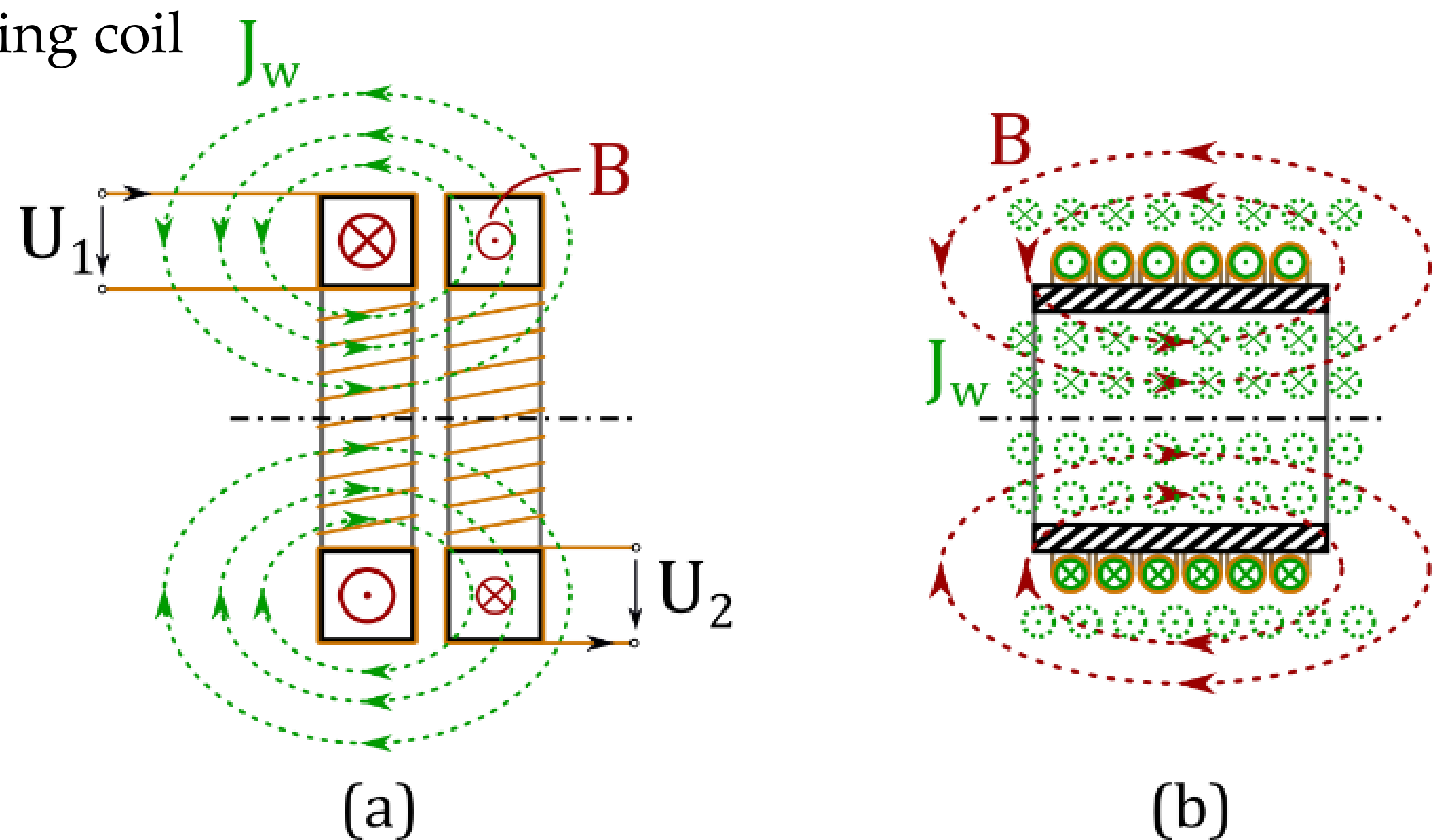

Figure 1: J- and B-Field illustration for (a) Transformer Type Sensor vs. (b) Eddy Current Type Sensor

2. Eddy Current Sensor Model

The transfer function (TF) model of the eddy current type sensor, is derived by using Maxwell's Equations to calculate the eddy current effect on the coils main magnetic field:

$$B = \frac{i \cdot w}{A \cdot R_{mag}} - \mu_0 \cdot \left(\sigma \cdot \frac{\delta B}{\delta t} + \epsilon_0 \cdot \frac{\delta^2 B}{\delta t^2} \right)$$

$$\Rightarrow \phi = \frac{i \cdot w}{R_{mag}(1 + \mu_0 \cdot \sigma \cdot s + \mu_0 \epsilon_0 \cdot s^2)}$$

This results into an extended impedance Z for the coil:

$$Z = \frac{L \cdot s}{1 + \mu_0 \cdot \sigma \cdot s + \mu_0 \cdot \epsilon_0 \cdot s^2}$$

Which can be modeled by a parallel R,L,C circuit where:

$$R_E = \frac{L}{\mu_0 \cdot \sigma} \text{ and } C_E = \frac{\mu_0 \cdot \epsilon_0}{L}$$

This non-parameterized derivation is a general consideration of coil impedance, taking into account eddy current effects. It can be used to model a single coil (Fig. 2a) or a two coil Sensor (Fig 2b) in a conductive fluid.

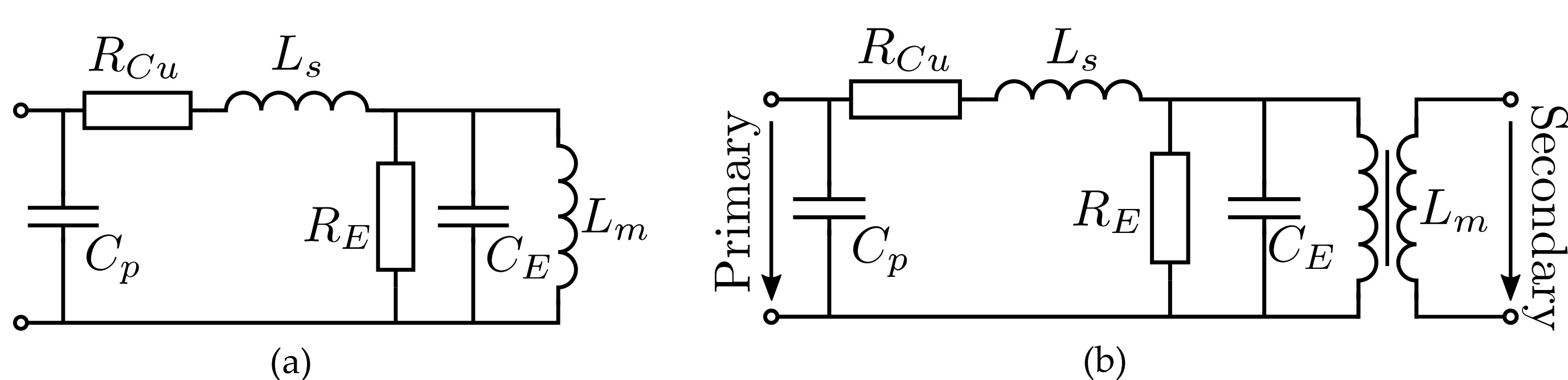

Figure 2: Equivalent circuit of (a) a single coil and (b) a coil pairing in conductive fluid, modeling the eddy current effect

3. Test and Simulation Results

For the model validation, an eddy current sensor is designed (Fig 3a) and implemented as a prototype (Fig 3b) and in an FEM-Simulation (Fig 3c).

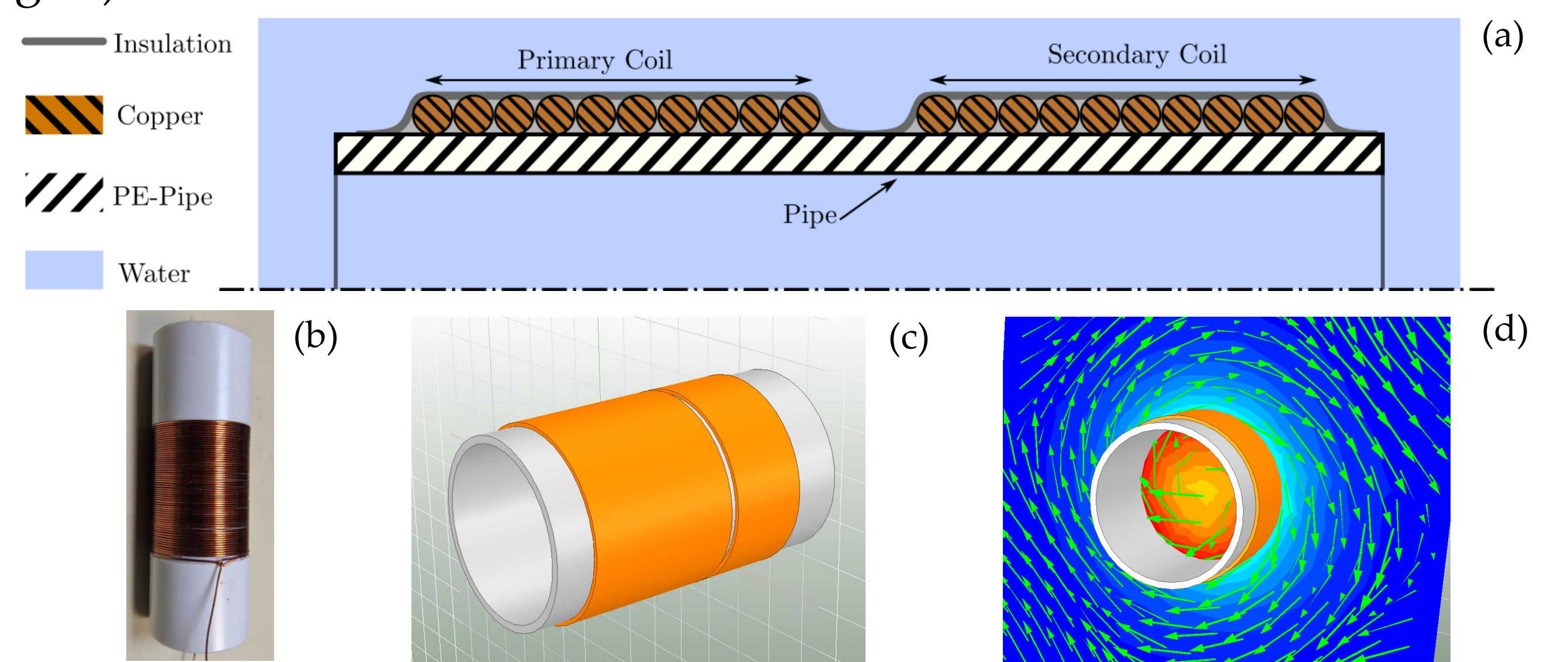

Figure 3: a) Schematic of the implemented eddy current sensor; b) Coil of prototype implementation; (c) 3D Model for FEM-Simulation; (d) Eddy Current visualization

The frequency response of the sensor prototype was measured for three different water conductivities and compared to the simulation of the RLC-model and the FEM model. Since the TF is not parameterized, the results were normalized to the resonance frequency.

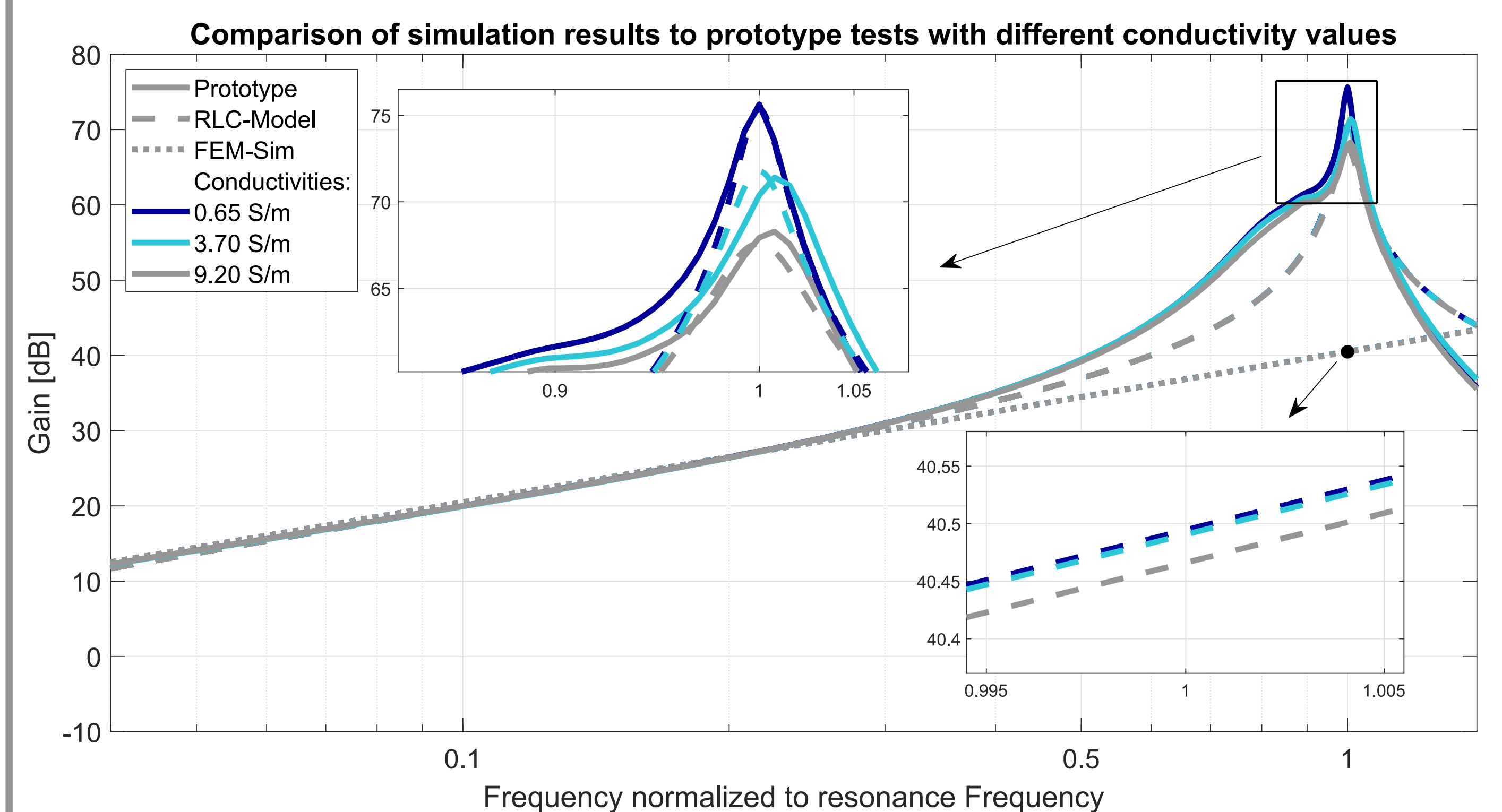

Figure 4: Comparison of simulation results to prototype tests with different conductivity values

4. Discussion & Conclusion

The results show that the here derived equivalent model can represent the eddy current effect for this sensor type. The theory of the ongoing effects was confirmed by practical tests and FEM-Simulations. An improved parameterization of the model is necessary to ensure a representative simulation.

The outcome of this paper gives a better model understanding of the eddy current sensor type which can lead to the design of optimized sensors. Based on the here derived results further development and investigation needs to be done to fully evaluate the potential and usage of eddy current sensors as an alternative to transformer type sensors.