



# The 3D-Printed Low-Cost Delta Robot *Óscar*: Technology Overview and Benchmarking

César M. A. Vasques <sup>1</sup> and Fernando A. V. Figueiredo <sup>2,3</sup>

<sup>1</sup> proMetheus, Escola Superior de Tecnologia e Gestão, Instituto Politécnico de Viana do Castelo, Rua Escola Industrial e Comercial de Nun' Álvares, 4900-347, Viana do Castelo, Portugal; cmavasques@gmail.com.

<sup>2</sup> Smile.Tech - Robótica, Vila Nova de Gaia, Portugal; ff@smlt.pt.

<sup>3</sup> Instituto Superior Politécnico Gaya (ISPGaya), Vila Nova de Gaia, Portugal.

**Abstract:** Robotics is undoubtedly one of the most influential fields of modern technology in changing the very nature of our society. Parallel Delta robots have for a long time been mainly focused on a niche market but compared to serial anthropomorphic robots they present several simplicity and improved dynamics features. Additive manufacturing (AM) and 3D-printing technologies are enabling rapid changes in robotic engineering as we classically know it, allowing for greater creativity and freedom in mechatronics design and innovation. The effective benefits of far-reaching design freedom in terms of geometry, materials, and manufacturing accessibility, are now starting to become apparent, answering many complex technical questions and scientific uncertainties that go beyond basic design and functional knowledge and that require engineering skills and scientific analysis. The Delta robot, as one of the most significant industrialized parallel robots due to its simplicity, is considered in this work, which provides an overview of the multidisciplinary aspects of the new Smile.Tech's 3D-printed and low-cost Delta robot *Oscar* family. It contains a concise analysis of the current state of the art and use of Delta robots, as well as discussion of the Delta architecture, interface software, and virtual operation environments. The article concludes with a market analysis, a summary of the major manufacturers and currently available Delta models, and a benchmarking study of their major operating and technical features.



**Citation:** The 3D-Printed Low-Cost Delta Robot *Óscar*: Technology Overview and Benchmarking.

*Proceedings* **2021**, *1*, 0.

<https://doi.org/>

Received:

Accepted:

Published:

**Publisher's Note:** MDPI stays neutral with regard to jurisdictional claims in published maps and institutional affiliations.



**Copyright:** © 2020 by the authors. Licensee MDPI, Basel, Switzerland. This article is an open access article distributed under the terms and conditions of the Creative Commons Attribution (CC BY) license (<https://creativecommons.org/licenses/by/4.0/>).

**Keywords:** Robotics; Delta; *Robótica* platform; *Óscar*; 3D-printing; low-cost; benchmarking.

## 1. Introduction

Recent advancements in artificial intelligence and 5G telecommunications services have resulted in robotic technology influencing an increasing number of aspects of our lives at work and at home. As a result of easy access to robots and the increasingly compelling interaction between robots and humans, our daily routines and work practices are being changed and automated in a secure manner, fostering research and dissemination of cutting-edge robotic technology and collaborative working environments.

The so-called *Delta robot* is a type of parallel robot whose fundamental concept is based on parallelograms (Figure 1). A parallelogram enables a fixed orientation of an output link relative to an input link. By employing three such parallelograms, the orientation of the mobile platform is completely constrained, leaving only 3 purely translational degrees of freedom. The 3 parallelograms' input links are mounted on rotating levers via revolute joints, which can be actuated in two ways: by rotational servomotors (DC or AC) or by linear actuators; the former being the most frequent. The servomotor enables exact control of an object's angular or linear position, velocity, or acceleration. It is composed of a suitable motor linked to a position sensor. Additionally, a rather sophisticated controller is required, frequently a dedicated module created exclusively for use with servomotors. Although the term servomotor does not relate to a specific type of motor, it is frequently used to refer to a motor that is appropriate for use in a closed-loop control system. Finally,

a fourth leg may be used to transmit rotary motion from the base to the mobile platform's end-effector. According to [3] the mobile platform's (element 8 in the left in Figure 1) use of base-mounted actuators and light-weight links enables accelerations of up to 50g in experimental environments and 12g in industrial applications. As a result, the Delta robot is ideal for pick and place operations involving light objects (from 10 grams to 1 kg). Its workspace should ideally be the intersection of three right circular tori. Delta robots on the market typically operate in a cylindrical workspace with 1 m diameter and 0.2 m height.

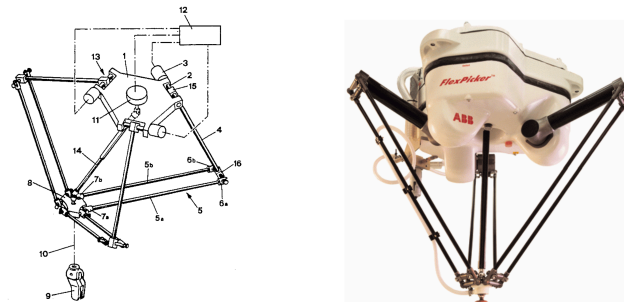

**Figure 1.** Schematic of the original Clavel's Delta robot patented in 1990 [4] and first ABB Flexible Automation's Delta robot IRB 340 FlexPicker launched in 1999.

The Delta robot, as one of the most significant industrialized parallel robots due to its simplicity, is considered in this work, which provides an overview of the multidisciplinary aspects of the new Smile.Tech's 3D-printed and low-cost Delta robot, the *Óscar* family. It addresses a concise and overview analysis of the current state of the art and use of Delta robots, as well as discussion of the Delta architecture, interface software, and virtual operation environments. The article concludes with a market analysis, a summary of the major manufacturers and currently available Delta models, and a benchmarking study of their major technical and operating features. Due to space limitations only the most relevant aspects are revealed here.

## 2. The *Óscar* Delta Robot Family Development

Automated systems have become more prevalent in recent years in smaller and smaller businesses, offices, schools, and households, owing to the advent of mass production, 3D printing, and open source solutions. It's relatively easy to find examples of this in any field. Automated software completion, scheduled reminders on our agenda, automated data collection and dashboard generation for company executives, self-driving vehicles, automated access control, and even automated vacuum cleaning and kitchen robots are all possible. While the statements above are accurate, despite their exponential growth in industrial settings, non-cartesian robotic manipulators have not yet been widely adopted. Our assessment indicates that there are three significant impediments maintaining the existing state of affairs:

1. A good match between arm length and payload results in a high moment of inertia, which makes direct drive actuators extremely heavy and economically inefficient. With the addition of a reduction system to the output shaft, smaller actuators may be used and, in this case, any backlash results in a significant positioning error; although backlash-free reducers are commercially available, they are quite expensive.
2. Safety! Long arms necessitate the use of powerful actuators. When these machines are operating in close proximity to humans, they must protect the latter in the event of contact. As a result, it is necessary to distinguish between the torques required to maneuver a payload and the torques generated by a collision, which is not always easy to do with proven guaranteed success.

- Ease of use; the average user does not anticipate that its operation will require minimal and rapid configuration, without the need for special training, or that the system will operate autonomously to a greater degree.

With the above in mind, the iterative design procedure for the Oscar Delta robot included many stages and a long time since its first version was set back in 2016 (see Figure 2). The market for collaborative robotics applications is widely perceived to be developing to satisfy the demands of consumers or clients across a varied variety of sectors and applications with varying specifications. This was also discovered through market research and the company’s expertise identifying the demands of future consumers, indicating that expanding into a library of off-the-shelf integrating parts and family of Delta solutions was the way to go. The first step in developing the design was to ascertain the true nature of the problem, which was accomplished through analysis. This is a critical stage because incorrectly defining the problem can result in time being wasted on designs that do not meet the requirement. Following the analysis, it was possible to create and document a specification of the requirements, with some of the primary requirements being an excellent cost-performance ratio and safety suitability for collaborative and effective broad-scope use. Various concepts were developed throughout the conceptual stage, followed by preliminary engineering analyses of the most promising solutions, as illustrated in Figure 2.

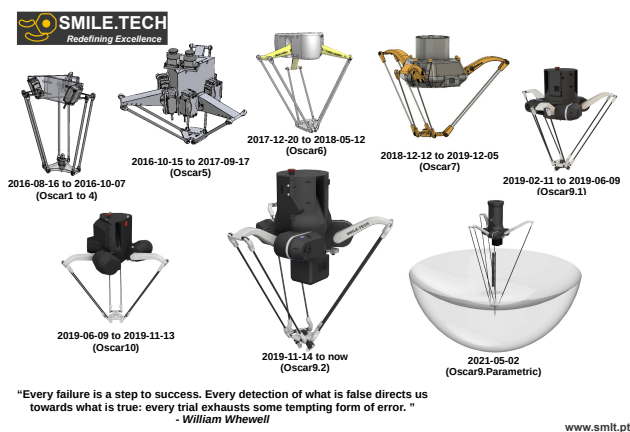

**Figure 2.** History of the iterative design, successive Delta-robot model versions and Óscar family.

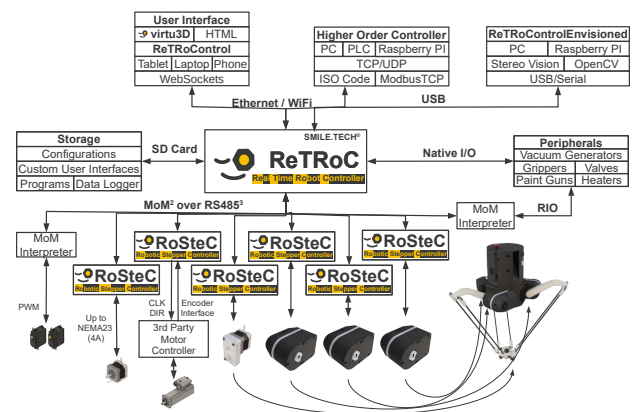

**Figure 3.** Overview of the Smile.Tech’s SMLT Robótica Platform (STRP) and product breakdown structure.

Outline solutions were developed and detailed enough to indicate the methods for achieving each of the required functions, e.g. approximate sizes, shapes, materials, costs, and performance (whether by test or analysis). Additionally, it entails determining what has been done previously to address similar issues; there is no point in reinventing the wheel and subsequent versions have been built upon previous knowledge about the former versions. The various solutions were weighed and the most appropriate ones were chosen. Oftentimes, evaluation involved modeling the system and then simulating it to determine how it might react to various inputs and selecting the most suitable solution. The details of the chosen design have now been worked out, including the creation of prototypes or mock-ups based on 3D printing of selected components in order to ascertain the optimal design details. The chosen designs were then translated into working drawings, circuit diagrams, and so on, so that the items can be promptly manufactured and dispatched as part of a continuous technology improvement process and market entrance.

### 3. The Smile.Tech’s SMLT Robótica Platform

The Smile.Tech’s SMLT Robótica Platform (STRP) is an in-house dedicated cost-effective robotic platform that outperforms competitors in terms of efficiency, accuracy, reliability, and safety. It makes use of stepper motors due to their simplicity of position control and, more significantly, their simplicity of velocity restriction. These motors are connected

to low-backlash mechanical reducers that incorporate absolute position feedback on the output shaft. The torque created by this assembly can be simply computed from its elastic deformation, allowing the system to calculate the magnitude and direction of force at all times. As depicted in Figure 3, the platform is composed of multiple components connected in a variety of ways. The PDR-20 (resorting of the Óscar 9 model) is a delta robot that is built upon the STRP and comprises 4 major key components, where these key components can be arranged to build any kind of manipulation robot kinematics:

- Programming and simulation software (Virtu3D, ReTRoControl and ReTroControlEnvisioned);
- A Real Time Robot Controller (ReTRoC);
- A Robotic Stepper Controller (RoSteC);
- A Belt Elastic Actuator for Robotics (BEAR).

The STRP is a comprehensive system built on three interconnected pillars: the BEAR, the ReTRoC and the Virtu3D (Figure 4). By substituting elasticity for backlash in the transmission, the BEAR eliminates positioning uncertainty and provides mechanical compliance. It is a low-cost actuator based on the popular NEMA 17 stepper motor series. It includes instrumentation and a controller called RoSteC which calculates torque based on transmission deformation and is capable of compensating for, or virtually increasing compliance. All robotic actuators (BEARs) are connected via an RS485 communication network and are managed by the ReTRoC. This controller is capable of interpreting commands sent by higher-order controllers or pre-programmed sequences stored on an SD card. Additionally, it manages motion and trajectory, converts coordinates, and calculates forces and their directions using data from the actuators’ torque sensors. Lastly, Virtu3D is an online tool that works on any computer, tablet, or smart-phone, that can be used to program and simulate robotic systems and that is capable of connecting to the robot controller via Ethernet or WiFi.

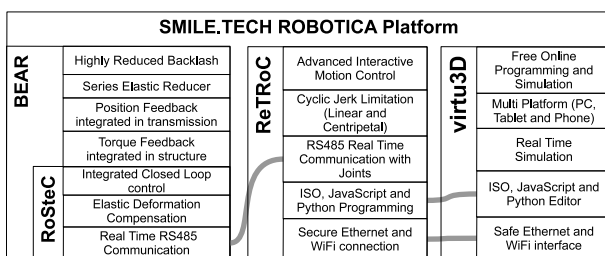

Figure 4. Components of the Smile.Tech’s SMLT Robótica Platform (STRP) feature diagram.

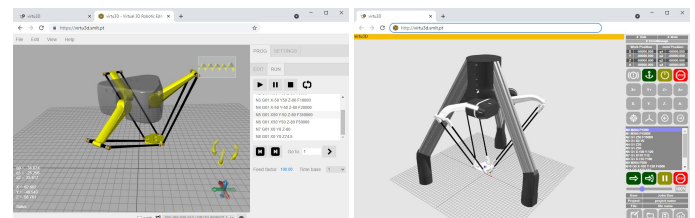

Figure 5. Virtu3D, a web-based application that can be used on any computer, tablet, or smartphone to program and simulate robotic systems and is capable of connecting to the robot controller via Ethernet or WiFi; on-line kinematics simulation version at <https://virtu3d.smlt.pt>; initial (left) and current (right) versions.

#### 4. Market, Manufacturers and Benchmarking

These days, the robotics industry mainly serves two distinct markets – industrial and professional services – commonly lumped together. The emergence of new service robots has been noticed by many organizations throughout the world and steps have been taken to support the new developments [5]. However, industrial robots and professional service robots have different operational requirements, different cost and have recently shown to have very different market growth rates [6]. Industrial robots have been around since the 1970s, the archetypal industrial robot being the mechanical anthropomorphic arm with varying levels of degrees of freedom and flexibility found in factories around the world. In manufacturing industry the biggest users of industrial robots by descending order are in general the automotive, electrical/electronics, metal and machinery, plastics and chemicals, and food and beverage sectors. In contrast to industrial robots, professional service robots are more recent, really taking off within the last decade, and are typically used outside of manufacturing lines to assist humans rather than replacing them. They can have wheels

to make them mobile, some are anthropomorphic, but they are not intended for the kinds of heavy tasks that most industrial robots tackle. Thus far, professional service robots have been most popular in the retail, hospitality, health care and logistics (in warehouse or fulfillment settings) industries, although some have also started to be used in space and defense, agriculture, and demolition. In addition to the industrial and professional service robots used by enterprises, there are two other large and quickly growing consumer robot markets – consumer service and entertainment robots; the former designed for tasks such as vacuuming, mowing the lawn and washing windows; and the latter consisting mainly of toys, some of which fairly sophisticated, mainly made in Asia.

The foregoing analysis is detailed in a recent market study [7], pointing out that nearly 1 million robots were expected to be sold for enterprise use in 2020, where over half of them were expected to be professional service robots, generating more than \$16 billion in revenue, 30% more than in 2019. Also, the market for professional service robots is growing much faster than that for industrial robots, where professional service robots are on the verge of passing industrial robots in terms of units and revenue. On the other hand, although 97% of all of the robots sold in 2019 were consumer service and toy robots, they represent only 14% of robotics industry revenue, where industrial robots lead with 49% of revenues; but the growth drivers of 5G, artificial intelligence chips and affordability of robotic technology are also likely to have a strong influence on consumer robots growth in the future and certainly contribute to a rapid market change. Regarding collaborative robots, another study [8] points out that the market size is expected to reach a value of \$ 1.09 billion, at a compound annual growth rate (CAGR) of 16.08% with accelerating momentum, during 2021-2025; 34% of the growth will originate from the Asia-Pacific region and key countries are presently US, China and Germany. Refer also to [9] for a recent tracing of the evolution of service robotics.

For the Delta's, still another market study [10] predicts that the global delta robots market size will grow by \$242 million during 2019-2023 with a CAGR of almost 9%, also accelerating, with 50% coming from the Asia-Pacific region; in a fairly fragmented market, where one of the key trends for the period is the development of vision-integrated Delta robots, bringing up new application possibilities. Delta robots are reported to have been typically designed and optimized to meet the requirements of extremely fast product handling, low cost, and easy disassembly for cleaning in the food (e.g. dough cutting or pancake stacking) and packaging industries (e.g. top-loading, feed placement, and assortment placement). Additionally, the medical field, the electronics industry, pick-and-place tasks for cells and wafers in the photovoltaic industry, laser cutting, high-speed milling, drilling, wood tooling, and use as a 3D haptic device with force feedback in the gaming industry are possible applications highlights. Additionally, agricultural applications have been reported beginning to include a Delta-based prototype for manipulating soft vegetables, an autonomous field robot platform equipped with a Delta robot for treating individual plants, and a non-chemical vegetable weed controller. See also [3,11] and the references therein for further details on Delta applications and an overview of the historical developments of the Delta robot on the market and academia.

According to [11,12], the license for the delta robot was purchased in 1987 from EPFL to a Swiss company, Demarex, which started the industrial development process and began manufacturing delta robots for the packaging industry at that time. In 1996, Demarex bought the license and merged with Sigpack Systems to increase competitiveness and internationalization to sell in the world market. The IRB340 FlexPicker delta robot was also launched in 1999 by ABB Flexible Automation that purchased also a license. Later in 2004 the merged Demarex and Sigpack Systems were incorporated by the Bosch Packaging Technology division. Since then, and fostered also by the expiration of the Clavel's original patent, parallel robots with Delta-like architecture have attracted the interest by industry and researchers all over the world. The global delta robot market has become moderately fragmented since then also due to the expiration of the original Clavel's patent and progressively others, with various manufacturers located all over the world. However, several

**Table 1:** Benchmarking of technical specifications of selected Delta robots in the same class of the PDR-20 of Smile.Tech’s *Óscar* family.

Model reference	Weight /kg	Workspace ( $r \times z$ ) /mm <sup>2</sup>	Payload /kg	Speed (max) /m·s <sup>-1</sup>	Accel. (max) /m·s <sup>-2</sup>	Power (drive) /W	DoF #	Repetition accuracy /μm	Price (reference) €
ABB IRB360-3/1130	120	565 × 250	3	10	150	477	4	±100	25,000
FANUC M-1iA/HL	18	210 × 150	1	N/A	N/A	200	3	±30	15,000
FESTO EXPT95	62	200 × 150	5	7	110	200	3	±100	20,000
IGUS DLE-DR-0003	15	150 × 75	3	3	60	200	3	±500	7,000
SMLT PDR-20	6	320 × 100	2	0.35	50	200	3	±30	5,000

N/A: Not available;  $r$  and  $z$ : radius and height of the cylindrical robot workspace envelope.

top-rated companies, such as ABB (Swedish–Swiss), FANUC (Japan), Kawasaki Heavy Industries (Japan), Adept/Omrom (USA/Japan), Yaskawa Electric (Japan), Codian Robotics (Netherlands), Penta Robotics (Netherlands), Estun Automation (China), and Bosch (Germany), are apparently leading the way. As such, Delta robots have nowadays popular usage in picking and packaging in factories because they can be quite fast, some executing up to 300 picks per minute. For its stiffness it is also used for surgery and other applications include high precision assembly operations in a clean room for electronic components. The structure of a Delta robot can also be used to create haptic controllers [13–15]. Agriculture apps [16] and others used in mechanical machining processes [17,18]. Surveys on parallel robots with Delta-like architecture can be found e.g. in [11,12].

A list of commercially available Delta-robots along with their main features is presented in table 1. As a benchmarking study, the features of the *Óscar9* SMLT Delta robot PDR-20 are also presented. The criteria for the benchmarking analysis was to select consolidated manufacturers and Delta models with a payload in the same range of the SMLT PRD-20, i.e., < 5 kg, and with a comparable architecture and number of DoF. As can be seen, the prices and weight differ significantly at the cost of sacrificing speed, for equivalent (or, at least, not significant for the majority of applications) position accuracy. The top two models represent two consolidated and high-performance models from ABB and FANUC; the middle model is an unusually featured model from Festo; and the fourth model is the most comparable model from Igus, targeted at a similar clientele as the SMLT PDR-20. Together, they provide a streamlined overview of the market and competing products, allowing for accurate and concise benchmarking and selection. The SMLT PDR-20 in the *Óscar9* version, whose features were mainly determined by analysis of design and engineering judgment, is shown to be the most affordable one and to cover a range of operating requirements and cost benefit trade-off not yet fully covered by the most well-know models available in the market.

### 5. Conclusion

Commercial Delta and Delta-like robots serve a niche market for high-speed pick-and-place applications almost 40 years after the original ideas. Patents that have expired and new areas of application have resulted in an increase in research and development during the past decade. The growing scientific emphasis on extended architectures with more rotational DoF has resulted in a variety of serial-parallel hybrid and completely parallel systems. These ideas address industry requirements for new and more complex handling jobs with greater payload capacity and required uncontaminating designs.

This article describes the process and major technical developments and features of a platform for developing safe, easy-to-use, precise, and reliable robotic manipulators that are also affordable for general public use – the Smile.Tech’s *SMLT Robótica Platform* (STRP) and the family of the *SMTL Delta Robot Óscar*. The STRP project aims to leverage technologies that, despite their longevity, are not yet widely adopted. Two examples include additive manufacturing (AM) and substituting transmission elasticity by transmission backlash. Another significant feature of the STRP is that its success is determined not only by the achievement of the proposed technical features, but also by the acceptance and satisfaction

of its derived products by customers. Thus, during the design and integration processes we have covered all aspects of parallel robots, from their modeling (geometric, kinematic, dynamic, elasticity, etc.) to the advanced control, while taking also into account singularity analysis, calibration and model parameter identification problems, the definition of advanced algebraic tools necessary for their study, their optimal design, and a variety of other scientific and technology development needs. This study addresses a focused analysis of the current state of the art and use of Delta robots, as well as discussion of the Delta architecture, interface software, and virtual operation environments, and the technologies involved. Moreover, the article presents a market analysis, a summary of the major manufacturers and currently available Delta models, and a benchmarking study of their major operating and technical features. Overall, this work is expected to contribute to and enable a sustained selection and identification of the primary technical characteristics of leading Delta robots in the same class, as well as the advantages of the Smile.Tech's Delta robot model SMLT PDR-20 and its success in being an appellation to the collaborative robots market due to its affordable price, high level of safety, and exceptional cost-benefit ratio.

**Acknowledgments:** The first author gratefully acknowledges the support provided by the Foundation for Science and Technology (FCT) of Portugal, within the scope of the project of the Research Unit on Materials, Energy and Environment for Sustainability ([proMetheus](#)), Ref. UID/05975/2020, financed by national funds through the FCT/MCTES.

## References

1. Briot, S.; Bonev, I.A. Are parallel robots more accurate than serial robots? *Transactions of the Canadian Society for Mechanical Engineering* **2007**, *31*, 445–455. doi:10.1139/tcsme-2007-0032.
2. Pierrot, F.; Nabat, V.; Company, O.; Krut, S.; Poignet, P. Optimal design of a 4-DOF parallel manipulator: From academia to industry. *IEEE Transactions on Robotics* **2009**, *25*, 213–224. doi:10.1109/TRO.2008.2011412.
3. Bonev, I. Delta Parallel Robot – the Story of Success. Published online, <http://www.parallemic.org/Reviews/Review002.html>, 2001. Accessed: 2021-07-13.
4. Clavel, R. Device for the movement and positioning of an element in space, 1990. US Patent 4,976,582, Dec. 11.
5. Virk, G.S.; Moon, S.; Gelin, R. ISO Standards for Service Robots. *Advances in Mobile Robotics*, 2008, pp. 133–138. doi:10.1142/9789812835772\_0016.
6. Global Delta Robots Market. Market.us, <https://market.us/report/delta-robots-market>. Accessed: 2021-07-13.
7. Stewart, D.; Wigginton, C.; Casey, M., Robots on the move: Professional service robots set for double-digit growth. In *Deloitte Insights - Technology, Media, and Telecommunications Predictions 2020*; Deloitte Development LLC, 2019; pp. 18–29.
8. Collaborative Robots Market by Application and Geography - Forecast and Analysis 2021-2025. Technavio, <https://www.technavio.com/report/collaborative-robots-market-industry-analysis>. Accessed: 2021-07-17.
9. Ott, I.; Savin, I.; Konop, C. Tracing the evolution of service robotics: Insights from a topic modeling approach. *Kiel Institute for the World Economy (IfW)* **2021**, *Kiel Working Paper no. 2180*, 47.
10. Global Delta Robots Market 2019-2023. Technavio, <https://www.technavio.com/report/global-delta-robots-market-industry-analysis>. Accessed: 2021-07-17.
11. Brinker, J.; Corves, B. A survey on parallel robots with Delta-like architecture **2015**. pp. 407–414. doi:10.6567/IFToMM.14TH.WC.PS13.003.
12. Poppeova, V.; Uricek, J.; Bulej, V.; Sindler, P. Delta robots - Robots for high speed manipulation. *Tehnicki Vjesnik-Technical Gazette* **2011**, *18*, 435–445.
13. Grange, S.; Conti, F.; Helmer, P.; Rouiller, P.; Baur, C. Delta haptic device as a nanomanipulator. *Microrobotics and Microassembly III*; Nelson, B.J.; Breguet, J.M., Eds. SPIE, 2001. doi:10.1117/12.444117.
14. Mitsantisuk, C.; Ohishi, K. Haptic human-robot collaboration system based on delta robot with gravity compensation. *IECON 2016 - 42nd Annual Conference of the IEEE Industrial Electronics Society*. IEEE, 2016. doi:10.1109/iecon.2016.7793735.
15. Liu, G.; Chen, Y.; Xie, Z.; Geng, X. GA\SQP optimization for the dimensional synthesis of a delta mechanism based haptic device design. *Robotics and Computer-Integrated Manufacturing* **2018**, *51*, 73–84. doi:10.1016/j.rcim.2017.11.019.
16. Hussmann, S.; Knoll, F.J.; Meissner, A.; Holtorf, T. Development and evaluation of a low-cost delta robot system for weed control applications in organic farming. 2019 IEEE International Instrumentation and Measurement Technology Conference (I2MTC). IEEE, 2019. doi:10.1109/i2mtc.2019.8826959.
17. Ayyıldız, E.A.; Ayyıldız, M. Development of a 3-axis Parallel Kinematic Machine for Milling Wood Material – Part 1: Design. *Bioresources* **2017**, *12*, 9326–9337.
18. Ayyıldız, E.A.; Ayyıldız, M.; Kara, F. Optimization of surface roughness in drilling medium-density fiberboard with a parallel robot. *Advances in Materials Science and Engineering* **2021**, *2021*, 1–8. doi:10.1155/2021/6658968.