

# A Critical View on the Partial Discharge Models for Various Electrical Machines' Insulation Materials



**D. Verginadis<sup>1\*</sup>, T. Iakovidis<sup>1</sup>, A. Karlis<sup>1</sup>, M. G. Danikas<sup>1</sup>**

*Department of Electrical and Computer Engineering, Democritus University of Thrace, Xanthi, Greece*

**J. Antonino-Daviu<sup>2</sup>**

*Department of Electrical Engineering, Universitat Politècnica de València, Valencia, Spain*



---

THE 1ST INTERNATIONAL ELECTRONIC CONFERENCE ON  
MACHINES AND APPLICATIONS

SESSION: MACHINES TESTING AND MAINTENANCE

IECMA  
2022

# Outline of the Presentation

---

- Introduction
- PDs on EMs
- PD Models
  - Capacitive Model
  - Capacitive-Resistance Models
- Simulations – Results
- Discussion
- Conclusions

# Introduction (1/2)

---

- Electrical Machines (EMs) and especially Synchronous Generators (SGs) play a vital role in energy production and in Industry.
- Reliable, proper operation and maximum performance with the minimum maintenance are the qualities that should characterize an EM used in industry.
- The component that plays the most significant role on the aforementioned characteristics is SG's insulation system, which, most of the times, consists of a combination of Epoxy Resin (ER) and mica.

# Introduction (2/2)

---

- ER is characterized by:
  - high mechanical strength and chemical resistance
  - good physical and electrical properties
  - resistance to moisture and radiation.
- Mica has:
  - low dielectric losses,
  - good mechanical resistance, dielectric constant and thermal conductivity.
- The combination of these two insulation materials creates very good insulation properties for SGs.

# Partial Discharges on Electrical Machines (1/2)

---

- Partial Discharges (PDs) are electrical discharges, which partially bridge the insulation between conductors and they are both a symptom and a mechanism of insulation aging.
- PDs are one of the most dangerous factors for contamination and degradation of the EMs' insulation system.
- PDs are both a symptom of insulation degradation and a way to investigate what is the condition of the EMs' insulation system.
- PD measurement (offline on online) on EMs (IEC 60034-27) uses coupling capacitors at the EM terminals and monitors the high frequency currents that flow through these capacitors.

# Partial Discharges on Electrical Machines (2/2)

---

- Following figures were taken by a borescope inside a real SG's stator and traces of PDs, serious damage and general insulation degradation are evident.



Visual Inspection 2009



Visual Inspection 2010

# Simulation of PD Models

- Simulations were made with:
  - The test object of the figure
  - Three different applied voltages (5 kV, 10 kV and 15 kV)
  - Double radius and double height of the cylindrical void.
- Three different insulation materials:
  - Epoxy Resin (Relative Permittivity = 3.6)
  - Mica (Relative Permittivity = 5)
  - Combination of these two insulation materials (Relative Permittivity is calculated by the following formula)

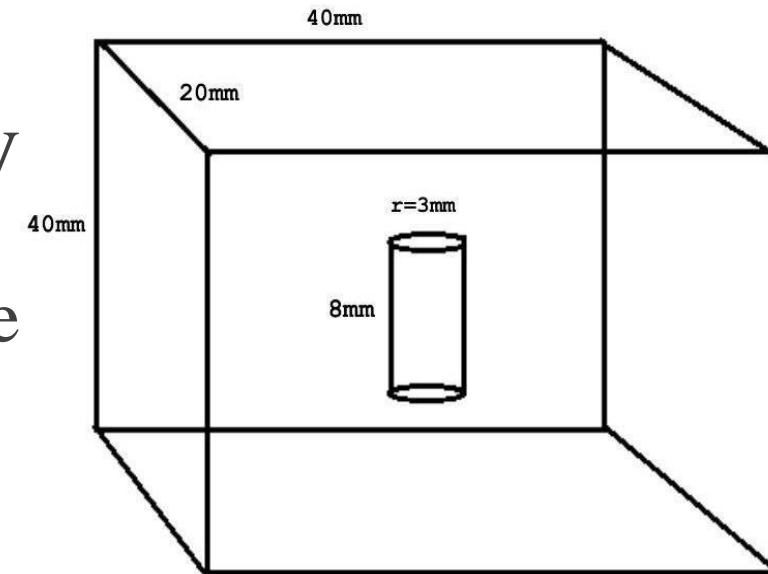

# Combination of ER-Mica

---

$$e_{r3} = \frac{e_{r1}e_{r2}(s_1 + s_2)}{e_{r1}s_2 + e_{r2}s_1}$$

where  $e_{r1}$  is the relative permittivity of mica,  $e_{r2}$  is the relative permittivity of 28 ER,  $s_1$  is the width of mica and  $s_2$  is the width of ER.

ER and mica were supposed to cover the same volume of the test object.

The relative permittivity of the combination of these two insulation materials was calculated  $e_{r3}=4.12$ .



# Capacitive Model (1/4)

- AC High Voltage (HV) Source,
- Resistor ( $R$ ), which acts as a HV filter in order to reduce the noise of the source,
- HV Measuring Capacitor ( $C_m=1000\text{ pF}$ ) and Coupling Capacitor ( $C_k=8\ 1000\ \mu\text{F}$ ), which are used in order to capture the displacement current created during PD,
- Measuring Impedance (MI) RLC ( $R_m=50\ \Omega$ ,  $C_m=0.45\ \mu\text{F}$  and  $L_m=0.60\ \text{mH}$ ) in order to collect PD signals and
- Three Capacitors ( $C_a$ ,  $C_b$ ,  $C_c$ ), whose values depend on the insulation material

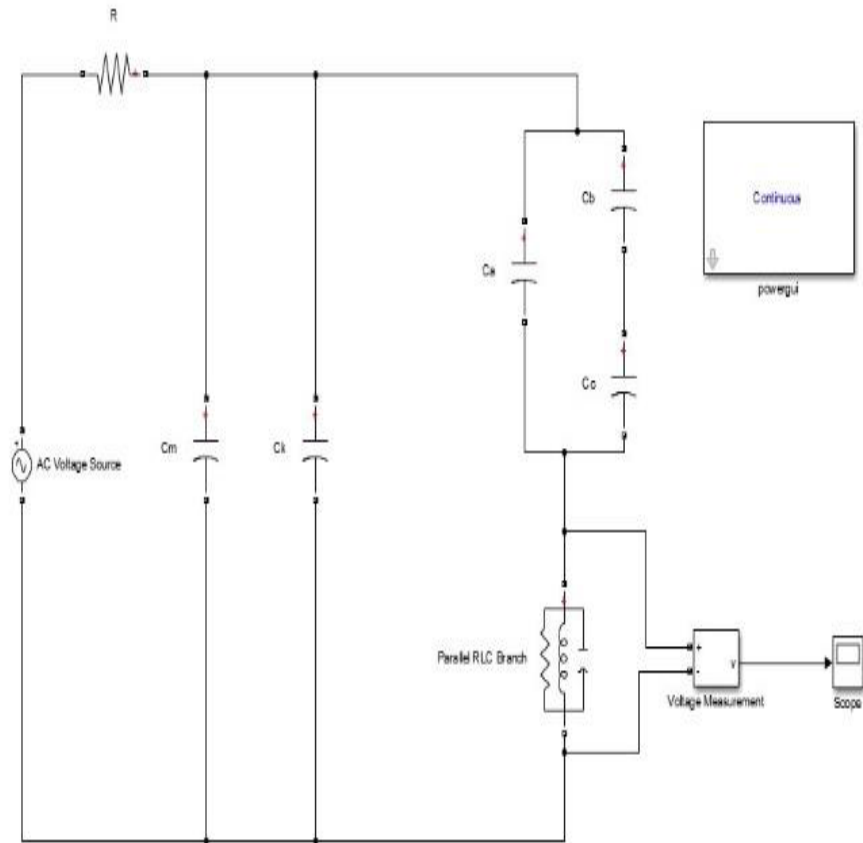

## Capacitive Model (2/4)

---

$$C_a = \frac{\epsilon_0 \epsilon_r (a - 2r) b}{d}$$

$$C_b = \frac{\epsilon_0 \epsilon_r r^2 \pi}{d - h}$$

$$C_c = \frac{\epsilon_0 r^2 \pi}{h}$$

where  $\epsilon_0$  is the dielectric constant in vacuum,  $\epsilon_r$  is the relative permittivity (dielectric constant) of the insulating material,  $a$  is the length,  $b$  is the width and  $d$  is the height of the test object,  $r$  is the radius, and  $h$  is the height of the void. It must be noted that  $C_c$  is the capacitance of the void in the solid material,  $C_b$  is the capacitance of the insulation material connected to the void and  $C_a$  is the capacitance of the remaining insulation.

# Capacitive Model (3/4)

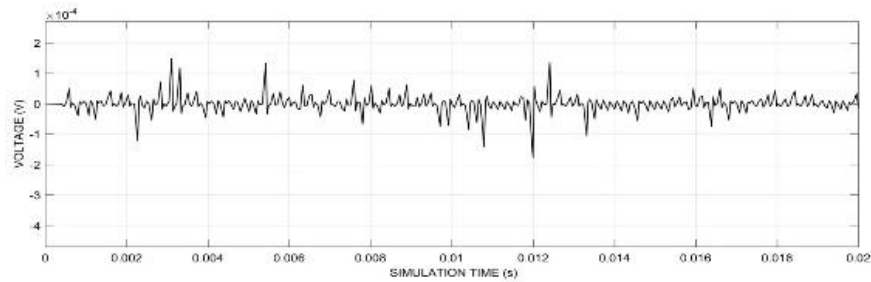

PD Activity -  
ER (a) 5 kV,  
(b) 5 kV -  
double  
radius.

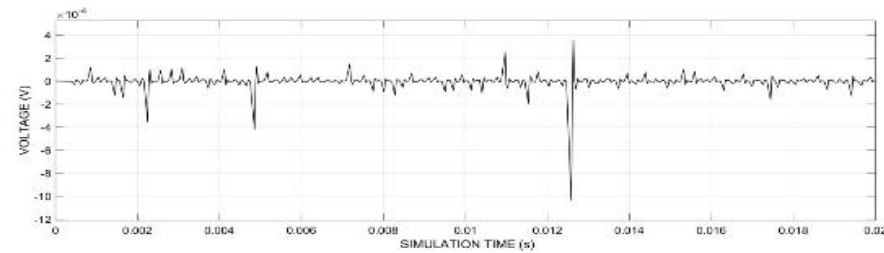
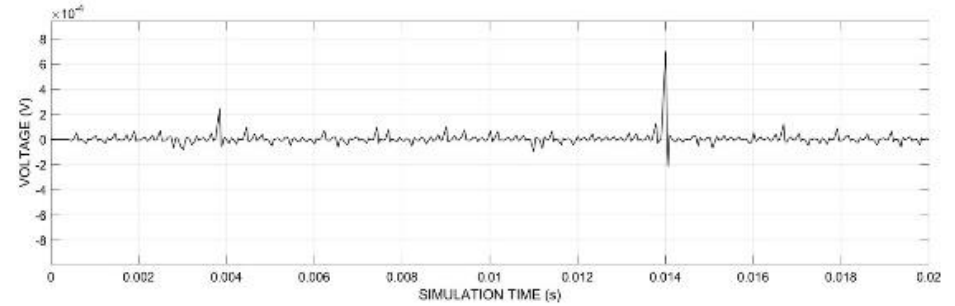

PD Activity -  
Mica (a) 10 kV,  
(b) 10 kV -  
double height.

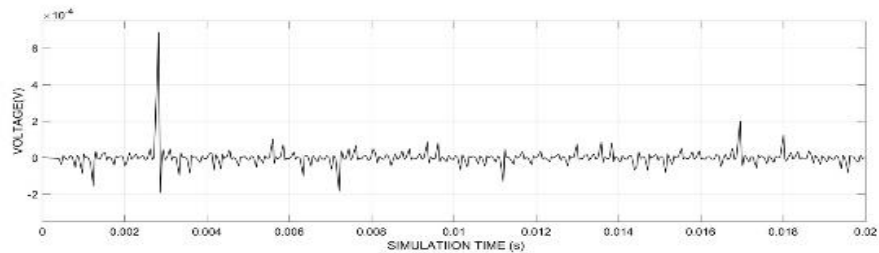
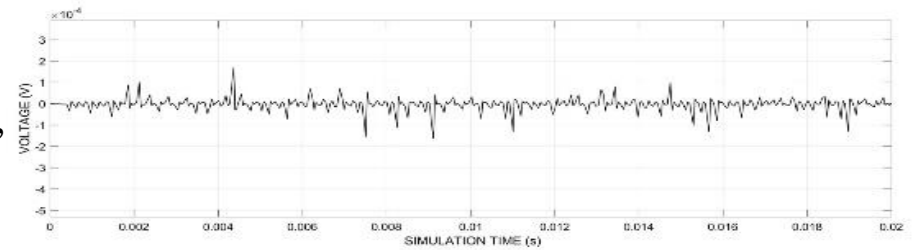

PD Activity -  
Combination (a)  
15 kV, (b) 15 kV  
- double radius.

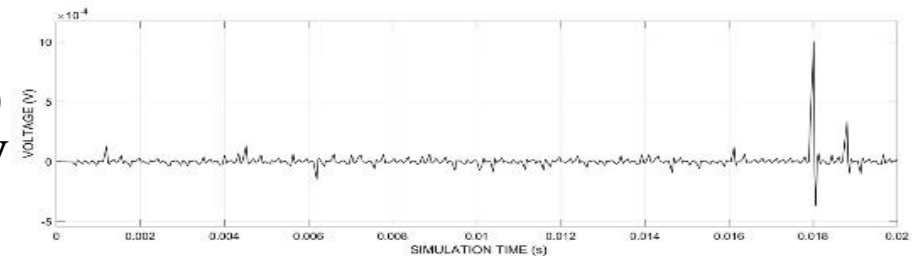

# Capacitive Model (4/4)

---

- It is obvious in all figures that when the applied voltage increases, the number of PDs increases.
- When the geometry of the void increases, the PD activity increases.
- Mica seems to present more PDs and smaller maximum PD amplitude compared to the two other insulation materials.
- ER has shown the fewest number of PDs.
- The combination of the two materials seems to present the lowest number of PDs.

# Capacitive-Resistance Model (1/4)

- This PD model is an advanced capacitive model, because resistors were placed opposite the three capacitors.
- The three resistors indicate the resistance of the insulation material and were added in order to have a more detailed representation of the insulation material, because geometric dimensions, relative permeability and specific volumetric resistance are taking into account.

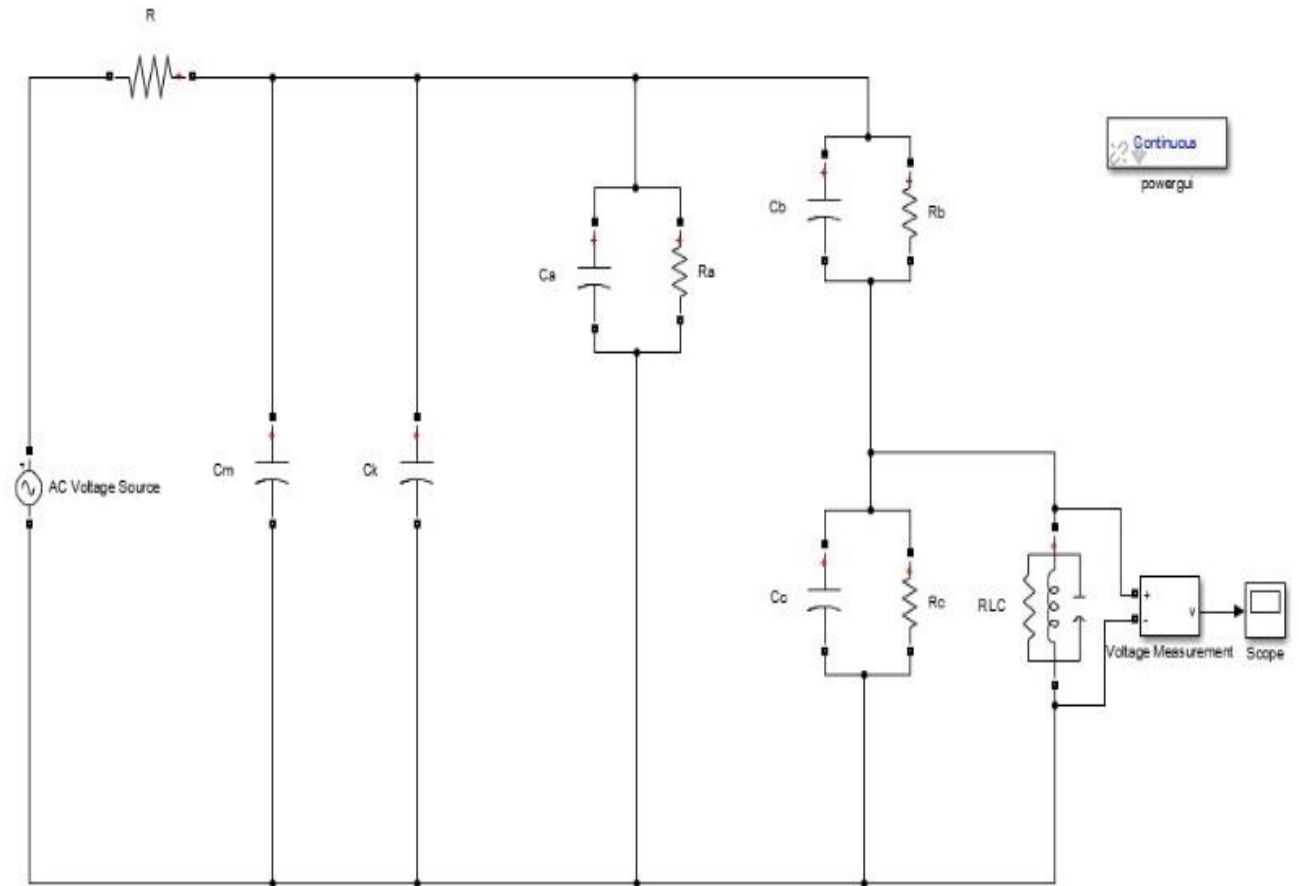

# Capacitive-Resistance Model (2/4)

---

- The three resistances are calculated by:

$$R_a = \frac{\rho_{ins} h}{ab - \pi r^2}$$

where  $\rho_{ins}$  is the electrical resistivity of solid insulation ( $10^{15} \Omega m$ ) and  $\rho_{cav}$  is the electrical resistivity of the air cavity ( $10^{15} \Omega m$ ).

$$R_b = \frac{\rho_{ins}(h - h_{cav})}{\pi r^2}$$

$$R_c = \frac{\rho_{cav} h_{cav}}{\pi r^2}$$

# Capacitive-Resistance Model (3/4)

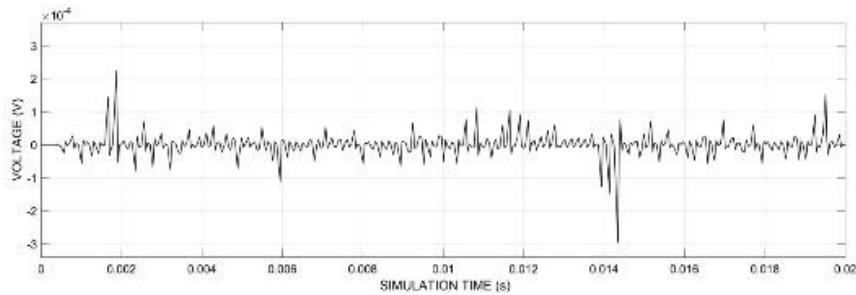

PD Activity -  
ER **(a)** 5 kV,  
**(b)** 5 kV -  
double  
radius.

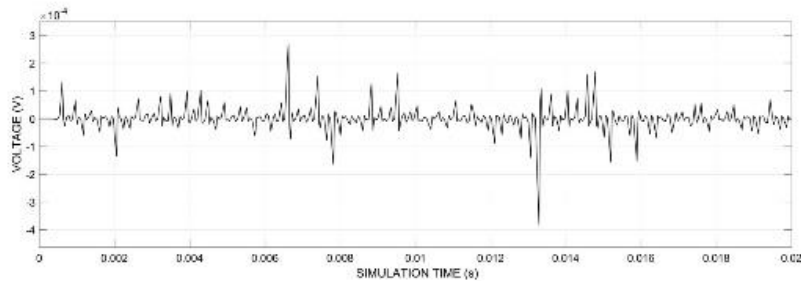
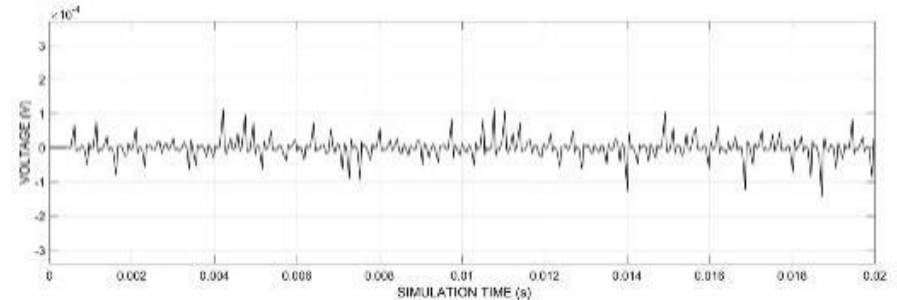

PD Activity -  
Mica **(a)** 10 kV,  
**(b)** 10 kV -  
double height.

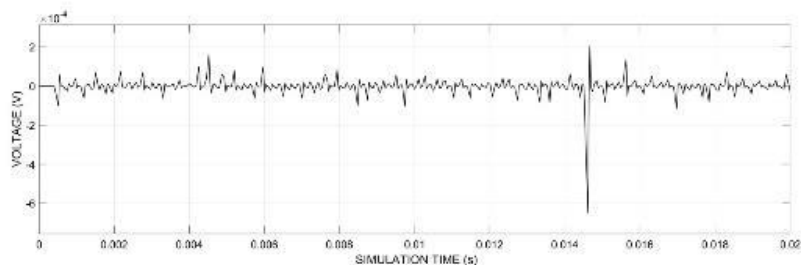
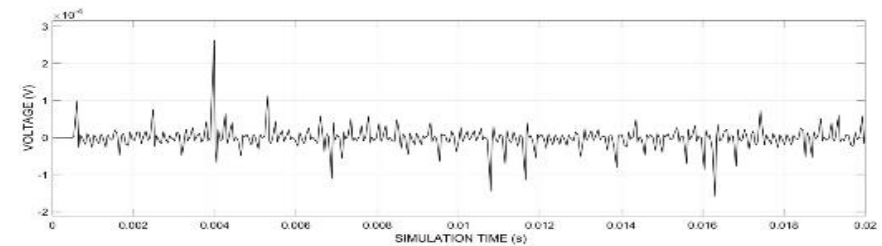

PD Activity -  
Combination **(a)**  
15 kV, **(b)** 15 kV  
- double radius.

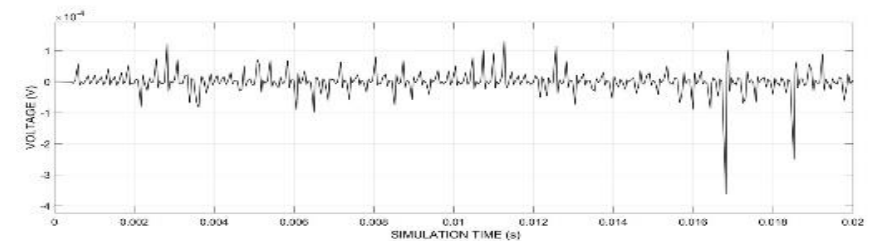

# Capacitive-Resistance Model (4/4)

---

- The increase of the applied voltage leads to the increase of the PD activity.
- The diagrams with double radius or/and double height, show that when the volume of the void increases, the number of PDs increases.
- The combination of the two materials seems to achieve the best results
- ER presents the fewest number of PDs.
- Mica the smaller maximum PD amplitude.



# Discussion (1/2)

---

- The 2<sup>nd</sup> model presents more accurate diagrams thanks to the use of the resistances.
- The simulation parameters were the same for the PD models; same applied voltages, same void geometries and same insulation materials. This was selected so that the results could be compared. The above results apply to all simulations of each model used in the present work.
- The results presented are a small sample of all the simulations made.

# Discussion (2/2)

---

- The results show that PD activity increases when the applied voltage and the volume of the void increases.
- The number of PDs in ER's and mica's simulations increase more when the radius becomes bigger rather than when the height increases.
- The insulation material that seems to have better behavior is the combination ER-Mica, since it presents a reduction of the number of PDs in most of the simulations.

# Conclusions

---

- Different geometries of a cylindrical void and different applied voltages were used in order to investigate how ER, mica and the combination of these two materials were affected through two different PD models.
- As for future work, simulations with different PD models, applied voltages and void geometries would be useful. These simulations can be combined with experiments or real PD measurements to adjust or improve the model and determine in a better way the condition of the insulation system.

# Questions

---

For questions, please contact [dvergina@ee.duth.gr](mailto:dvergina@ee.duth.gr) and we will answer your questions as soon as possible.



---

*Thank you very much for your time and  
your attention!*