

# Preserving The Great Mosque of Cordoba (Spain): A Preliminary Mechanical Characterization of its original Natural Stone <sup>†</sup>

Beatriz Zapico Blanco <sup>1,\*</sup>, José Daniel Rodríguez Mariscal <sup>2</sup>, Elena Zapata Rodríguez <sup>2</sup>, José Antonio Romero Arroyo <sup>2</sup>, Fernando Fernandez Ancio <sup>2</sup> and Mario Solís Muñiz <sup>2</sup>

<sup>1</sup> Department of Building Structures and Geotechnical Engineering, University of Seville, 41004 Sevilla, Spain

<sup>2</sup> Department of Continuum Mechanics and Structural Theory, University of Seville, 41004 Sevilla, Spain; email1@email.com (J.D.R.M.); email2@email.com (E.Z.R.); email3@email.com (J.A.R.A.); email4@email.com (F.F.A.); email5@email.com (M.S.M.)

\* Correspondence: bzapico@us.es

<sup>†</sup> Presented at the 1st International Online Conference on Buildings, 24–26 October 2023; Available online: <https://iocbd2023.sciforum.net/>.

**Abstract:** The Mosque of Cordoba (Spain) is an emblem of the rich cultural heritage of Western Andalusia. This research focuses on the mechanical characterization of the natural stone used in the building. Determining its properties is crucial to understanding the structural behaviour of the entire building. An experimental campaign with various mechanical tests, such as density, compression, indirect tensile, and bending tests, was conducted on more than 100 cubic and prismatic specimens obtained from the main quarry that supplies material for the mosque's restoration. The results indicate the stone's isotropic behaviour for the properties studied. Further analysis established correlations between compressive strength (averaging 6 MPa) and other mechanical properties. This preliminary characterization provides valuable information for future in-situ testing and more sophisticated lab techniques.

**Keywords:** Mosque of Cordoba; natural stone; compressive strength; tensile strength; anisotropy

**Citation:** Zapico Blanco, B.; Rodríguez Mariscal, J.; Zapata Rodríguez, E.; Romero Arroyo, J.; Fernandez Ancio, F.; Solís Muñiz, M. Preserving The Great Mosque of Cordoba (Spain): A Preliminary Mechanical Characterization of its original Natural Stone. *Eng. Proc.* **2023**, *53*, x. <https://doi.org/10.3390/xxxxx>

Academic Editor(s): Name

Published: 24 October 2023



**Copyright:** © 2023 by the authors. Submitted for possible open access publication under the terms and conditions of the Creative Commons Attribution (CC BY) license (<https://creativecommons.org/licenses/by/4.0/>).

## 1. Introduction

The Great Mosque of Córdoba is the most relevant monument in the entire Islamic West and one of the most remarkable worldwide. Its style is an impressive example of the unique Hispano-Muslim style during its peak. The mosque was built during the years 780 to 990, and completed with a Christian cathedral in the XII century, becoming the only temple in the world in which a mosque and a cathedral coexist. It was declared World Heritage Site by UNESCO in 1984 [1]. With over one million annual visitors, it is one of the region's major tourist assets. Its conservation is of utmost importance, and the knowledge of the monument's mechanical behaviour to ensure its structural stability over the years is key to that task. Central to this endeavour is the knowledge of the mechanical properties of its materials, and the possibility of acquiring that knowledge without creating any damage to the actual building is a challenge.

The non-destructive testing techniques that are mostly used for the characterization of materials in heritage buildings, such as the sclerometer or the ultrasounds test, provide results which are usually correlated with the compressive behaviour of the stone, i.e., its compressive strength. Thus, in this study, the natural stone present in the monument is characterized and correlations between the compressive strength and the tensile and bending strength were established.

## 2. Materials and Methods

The Mosque was built based on the *spolia* of other prominent buildings, comprising elements like roman marble columns or byzantine capitals. However, the largest part of the structure is constructed using Córdoba’s freestone, gathered in quarries from the nearby area. This stone, which is a bio-calcarenite, has been one of the most widely utilized lithic materials in the Córdoba region throughout history. In a significant number of Cordobese monuments, several types of biocalcarenites can be identified: biomicrite, biosparite, and biorudite [2]. They originate from the Tortonian marine marginal facies within the Guadalquivir Depression, comprising amalgamated carbonate deposits with a sandy matrix, notably enriched in fossils and sedimentary microfauna.

Given the impossibility of removing samples from the Córdoba’s Mosque itself, several ashlar of 40 × 30 × 10 cm were obtained from one of the region’s quarries, *Mármoles y Piedra Gutiérrez* [3], which is one of the main providers of natural stone for the restoration works in the Mosque. The ashlar were cut with the grain in the quarry. Based on this, the hypothesis was formulated that the stone could exhibit anisotropy in its mechanical properties with respect to the direction of natural compression, normal to the plane A in Figure 1. For the sake of simplification, it will be called direction A from now on.

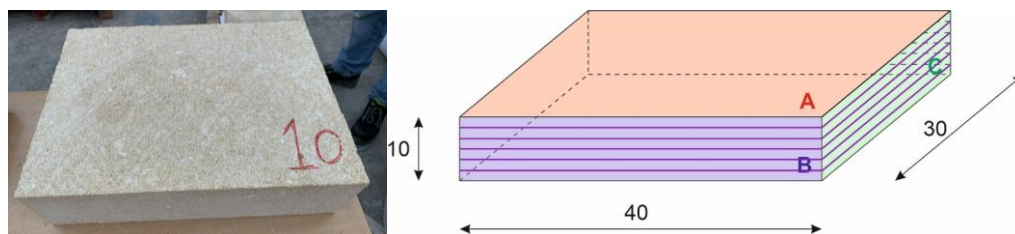

**Figure 1.** Ashlars provided by the quarry and assumed compression layers. Lengths in cm.

Three of the ashlars were cut in samples that would be used for the realization of three different destructive tests: uniaxial compression, three points bending and split or indirect tensile test. The design of the cutting scheme adhered the following criteria:

- The number and dimensions of the samples comply with the appropriate NEN code in each case [4–6]. In the case of the split test, where no code is available, the code for concrete was used for reference [7].
- To test the variability of the results between ashlars, samples for each of the three tests were extracted for each of the stone units.
- In order to run a sensitivity analysis on the loading direction [8], the number of samples were doubled, and the tests were performed once with the loading direction parallel to the assumed main direction (A) and then repeated with the loading direction perpendicular to it.
- With the goal of testing the influence of the sample dimensions [9,10] on the results, smaller (50 mm side) and larger (70 mm side) cubes were cut for the compression test, doubling again the number of samples.

As a result, a total of 100 samples were cut and then tested, with the following loading direction and dimensions:

**Table 1.** Codes, dimensions and number of samples to be tested for each test type.

Test	Uniaxial Compression		Three Points Bending		Split Test	
Code	UNE-EN 1926/2007		UNE-EN 12372/2007		UNE-EN 12390-1/2022	
Dimensions [mm]	50 × 50 × 50	70 × 70 × 70	50 × 50 × 300		50 × 50 × 100	
Direction	A	⊥ to A	A	⊥ to A	A	⊥ to A
Number	10	10	10	10	20	20

The tests were performed using a universal servo-hydraulic testing machine (200 kN capacity and 200 mm displacement stroke). The compression tests and the three-point bending test were executed under displacement control, whereas the split test was conducted using force control (loading speed of 125 N/s), due to the elevated fragility of the specimens. During the tests, the load in the piston and its displacement are recorded at every step. The tests set up can be seen in Figure 2:

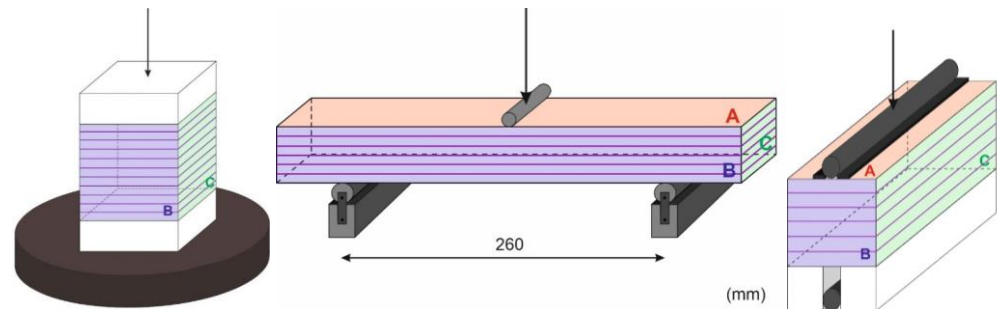

**Figure 2.** Tests set up for the uniaxial compression test (**left**), the three-point bending test (**middle**) and split test (**right**). The arrow shows the loading direction.

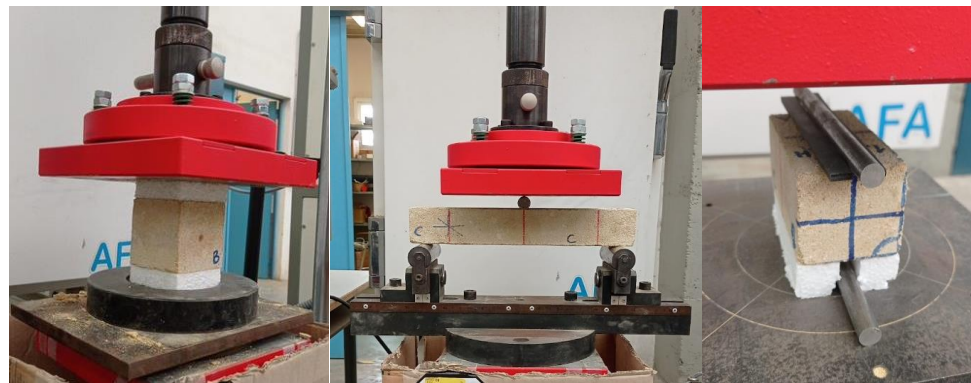

**Figure 3.** Images of the test set up for the uniaxial compression test (**left**), the three-point bending test (**middle**) and split test (**right**).

During the uniaxial compressive strength testing setup, it was decided to employ expanded polystyrene sheets to minimise the lack of parallelism of the faces effect, and to ensure a proper distribution of the load among the surfaces. The same material was used in the split test, in order to hold in place the rod under the specimen. The rod on top of the specimen was secured in position using neoprene strings.

The measures taken during the tests are processed to obtain the desired properties values as follows.

Uniaxial compression test:

$$f_c = \frac{F}{A} \tag{1}$$

Three-point bending test:

$$f_b = \frac{3 \cdot F \cdot l}{2 \cdot b \cdot h^2} \tag{2}$$

Split tests:

$$f_t = \frac{2 \cdot F}{\pi \cdot L \cdot b} \tag{3}$$

Where:

- F is the peak load
- A is the transversal section area of the sample

- $l$  is the length among loading points
- $L$  is the length of the contact line
- $b$  is the sample width
- $h$  is the sample thickness

The results of the different tests were compared with each other in order to obtain a correlation [11,12], which was assumed to be linear and proportional, following the equations:

$$f_b = \alpha f_c \text{ and} \quad (4)$$

$$f_t = \beta f_c$$

where  $f_c$ ,  $f_b$  and  $f_t$  are the stone compressive, bending and tensile strengths respectively. The comparison was made first per ashlar and then globally.

In addition to this, the density of the stone was investigated through three different methods:

- Nominal method: the density is calculated based on the nominal dimensions of the ashlars and samples and their measured weight.
- Measured volume method: a more accurate calculation of the volume was made by measuring the edges of the ashlars and samples and, from them, an average of the dimension in each direction is obtained, the product of which would be the measured volume. The density is then calculated dividing the mass of the sample between this value.
- Immersion method [13]: The samples were first put in a vacuum machine, where demineralised water is then introduced, and the samples remain submerged for at least 15 min. Once the samples are submerged, the pressure is set back to atmospheric levels, and the submersion continues for another 24 h. In this specific study, it was decided to leave the samples immersed until complete saturation. Measures were taken after 24 h and after 168 h. Given its consuming nature, this study was performed on six of the 5 cm side cubic samples, each two of them originating from one of the studied ashlars.

The three methods results were compared against each other, in order to select the optimal one. Consequently, the density results were compared with the compressive strength values, with the aim of obtaining a correlation. In this case, because both values were available for each of the samples, a linear regression was used for the task.

### 3. Results

The results of the destructive tests performed can be seen in Table 2, both in mean value and standard deviation. The results are shown first per individual ashlar and then globally, and separated based on the specimen dimensions and on the loading direction.

**Table 2.** Summary of the results.

Property	Dimensions [mm]	Ashlar	Direction	Mean [MPa]	STD [MPa]
Compressive Strength	50 × 50 × 50	1	A	5.78	0.44
			⊥ to A	5.95	1.47
		2	A	5.79	0.64
			⊥ to A	5.09	0.79
		3	A	6.69	0.51
			⊥ to A	6.82	0.80
		All	A	6.06	0.66
			⊥ to A	5.61	1.09
	70 × 70 × 70	1	A	7.05	0.47

			⊥ to A	6.34	1.54
		2	A	6.24	1.02
			⊥ to A	6.26	0.31
		3	A	5.66	0.53
			⊥ to A	5.54	1.93
		All	A	6.33	0.85
			⊥ to A	6.00	1.48
Bending Strength	50 × 50 × 300	1	A	1.93	0.35
			⊥ to A	2.11	0.07
		2	A	1.94	0.04
			⊥ to A	1.93	0.12
		3	A	1.78	0.52
			⊥ to A	1.91	0.27
		All	A	1.9	0.30
			⊥ to A	2.0	0.20
Tensile Strength	50 × 50 × 100	1	A	0.70	0.06
			⊥ to A	0.69	0.10
		2	A	0.72	0.10
			⊥ to A	0.67	0.07
		3	A	0.68	0.09
			⊥ to A	0.73	0.09
		All	A	0.70	0.08
			⊥ to A	0.70	0.08

The results of the correlation coefficients are shown in the following table:

**Table 3.** Correlation coefficients.

Ashlar	Compressive vs. Bending Strength Coefficient ( $\alpha$ )	Compressive vs. Tensile Strength Coefficient ( $\beta$ )
1	0.32	0.11
2	0.33	0.12
3	0.30	0.11
All	0.32	0.11

Regarding the density, the results of the three methods can be seen in Table 4 for the six selected samples and their original ashlar, for the sake of clarity:

**Table 4.** Densities.

Ashlar/Sample	Nominal	Measured Volume	Immersion (24 h)
Ashlar 1	1742	1814	-
Ashlar 2	1833	1833	-
Ashlar 3	1858	1858	-
Sample 1.1	1665	1798	1822
Sample 1.2	1686	1776	1808
Sample 2.1	1766	1789	1815
Sample 2.2	1717	1783	1808
Sample 3.1	1780	1809	1841
Sample 3.2	1793	1793	1829

Figure 4 shows the density vs. the compressive strength of the material, and the mathematical expression of the founded correlation can be seen in Equation (5).

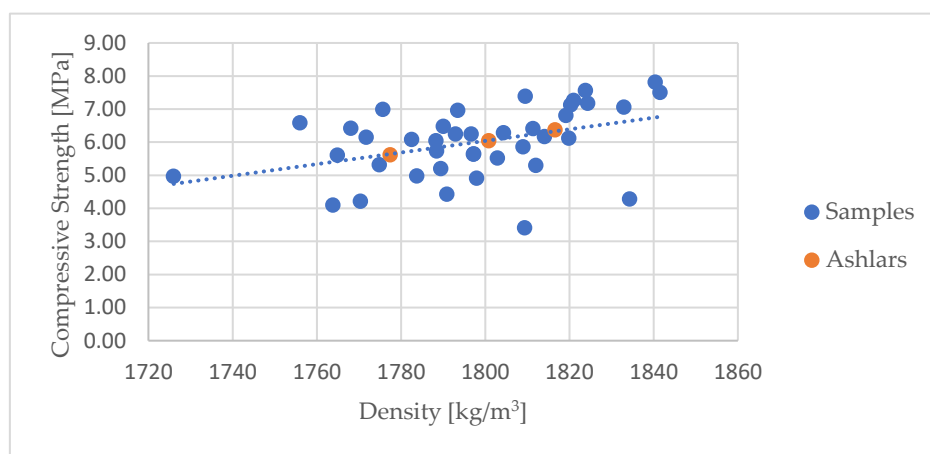

**Figure 4.** Correlation between density and compressive strength for the individual samples (blue dots) and each of the ashlar (orange dots). The linear regression is shown in a dotted blue line.

$$D = 56.8 \cdot f_c + 1452.8 \tag{5}$$

#### 4. Discussion

The average value of the compressive strength of the stone, as can be seen in Table 2, is of almost 6 MPa, with a standard deviation of around 1.5 MPa. The first study performed on the compressive strength results was the comparison between the performance of smaller and larger samples. Although the smaller samples (50 mm side) showed a smaller average compared with the larger ones (70 mm side), this difference of 0.4 MPa is negligible, given that it falls within the boundaries of the property variability. These figures indicate the lack of dependence of the results with the sample dimension.

The second study aims to corroborate or refute the hypothesis of the existence of a stronger direction, coinciding with the natural compression direction of the stone. This would result in a transverse anisotropy of the material. When the results obtained for each of the two loading directions are compared, the material strength could seem slightly higher in the main direction, by 0.4 MPa in the smaller cubes and 0.3 MPa in the larger ones in the case of the compressive strength. However, this difference is insignificant when the dispersion is taken into account. This is even more clear in the results of the bending and tensile tests, when the difference per loading direction is virtually zero.

After comparing the results of the destructive tests with the reviewed literature, it is observed that the stone from Santa María de Cuenca [14] is similar in terms of compressive strength. Additionally, after studying the effect of the testing direction, it proves to be isotropic, like the biocalcarenite studied.

The average value of the bending strength was found to be  $2.0 \pm 0.2$  MPa, while the tensile strength was  $0.7 \pm 0.1$  MPa. These values were compared with the compressive strength of the stone, in order to obtain a correlation. The results were not comparable at sample level, given that samples that were tested in compression were not tested for bending or tension. Consequently, a regression analysis was not possible, and a simple proportional correlation was supposed. The correlation coefficient was obtained comparing average ashlar values of each of the properties, with results that can be seen in Table 3 and in Equation (6)

$$\begin{aligned} f_b &= \alpha \cdot f_c \rightarrow f_b = 0.32 \cdot f_c \\ f_t &= \beta \cdot f_c \rightarrow f_t = 0.11 \cdot f_c \end{aligned} \tag{6}$$

The values of the density obtained using different methods, ranging roughly from 1700 to 1800 kg/m<sup>3</sup>, were compared. These values are in line with the ones found in literature for San Cristobal's stone [15]. The nominal method, which is the faster and the less accurate, does not take into account deviations of the cube's dimensions from the nominal ones (5 × 5 × 5 cm). Given the natural inaccuracy of stone cutting, using the nominal method implies an error that could be as high as 7.4% for the studied samples, when compared with the measured volume one, making the fastest method unacceptable.

Regarding the immersion method, the longer the samples stay under water, the more accurate the measurement would be. However, when the results of the method employing 168 h vs. 24 h are compared, it can be observed that the error committed with shorter times is of less than 0.7% in any case, which suggest that the measurement could be carried out after only 24 h immersion time without significant loss of accuracy.

Finally, when the immersive method (24 h) is compared with the measured volume one, the resulting values are quite similar, with an average error of 1.6%, taking the immersive results as a reference.

Observing the values in Table 4, the ashlars seem to be denser than their individual samples. This could be attributed to the unintentional drying of the stone that occurs while cutting the test samples, added to the fact that stones with higher moisture content have greater mass and therefore higher density.

The material density seems to be linked to its compressive strength, at least for the studied range of values. In this case, the comparison between the two properties could be done sample by sample, using the measured volume density. Consequently, a regression analysis was possible. A linear regression was selected, given the short range of the result values obtained. When the values of the ashlar properties are compared with the obtained correlation line (see Figure 4), it can be seen that the match is quite good.

## 5. Conclusions

A mechanical characterization of the natural stone used for the construction of the Córdoba's Mosque (biocalcarenite) has been performed, including density and compression, bending and tensile strength. The campaign was designed in order to determine whether the stone behaves in a transverse anisotropic way, with the hypothesis of its natural compression direction being a stronger one. In addition to this, a sensitivity analysis of the results regarding the sample dimensions was performed. In order to link the results with possible in-situ testing, which usually provide information regarding the compressive behaviour of the material, correlations were determined between the compressive strength and both the tensile and bending strengths of the stone. Similarly, the compressive strength of the material was correlated with its density. The following conclusions can be drawn.

1. The proposed campaign proved to be successful for the consecution of the established goals. The resulting mechanical properties values, which can be found in Table 5, are in line with results from studies found in the reviewed literature for similar stones.

**Table 5.** Mechanical properties values.

Ashlar	Compressive Strength [MPa]		Bending Strength [MPa]		Tensile Strength [MPa]		Density [kg/m <sup>3</sup> ]	
	Mean	STD	Mean	STD	Mean	STD	Mean	STD
1	6.27	1.06	2.02	0.25	0.70	0.07	1815.08	9.76
2	5.81	0.83	1.94	0.09	0.69	0.09	1811.26	4.81
3	6.17	1.20	1.83	0.40	0.70	0.09	1834.92	8.97
<b>All</b>	<b>6.08</b>	<b>1.06</b>	<b>1.93</b>	<b>0.27</b>	<b>0.70</b>	<b>0.08</b>	<b>1820.00</b>	<b>13.00</b>

2. The variation inter- and extra-ashlar were similar, indicating the homogeneity of the material.
3. Based on the obtained results, it can be stated that there is no anisotropy in the stone for the studied properties.
4. It can be concluded that the influence of the sample dimensions on the results of the compressive strength test are negligible, at least within the range of sizes studied.
5. The optimal method for the determination of the stone density is found to be the measured volume method. The nominal method, although quick, could lead to errors of up to 7% in the sample volume. The immersive method is more accurate, but only by less than 2%, which does not justify its cost terms of time. When employed, an immersion time of 24 h produces enough accuracy. Allowing the samples to saturate for a longer time leads to more accurate results, but only by a marginal percentage (<0.6%). Based on this, the determined stone average density is 1820 +/- 10 kg/m<sup>3</sup>.
6. The bending strength of the material can be approximated by one third of its compressive resistance, while the tensile strength is around one 10% of it. The density of the stone can be derived from its compressive strength by means of a linear relation with slope 56.8 and y intercept 1452.8, when the strength is expressed in MPa and the density in kg/m<sup>3</sup>.

**Author Contributions:** All authors contributed equally to this work. All authors have read and agreed to the published version of the manuscript.

**Funding:** This research received no external funding.

**Acknowledgments:** The authors express their appreciation to *The Córdoba Cathedral Chapter of Canons* for their availability and excellent cooperation in facilitating this study, as well as to the conservation architect Professor Gabriel Rebollo for his exceptional generosity in sharing his time and knowledge. Sincere gratitude is extended to the quarry *Mármoles y Piedras Gutierrez* (<http://www.mypg.es>) for their generous contribution of the natural stone units used in this research study. This study would not have been possible without the invaluable help of Miguel Carrión Colchero and Lidia Molina Sanz, head of the structures and soil labs, respectively.

**Conflicts of Interest:** The authors declare no conflict of interest.

## References

1. National Geographic. *La Mezquita de Córdoba, el esplendor de Al-Andalus*. [https://historia.nationalgeographic.com.es/a/mezquita-cordoba-esplendor-al-andalus\\_16265](https://historia.nationalgeographic.com.es/a/mezquita-cordoba-esplendor-al-andalus_16265) (accessed on).
2. Barrios Neira, J; Montealegre, L. *Contribución al estudio litológico de los materiales empleados en monumentos de Córdoba de distintas épocas*; CSIC: Madrid, Spain, 2003; pp. 1–7.
3. Mármoles y Piedras Gutierrez. Available online: <http://mypg.es/index2.html> (accessed on).
4. *UNE-EN 1926-2007*; Métodos de ensayo para la piedra natural. Determinación de la Resistencia a la compression uniaxial. AENOR: Madrid, Spain, 2007.
5. *UNE-EN 12372-2022*; Métodos de ensayo para Piedra natural. Determinación de la Resistencia a la flexion bajo carga concentrada. AENOR: Madrid, Spain, 2022.
6. *UNE-EN 1936-2007*; Métodos de ensayo para Piedra natural. Determinación de la densidad real y aparente y de la porosidad abierta y total. AENOR: Madrid, Spain, 2007.
7. *UNE-EN 12390-1-2022*; Ensayos de hormigón endurecido. Resistencia a tracción indirecta de probetas; AENOR: Madrid, Spain, 2022.
8. Oliveira, D; Lourenço, P. Cyclic Behaviour of Stone and Brick Masonry under Uniaxial Compressive Loading. *Mater. Struct.* **2006**, *39*, 247–257.
9. Kaklis, K; Mavrigiannakis, S. Experimental Investigation of the Size Effect on the Mechanical Properties on two Natural Building Stones. In *Proceedings of the 8th GRACM International Congress on Computational Mechanics*, Volos, Greece, 12–15 July 2015; pp. 1–11.
10. Kourkoulis, S; Papageorgiou, E. Experimental study of the size- and shape-effects of natural building stones. *Constr. Build. Mater.* **2010**, *24*, 803–810.
11. Aliabdo, A; Elmoaty, A. Reliability of using nondestructive tests to estimate compressive strength of building stones and bricks. *Alex. Eng. J.* **2012**, *51*, 193–203.



12. Aguilar; L.A. Correlaciones entre Resistencia a la compression, flexion y tracción por compression diametral de hormigones para pavimento con agragado calcareo de tamaño 19 mm. Bachelor's Thesis, European School of Political and Social Sciences: Lille, France, 2001.
13. UNE.EN 103302-1994; Determinación de la densidad relativa de las partículas de un suelo; AENOR: Madrid, Spain, 1994.
14. Torrero Fuentes. Caracterización, degradación y conservación de pétreos naturales en la catedral de Santa María de Cuenca. Ph.D. Thesis, Universidad de Castilla-La Mancha: Ciudad Real, Spain, 2015.
15. Baeza, J; Compán, V. Determining static elastic modulus of weak sandstone in Andalusian historical constructions from non-destructive tests: San Cristobal's stone. *J. Build. Eng.* **2022**, *57*, 104864.

**Disclaimer/Publisher's Note:** The statements, opinions and data contained in all publications are solely those of the individual author(s) and contributor(s) and not of MDPI and/or the editor(s). MDPI and/or the editor(s) disclaim responsibility for any injury to people or property resulting from any ideas, methods, instructions or products referred to in the content.