

Experimental Study of Temperature Effects on the Dynamic Response of Medium and Low Speed Maglev Trains [†]

Guofeng Zeng ¹, Andong Zheng ^{2,*}, Stefano Mariani ² and Ziping Han ¹

¹ Maglev Transportation Engineering R&D Center, Tongji University, Shanghai 201804, China; email1@email.com (G.Z.); email2@email.com (Z.H.)

² Department of Civil and Environmental Engineering, Politecnico di Milano, Milan, Italy; email3@email.com

* Correspondence: email4@email.com

[†] Presented at The 11th International Electronic Conference on Sensors and Applications (ECSA-11), 26–28 November 2024; Available online: <https://sciforum.net/event/ecsa-11>.

Abstract: To ensure safety and passenger comfort, for the medium and low speed Maglev transportation system very strict control standards were developed and set into action. The relevant high costs are therefore not conducive to the promotion of this advanced mode of transportation. Moving from the above described situation, field tests were carried out at the Maglev test line located in Shanghai Lin'gang. The dynamic response of Maglev system was studied under the influence of beams of the supporting frame with a varying stiffness, and under different environmental (in terms of temperature) effects. The collected data showed that the system can guarantee a good stability under relatively unfavorable ambient conditions, so that the effect of temperature on the dynamic response of the system lies within an acceptable range.

Keywords: temperature effect; dynamic response; field test; steel beam; medium and low speed maglev system

1. Introduction

As a transportation means characterized by low noise, flexible route selection, comfortable ride, and green economy-like properties, the medium and low speed Maglev transportation proves suitable for the current needs of densely urbanized areas. It therefore features broad development prospects. At present, Germany, China and Japan have developed a relatively mature research for the adoption of Maglev as a transportation system. China high-speed Maglev lines in Shanghai have been in safe operation for over 20 years, and the medium-speed Maglev lines in Beijing and Changsha have already been put into commercial use. Germany and Japan have a long-term technical analysis of high- and medium-low speed Maglev trains, respectively. In addition, the Netherlands also actively conducted a “hyperloop” test in 2024, which is indeed a vacuum tube Maglev system. At present, there is not a huge number of medium-low speed Maglev lines built and put into use in the world, hence relatively few tests under complex working conditions were obtained. Due to the above reasons, the current operations of the medium and low speed Maglev lines all over the world usually adopt strict control standards. Taking China as an example, according to the “medium and low speed Maglev traffic design Code” CJJ/T 262-2017 [1], only the deformation control of concrete beams is mentioned while nothing is prescribed in relation to the control of steel beams.

Some research activities have then carried out a related work. The temperature of the medium and low speed Maglev operating line in Changsha was monitored by Dai [2] for one and a half years. Then the temperature time history of the measuring point is analyzed, and the track temperature time history curve is derived by fitting. A finite element model of steel box beam was established by Li [3] and combined with field measurements,

Citation: Zeng, G.; Zheng, A.; Mariani, S.; Han, Z. Experimental Study of Temperature Effects on the Dynamic Response of Medium and Low Speed Maglev Trains. *Eng. Proc.* **2024**, *5*, x. <https://doi.org/10.3390/xxxxx>

Academic Editor(s):

Published: 26 November 2024



Copyright: © 2024 by the authors. Submitted for possible open access publication under the terms and conditions of the Creative Commons Attribution (CC BY) license (<https://creativecommons.org/licenses/by/4.0/>).

to fit the horizontal and vertical temperature gradient curves of the Maglev steel box girder under the action of sunshine. Another finite element model was established by Huang [4] by combining the meteorological data of Shanghai and Qingdao and the data of the existing literature, to study and compare the temperature gradient fitting formulas for the high-speed Maglev concrete box beams under the changing environmental effects induced by the sunshine and wind. The temperature field distribution of double-compartment box girder was analyzed by Zou [5] under solar irradiation, and the corresponding temperature distribution law was obtained. Arkadiusz Kampczyk [6] has proposed an innovative solution for monitoring the state of temperature and other atmospheric conditions, using wireless temperature loggers to take measurements at the same measuring point on the railway at a fixed time interval between January and May (winter/spring), indicating a new scheme for obtaining railway temperature data.

By the analysis of the above reported current research status, there seems to be no experimental activities related to the influence of temperature on the dynamic response of the medium and low speed Maglev steel beams, neither as specified in the existing design specifications nor as scholars research. In the activity here reported, the Maglev test line in Shanghai harbor was selected for field test research, and data were collected under varying environmental conditions. In the remainder of the paper, the field tests and the adopted test equipment are described in Section 2, while the collected measurements are reported in Section 3. Some concluding remarks on the experimental work are finally summarized in Section 4, along with suggestions to further add information on the collected data and extend the range of application of the inferred results linked to the response of the structural system.

2. Field Tests

Field test were carried out at the medium-low speed Maglev test line located in Shanghai Lin'gang. In the following, details regarding the specific conditions during the tests are detailed.

2.1. Test Equipment

Since the purpose of the present field tests was to assess the influence of low-stiffness steel beam and environmental effects (primarily in terms of temperature) on the dynamic response of tested Maglev system, displacement and acceleration sensors were arranged in a network and mounted on the rail and beam of the tested section. Additionally, to sense the onboard comfort also acceleration sensors were deployed on the test vehicle.

The acceleration measurements were collected on the floor of the coach, on the vehicle suspension frame, and on the F-type rail and track beam made of steel. Hence, the INV9828 ICP piezoelectric accelerometer (Figure 1) was used, which is directly adsorbed to the test object by a neodymium magnet. Its features are as follows: sampling frequency 0.5~1 kHz; resolution 0.0004 m/s²; transverse ratio less than 5%; operating temperature in the range between -20 and 120 °C; resonance frequency 8 kHz, to meet the test range and accuracy requirements for the tests.



Figure 1. Adopted INV9828 ICP piezoelectric accelerometer.

The displacement sensors used in the tests was manly meant to monitor the deformation of the track beam and the F-type rail. In order to adapt to the test conditions at different positions, contact and laser displacement sensors were therefore used, respectively. Figure 2a shows a Keyu LVDT-WYDC contact-type displacement sensor with a measuring range of ± 25 mm, a dynamic response frequency of up to 200 Hz, and accuracy of 0.05%; Figure 2b shows instead a Panasonic HG-C1030 laser displacement sensor with a measuring range of ± 35 mm and a repetition accuracy of 70 μm .

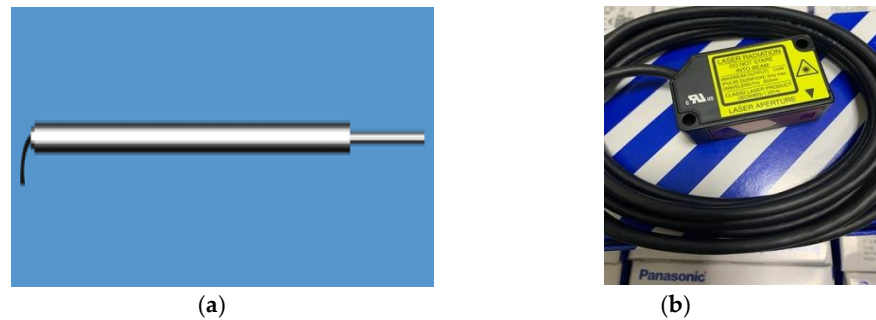

Figure 2. Adopted displacement sensors: (a) Keyu LVDT-WYDC contact displacement sensor; (b) Panasonic HG-C1030 laser displacement sensor.

2.2. Test Set-Up

As already pointed out, the aim of this field test campaign was to assess the effects of the bridge features on the comfort (and safety) of medium and low speed Maglev vehicles. Accordingly, one span of concrete track beam and one span of steel track beam, both 25 m long, were tested in a simply supported configuration, see Figure 3.



Figure 3. Pictures taken on the test site: (a) exemplary concrete beam; (b) test vehicle passing by a simply supported steel beam.

The cross-sections of the concrete and steel beams considered in the tests are shown in Figure 4, and the relevant characteristics are collected in Table 1. The flexural stiffness of a steel beam amounts to 89% of that of a concrete beam while the weight of the steel beam being only 26.8% of the concrete beam one. The noteworthy feature to report is the small difference, amounting to around 3%, in the natural vibration frequencies of the two beams.

Table 1. Cross-section characteristics of the concrete and steel beams.

Material/ Girder Depth (m)	Mass (kg/m)	Flexural Stiffness (N m ²)	f_1 (Hz)
C60 concrete/1.7	3996	2.0254×10^{10}	7.45
Q235C steel/2.1	1071	1.8025×10^{10}	7.69

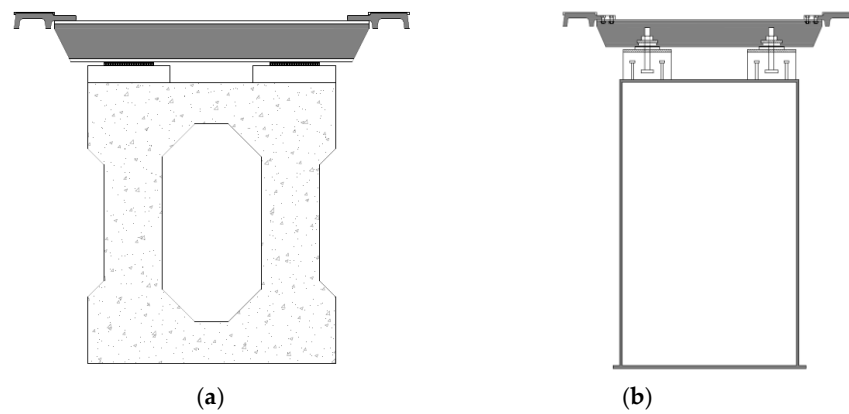

Figure 4. Cross-sections of the tested (a) concrete beam, and (b) steel beam.

The arrangement of measurement points selected during the experiments is shown in Figure 5. The Maglev vehicle passed by the concrete and steel beams successively, at a constant speed, and the displacement and acceleration sensors were used to record the dynamic response of the whole system. To maximize the sensitivity to the sought characteristics of the monitored structure, the sensors on rail and beam were all located in the middle of the span, while the sensor on the vehicle was located on the central floor of the coach. The dynamic response measuring points for the two span test beams and the test vehicle are also collected in Table 2. In addition to all the above mentioned measuring points, temperature measurements were collected at the top and bottom sides of the steel beam, at mid-span; the temperature was collected every 15 min, through a thermal conductive silica gel fixed at the test position.

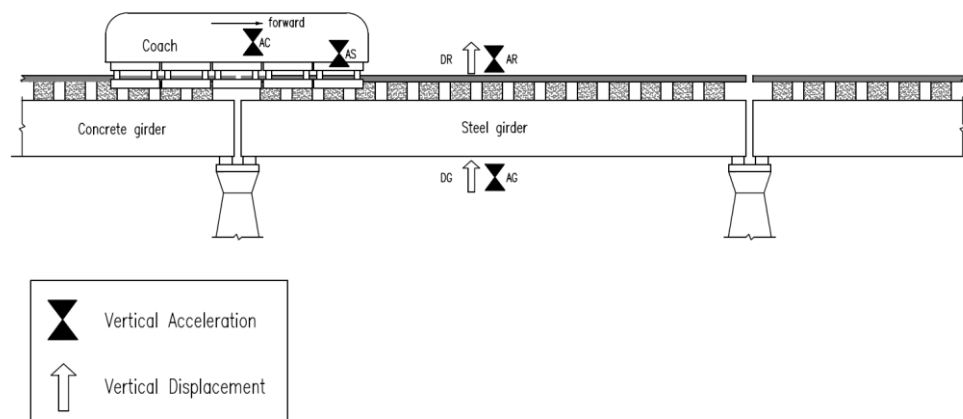

Figure 5. Test set-up and measurement points layout.

Table 2. Additional features of the measurement points arrangement.

No.	Location	ID/Type
1	Mid-coach	AC/Acceleration
2	Mid-1# suspension frame	AS/Acceleration
3	Mid-span F-type rail	AR/Acceleration
4	Mid-span steel girder	AG/Acceleration
5	Mid-span F-type rail	DR/Displacement
6	Mid-span steel girder	DG/Displacement

2.3. Test Conditions

The test vehicle was driven at a constant speed of 60 km/h, moving over the concrete track beam and the steel track beam in turn. In order to also study the effects of temperature on the test results, the tests were carried out in winter and also in summer. The temperature of the top and bottom sides of the steel beam and the relevant Mid-span displacement due to temperature on the test day are reported in Table 3.

Table 3. Temperature conditions and beam deformation on the test days.

Date	Mid-Span Displacement due to Temperature (mm)	Top Bottom Temperature Difference (°C)
27 January 2021 (Winter)	-0.14	1.7
6 August 2020 (Summer)	-2.99	14.2

3. Collected Measurements and Preliminary Signal Processing

The time histories collected during the experimental tests under different environmental conditions were next analyzed, to infer the dynamic response of the system. More specifically, the deformation of the beam (reported in terms of the collected deflections) and the acceleration are discussed in the following.

The results are reported in Figure 6 in terms of beam deformation measured along the girder and at the rail, and a comparison is shown between the data collected in Winter and Summer. In the two tests, the maximum deformation of the steel beam resulted to be 3.25 mm in Winter and 3.14 mm in Summer. When the steel beam had a large reverse arch caused by the thermal effect, its dynamic deformation became slightly smaller. As far as the deformation of F-rail is concerned, as the sensor was fixed to the top side of the steel beam, the relative deformation of the two structural parts was obtained and amounted to 0.34 mm in Winter and 0.36 mm in Summer. This value was therefore basically unaffected by the environment/temperature.

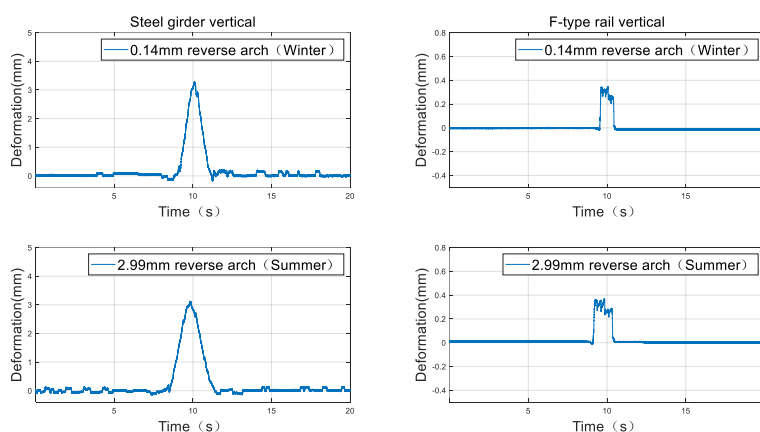

Figure 6. Deformation of steel girder and F-type rail: comparison between the data collected in Winter (top row) and Summer (bottom row).

Figures 7 and 8 next show the time histories of the vertical accelerations of the vehicle and of the track system, respectively. The maximum values of the different accelerations measured on the vehicle passing are also gathered in Table 4, and compared with the relevant deformation level obtained with the displacement sensors. Regarding the track system, it can be seen that the presence of reverse arch effect had slightly increased the amplitude of the accelerations of F-rail and steel track beam, by 7% and 5% respectively. Regarding instead the vehicle, due to the control feedback algorithm of the vehicle

suspension system and the filter effect of the air spring, the same reverse arch effect had no influence on the amplitude of the vibrations measured at the suspension frame and on the vehicle body.

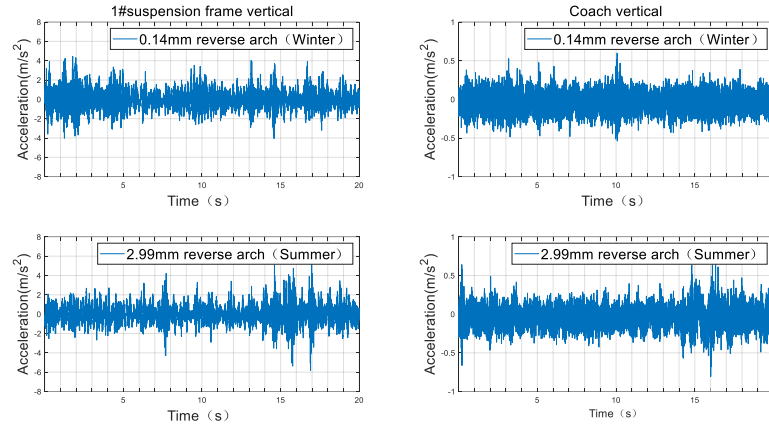

Figure 7. Vertical acceleration of the suspension frame and coach: comparison between the data collected in Winter (top row) and Summer (bottom row).

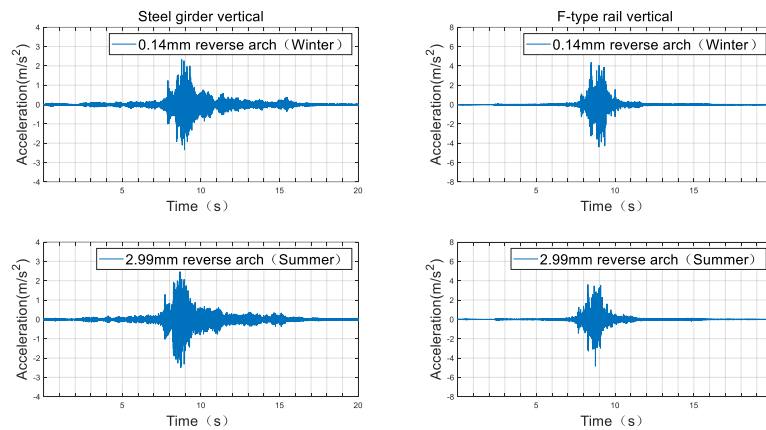

Figure 8. Vertical acceleration of steel girder and F-type rail: comparison between the data collected in Winter (top row) and Summer (bottom row).

Table 4. Values of the maximum acceleration measured during the tests, and relevant deformation level.

Deformation (mm)	Steel Girder (m/s ²)	F-Type Rail (m/s ²)	Coach (m/s ²)	Suspension Frame (m/s ²)
0.14	2.34	4.12	0.35	3.08
2.99	2.46	4.43	0.37	3.13

4. Conclusions and Outlook

In this paper, results have been reported as collected in an experimental campaign to study the dynamic response of medium and low speed Maglev vehicles to changing environmental conditions and stiffness of the structural system. A network of sensors was deployed to monitor the time evolution of displacements and accelerations, and the effect of the changing environment was accounted for in terms of the ambient temperature by running the tests in two different seasons.

The collected data showed the existence of a reverse arch effect, so that deformation of the steel beam induced by the dynamic load was slightly smaller in Summer than in

Winter. The other way around, the deformation of the F-rail relative to the steel beam was not affected by the environmental conditions. The vertical acceleration amplitude measured for the F-rail was larger than that of the steel beam; furthermore, in terms of maximum values, the vertical acceleration of the F-rail resulted to be slightly larger than that of the steel beam, again due to the reverse arch effect.

As the coach and suspension frame were connected by air spring, which provides a good vibration filtering effect, the acceleration amplitude at the car body was not affected by the reverse arch induced by the temperature effect. At the same time, the suspension control also had a strong robustness against this effect, and can be well adapted to the steel beam in the test.

The collected data are going to be further processed in the future, to assess the influence of the structural (bending) stiffness on the comfort and on the reliability of the entire system. Specifically, steel beams with lower stiffness will be studied to replace the current concrete ones, and dynamic tests are going to be carried out to look for the critical point between safety and economy. In addition to the vertical deformation, the influence on system dynamics of the lateral one caused by uneven temperature effects will be studied too.

Author Contributions: Investigation, resources and methodology, G.Z.; visualization, writing—original draft preparation, A.Z.; methodology, writing—review and editing, S.M. and G.Z.; project administration Z.H. All authors have read and agreed to the published version of the manuscript.

Funding: This research was funded by China scholarship council, grant number 202308620107.

Institutional Review Board Statement: Not applicable.

Informed Consent Statement: Not applicable.

Data Availability Statement:

Conflicts of Interest:

References

1. Ministry of Housing and Urban-Rural Development, People's Republic of China. Code for design of medium and low speed maglev transit: CJJ/T 262-2017[S], 2017.
2. Dai, G.; Yang, L. Time-history analysis of temperature field of medium-low maglev guideway girder. *J. Southwest Jiaotong Univ.* **2019**, *54*, 227–223.
3. Li, G.; Wang, C. Research on temperature and thermal deformation of steel box maglev guideway caused by solar radiation. *China Civ. Eng. J.* **2019**, *52*, 45–55.
4. Huang, Q.; Teng, N. Sunlight temperature effect analysis of large-scale box girder of high-speed maglev. *Railw. Stand. Des.* **2020**, *64*, 75–81.
5. Zou, B.; Teng, N. Temperature field analysis of concrete twin-celled single box maglev guideway caused by solar R adiation. *Railw. Stand. Des.* **2019**, *63*, 96–106.
6. Kampczyk, A.; Dybeł, K. The Fundamental Approach of the Digital Twin Application in Railway Turnouts with Innovative Monitoring of Weather Conditions. *Sensors* **2021**, *21*, 5757. <https://doi.org/10.3390/s21175757>.

Disclaimer/Publisher's Note: The statements, opinions and data contained in all publications are solely those of the individual author(s) and contributor(s) and not of MDPI and/or the editor(s). MDPI and/or the editor(s) disclaim responsibility for any injury to people or property resulting from any ideas, methods, instructions or products referred to in the content.