

# Comparison the performance of DC motor's and PMSM's control based on the SFS Algorithm

Naima Rahoua<sup>1</sup>, Nacira Tkouti<sup>1</sup>, Abir Betka<sup>2</sup>, Raihane Mechgoug<sup>1</sup>

<sup>1</sup> Department of Electrical Engineering, University of Biskra, Algeria

<sup>2</sup> Department of Electrical Engineering, University of El-Oued, Algeria

## Abstract

In modern electric drive systems, DC motors and PMSMs offer distinct advantages. DC motors excel in simplicity and precise speed control, while PMSMs provide higher efficiency and superior performance for demanding applications. This poster presents the application of the Stochastic Fractal Search (SFS) Algorithm to optimize PI controller parameters for speed control in both motors, comparing their performance. The SFS algorithm minimizes the Integral of Time-weighted Absolute Error (ITAE) to enhance control stability, overshoot, rise time, steady-state error, and settling time. Results show significant improvements, with the PMSM control system outperforming the DC motor, highlighting the effectiveness of the SFS algorithm for advanced PMSM applications.

## Stochastic fractal search(SFS)

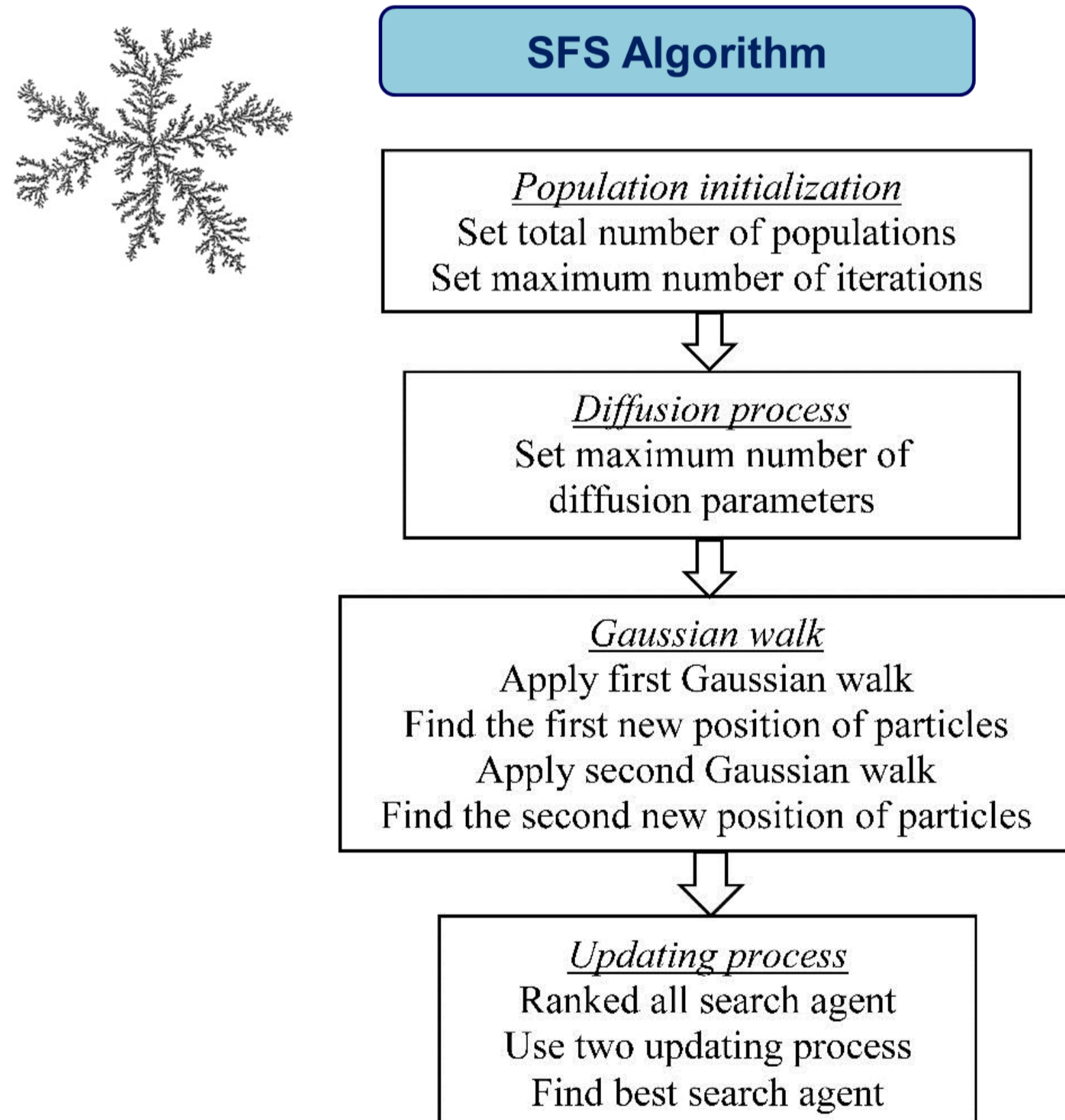

## Control of PMSM Motor with SFS Method

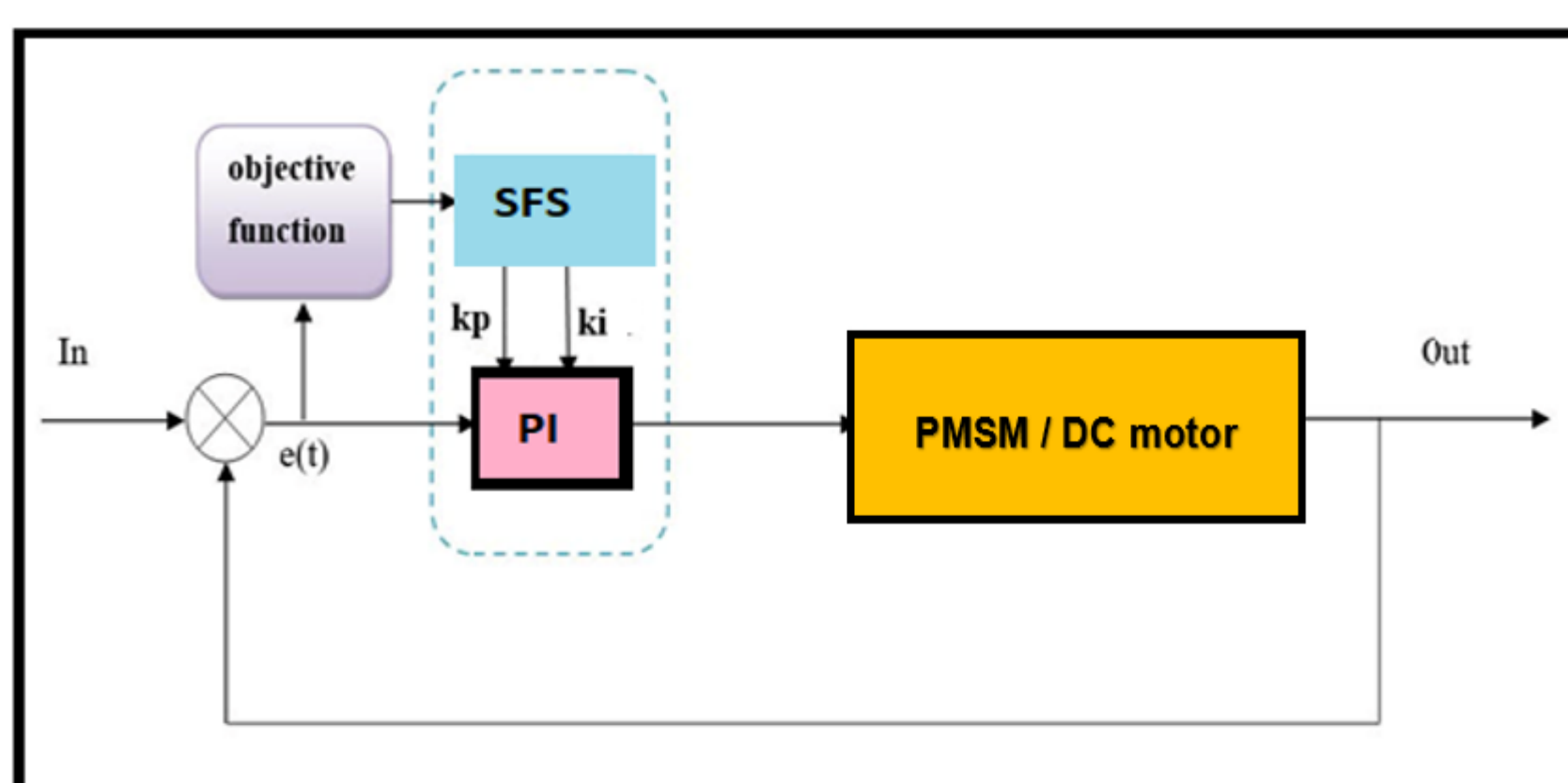

The objective function is:  $ITAE = \int_0^{\infty} t|e(t)|dt$

## Simulation results

Objective function

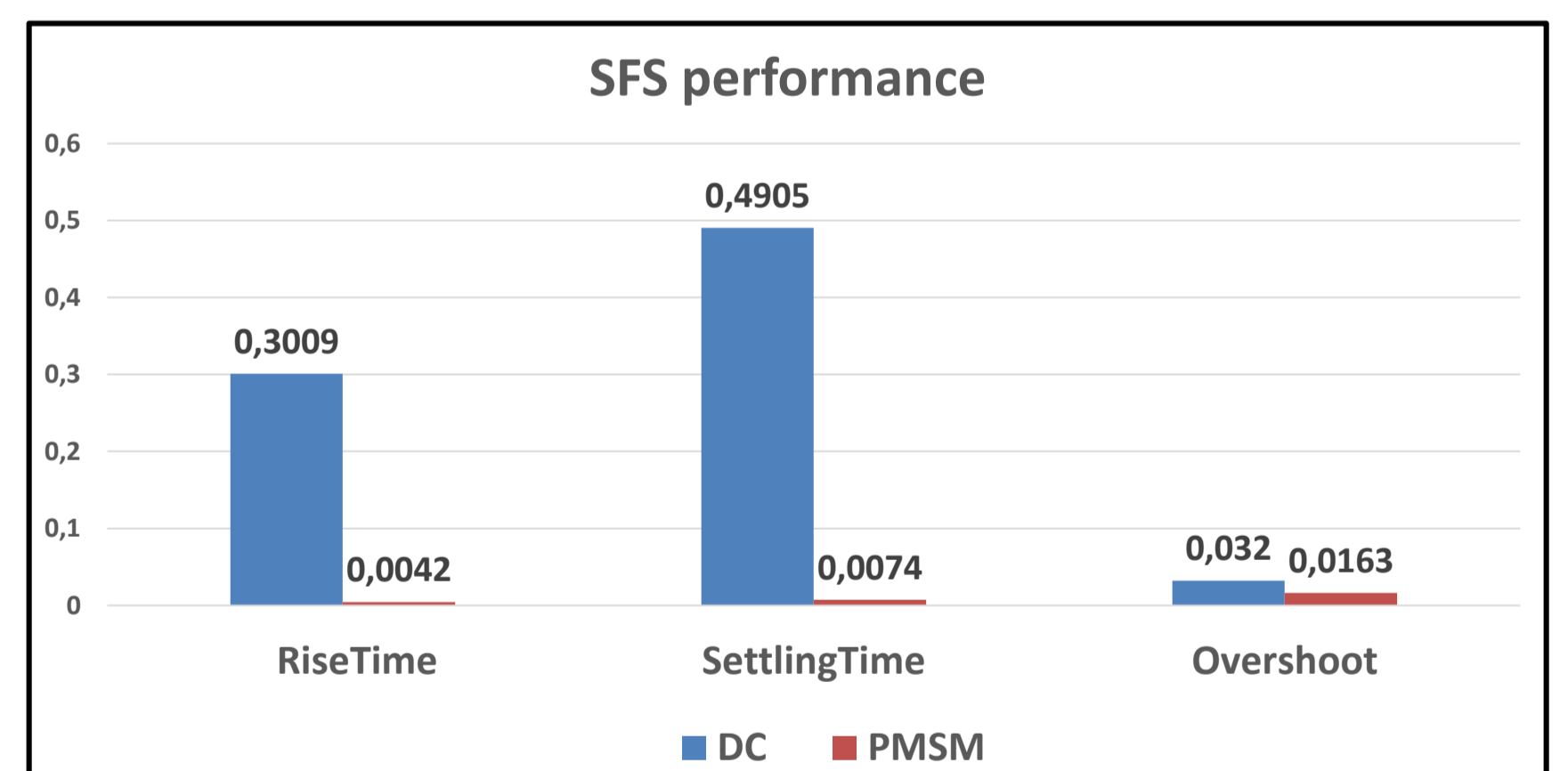
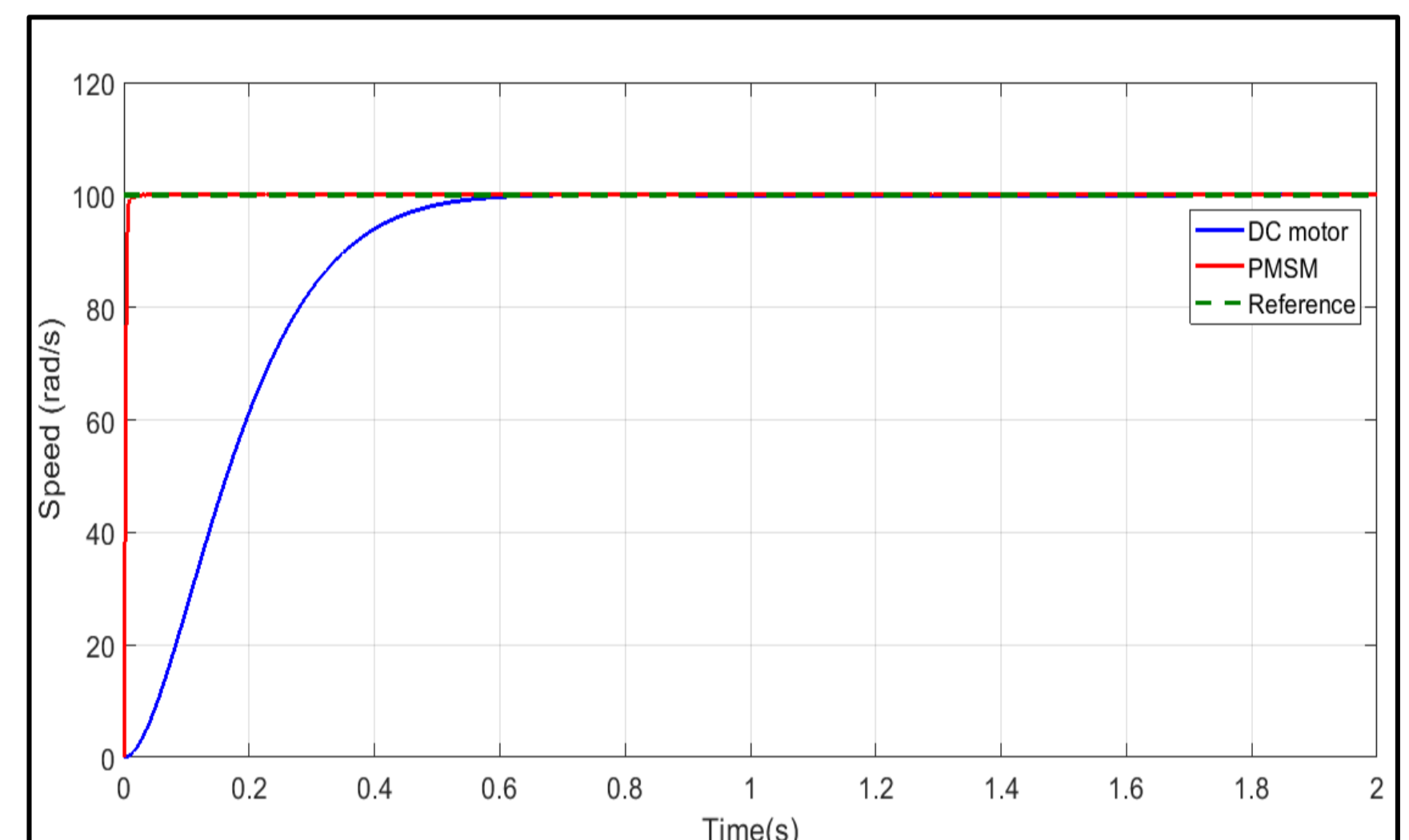
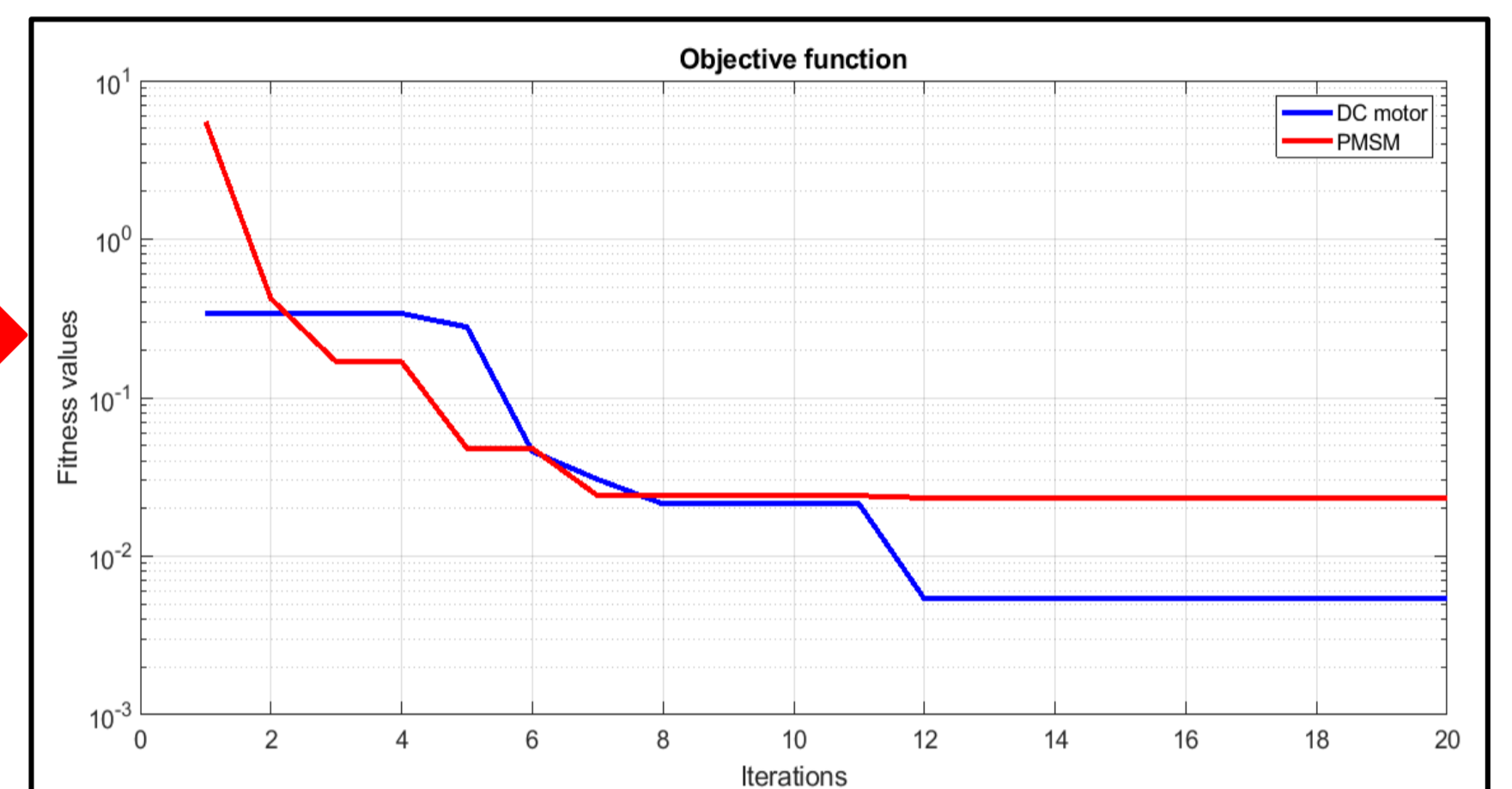

## Conclusion

The application of the Stochastic Fractal Search (SFS) Algorithm demonstrates its potential in optimizing PI controller parameters for both DC motors and PMSMs. While DC motors achieved better fitness values due to their simpler dynamics, PMSMs exhibited superior performance in key metrics such as rise time, overshoot, and overall control stability. These findings highlight the SFS algorithm's capability to enhance motor performance, particularly for complex systems like PMSMs, making it a promising tool for advanced electric drive applications where efficiency and precision are critical.

## Reference

[1] Salimi, H. (2015). Stochastic Fractal Search: A Powerful Metaheuristic Algorithm. *Knowledge-Based Systems*, 76, 1–18.