



Conference Proceedings Paper – Remote Sensing

A Mobile Vehicle Weight Sensor and its Application in Transportation

(Case Study: Municipal Solid Waste Collection Vehicles)

Mehran Safdar ^{1,*}

^{1,*}Science & Technology Town, Isfahan, Iran; E-Mail: safdar_mehran@yahoo.com;
Tel.: +98-31-33932188; Fax: +98-31-33932189.

Published: 6 June 2015

Abstract: In recent years, due to the expansion of the vehicles' transportation system and concerns about the lack of accurate calculations of vehicle weight, a system that is able to calculate the vehicle's weight at any moment, it seems necessary. Given that the transportation electronic management is related to the location and movement data of vehicles, information about movement, speed and time, traveled path, the weight sensors and fuel for the quick and timely decisions are required. Therefore the design and implementation of modern systems for monitoring and control of these devices to make quick decisions and plan codified is essential. In this paper firstly, the different ways of measuring the vehicle weight and the problems of each them has been described then the weight sensor device which is equipped with an AVL system, and its application in urban management (waste collection) has been described, finally, the advantages of this device have been proposed.

Keywords: Vehicle weight sensor, AVL System, Urban transportation system, municipal solid waste collection.

1. Introduction

Since the creation of the first human on Earth, business and transportation of goods through land and on the road has been a usual way. With developing the highway, transportation and business trade, vehicle weigh-in-motion technology has become a key technology and trend of measuring weight of the loads. Moreover, because of the strong competition between transport modes and companies, transportation management was improved, which has led to an increase in the numbers of fully loaded trucks and their gross weights. Recently, there have been a significant number of

vehicles illegally overloaded and the damage vehicles cause on the road is in direct proportion to the axle weight by 4th power. The overloaded transportation would greatly increase the cost for the pavement maintenance and repair, shorten the service life of pavement, even affect the traffic safety and capability. So it is imperative to build a weigh station to solve these problems. Traditionally the weights of vehicles were measured and collected by placing it on the scale while the vehicle is at rest. Weight information of vehicles acquired by static weighing (i.e. does not move) was a conventional method which was used widely these days. Though the precision of this way to measure the gross weight of vehicle is very high, there are many disadvantages of the method: it is not only expensive but also not possible to measure the weight of each axle separately. The most important is that it is inconvenient to weigh with stopping vehicles in some practical application. In this paper, have been tried to introduce vehicle weight sensor device which is equipped with an AVL system and the place and the role of these devices in urban transportation, especially municipal solid waste collection vehicles.

2. Problem statement

Today in most developed countries the mobile navigational systems is used as a powerful tool to monitor and track the navigational systems of bus, taxi, police, shippers, distributors, municipal waste collectors and so on. According to the development of the transportation system and lack of correct estimation of the weight of the load on the vehicle it has become a necessity to have a system that can measure the weight of the vehicle every moment, also the importance of electronic monitoring of the civil transportation system and due to the fact that most of the decisions of the executive managers and vehicle owner depend on the information about the location either mobile or stable. Mobility information of the vehicle is required. Meanwhile, the manner of movement, the traversed route, and the condition of weight and fuel sensors, mobility information is required to fast and accurate decision making. In many departments and organizations, especially municipalities that use vehicles, weighting of vehicle and the geographical location of them it will be very important, so, a system like AVL can transfer the weight of vehicle to central system online wherever the GPS is active. By putting the geographical information system together with navigational system of mobile vehicles, an information system can be produced in a way that the location of vehicles can be traced every moment on information system (Dynamic GIS).

3. Methods of measuring the weight of vehicle:

- Measuring directly
- Measuring indirectly

3.1. Measuring directly

Measuring directly is the way which measured and collected by placing the vehicle on the scale while the vehicle is at rest. Some disadvantages of this method was mentioned but the other disadvantage is that ,the sensors which are normally used for measuring have an overload capacity and more than this capacity causes pressure on the sensor, therefore it cannot illustrate the real weight of the load. According that the loads usually fall down from high height on the vehicle, this

hit on the sensor is usually 10 times more than its weight and it is natural that this amount of weight will not be tolerated by sensor. Therefore a system which be considered for measuring the weight of the load, must be able to tolerate this extra pressure. This point is the main advantage of the sensor which we described below.

3.2. Measuring indirectly

- Measuring distance by digital ruler
- Measuring angle change of spring
- Measuring side spring pressure on weight sensor

3.2.1. Measuring distance by digital ruler

In this way we can measure the weight changes of vehicle at any moment by putting a digital ruler between back chassis and axle of vehicle. This way has some problem such as:

- High price of digital ruler
- Shock and Moisture sensitivity

3.2.2. Measuring angle change of spring

Spring angle, changes with weight changes, so with using an angle measurement module, we can measure the weight changes of vehicle. Problem of this way is that these sensors' action is based on the magnetic changes of poles and if it is placed near power cable or metal, loses its precision.

3.2.3. Measuring spring pressure on weight sensor:

3.2.3.1. Components:

1. A base of weight sensor
2. A weight sensor capable of weighing up to 20 kilograms
3. A spring capable of increasing pressure up to 20 kilograms
4. A ball bearing placed on the spring
5. A device that converts the system's resistance to 1 to 10 volt
6. AVL devices
7. The central computer that calculates the voltage and changes it to a weight proportionate with the weight of the vehicle
8. Communication Cables(a medium to transfer data)
9. A data transfer system that provides communication between computer and sensor

Figure 1: Vehicle weight sensor device

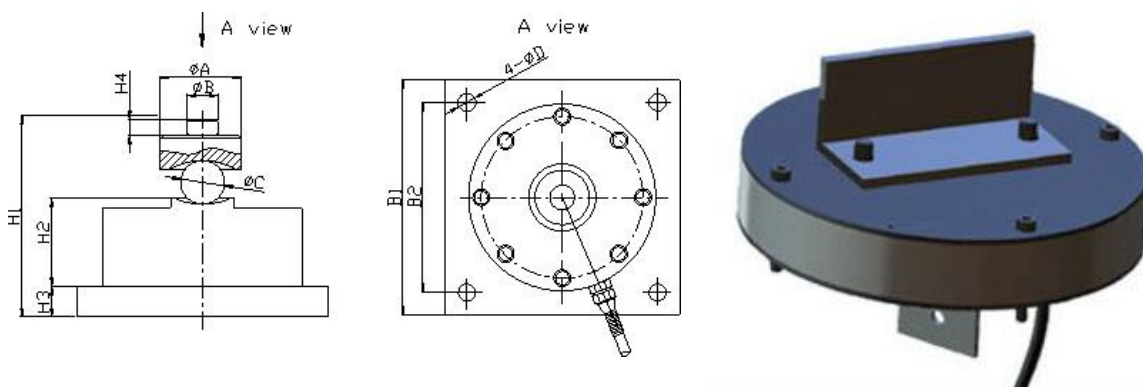

3.2.3.2. Operating mechanism of weight sensor device:

The weight sensor (20 kilograms) is attached to the base of the vehicle from one side and to the spring valid for 20 kilograms from the other side. The other side of spring is placed on the flat spring of the vehicle. When the weight of the vehicle increases, the spring is jammed and it produces a power towards the weight sensor and changes the output resistance. The pivot in the device changes the sensor resistance into voltage in a way that the pivot shows 1 voltage if there is no load on chassis and it shows 10 if there is the maximum weight on the chassis .This voltage is set on the AVL and it sends to the central computer via wireless communication network such as GPRS, 3G, Local wireless, dedicated wireless network, other wireless networks to the central server. The central server estimates the weight according to a calibration chart.

3.2.3.3. Benefits of measuring spring pressure on weight sensor:

- Pieces are cheap
- Low depreciation of device
- Accuracy and Precision

4. Device Specifications

- Safe and Nondestructive
- Waterproof and Shock absorber
- Small size
- Easy install on all kind of vehicle
- Accuracy and Precision with minimum error
- The vehicle load at an instant is computed by measuring changes in to vehicle suspension system.
- The changes in the vehicle suspension system are measured by a variation in pressure applied on the load cell in the weigh sensing device at an instant.
- The weight sensing device case a circuit board for measuring a pressure applied on the load cell and converting the applied pressure level into a resistance value.
- The weight sensor device is connected to the AVL system through a wired connection or wireless connection.
- The AVL is provided with a monitor to display the vehicle load and the vehicle location data simultaneously.
- The central computer receives the voltage data from the voltage conversion unit through the AVL system to calculate the vehicle load at an instant using a pre-calibrated chart.
- The central computer receives the vehicle location data and the voltage data from the AVL system to monitor a vehicle location and the vehicle load at any instant.
- The central computer receives a position data, and wherein the position data includes a longitude, latitude and altitude of the vehicle at any instant, a speed of the vehicle, bearing data and a time data from the AVL.

Table 2.Weight sensor Technical Parameter:

Sensitivity:	$(2.0 \pm 0.1\%) \text{ mV/V}$
Combined Error:	$\pm 0.02\% \text{ F.S}$
Zero Balance:	$\pm 1\% \text{ F.S}$
Input Resistance:	$750 \pm 5\Omega$
Output Resistance:	$702 \pm 2\Omega$
Insulation Resistance:	$\geq 5000\text{M}\Omega$
Operating Temp. Range:	$-30 \sim +70$
Maximum Safe Over Load:	$150\% \text{ F.S}$
Ultimate Over Load:	$300\% \text{ F.S}$
Element Material:	Alloy Steel, Stainless Steel

Sensor installed on the back chassis and axle of vehicle. The weight sensor measures the load/weight of the vehicle. The load/weight data obtained from the weight sensor i.e. "analog output sensor" shows the incoming pressure on the spring, of the sensor, resulted from the distance changes from the suspension system of vehicle. The load/weight data obtained from the weight sensor is transformed to the digital data by an Analog-to-Digital circuit. The system further comprises a microcontroller (central processor) for processing data received from various modules and sending or displaying the data to the users. The microcontroller receives data from the weight sensor installed in the vehicle, data from the positioning satellites and data from a dynamo of the vehicle.

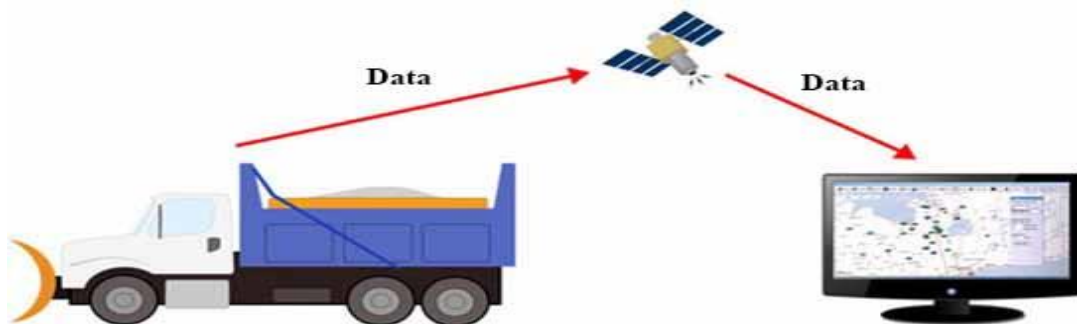
Figure 2. Central computer receives the data through the AVL system

The positioning data are checked at regular intervals such as every minute and are considered to device configurations. These configurations are done upon differences on at-least three parameters such as but not limited to: time, angle and distance. For example consider an example wherein if time change: 30 seconds, angle change:20 degree and distance change:500 meters are defined for a device, then the device analyses positioning data every one second and checks differences of time, angle and distance with previous data received. If each of these differences exceeds specified data in configurations, then new data together with obtained loading weight and status of vehicle engine are

packed in data packet. The packed data are further sent to three different outputs according to applied settings on the device.

The system comprises a weight sending device attached to a base of a vehicle, and wherein the weight sensing, device is load cell, a compression spring attached to the weight sensing device and to a suspension spring of the vehicle, a voltage conversion unit attached to the weight sensing device to convert and output resistance of the load cell into a voltage, an automatic vehicle location (AVL) system connected to the voltage conversion unit to receive the output voltage from the voltage conversion unit and a central server connected to the AVL to receive location data and the vehicle load at any instant is communicated simultaneously to driver of the vehicle.

A system and method is provided for measuring changes of vehicle suspension system in order to monitor changes of vehicle loading weight in various local and time situations and also checking driver's attitude toward road surface roughness. For this purpose, this system consists of two main parts: hardware and software. Hardware part is in control of measuring changes of suspension system and processing these data in order to gain vehicle loading weight. Concluded weight could be displayed to the driver on the LCD in vehicle cabin, or together with received data from positioning module (received from positioning satellites) including speed and position of vehicle and time in the form of package is saved offline on a memory or is sent via a wireless module to server software. All these data is parsed in server software and saved in position database, So that various reports required for driver and vehicle function and operation is generated by compounding data related to weight, position, speed and time.

Figure3 illustrates status of the vehicle and weight sensor online and point to point on the map for monitoring changes of vehicle loading weight data in various local and time situations by installing a weight sensor on the back chassis and axle of a vehicle.

Figure 3. The geographical position of municipal solid waste collection vehicle on the map



There is a need for an automatic vehicle load monitoring system and navigation monitoring system that can measure the weight of the vehicle at every moment. Further, there is a need for a modern system to monitor and control the vehicles for rapid decision making and lasting arrangement. Also there is a need for method for transferring data on the speed, location and other information regarding the vehicle.

These systems are efficient in tracking the mobile vehicle and showing them on maps inside the control center. The navigation system can be an intelligent tracking net via a telegraphic, connection between mobile vehicles and control center. Therefore, monitoring the situation, exact location,

speed, other information regarding each vehicle, ability to send and receive message, directing the vehicles to their destination, control on sensors (fuel, engine temperature, transferred weight via the vehicles, ...) in order to repair and mend based on the traversed route and to restrict the vehicles activities based on some defined rules such as forbidden areas, areas under inspection, etc. are feasible.

5. The importance of weight sensors in transportation

The amount of transferred load by vehicles and calculating the value of load has been of concerns of the managers of transportation system. There has always been a need for localized sensor with a reasonable price that can calculate the amount of load on the vehicle and provide it for the employer online. This sensor should come in a reasonable price, be easy to install, with high accuracy, be online, and be localized in order to meet the needs of transportation department. The importance of such a sensor has been felt in garbage collecting. Municipality employees collected garbage from the city. These employees are paid for every ton of garbage they collect. If they do not collect garbage, they collect bran and construction waste instead in order to make the collected garbage heavier. Table 3 has shown the relations between the amount of waste collected and price. Whatever the amount of waste increases, the price is multiplied by the larger number, so it is clear that drivers want to collect heavier garbages.

Table 3. The relation between the amount of waste collected and price:

Garbage (Ton)	Price(\$)
2	X
10	5 X
100	50 X
1000	500 X

If the municipality is equipped with such online sensor they would be able to know the amount of produced garbage and driver violations and exact information for metropolitan arrangements. Figures 4 and 5 have shown the time and amount of garbage which collected by drivers. The report as shown in figure 4 is resulted according to data received from weight sensor (changes of the suspension system of the vehicle) together with speed and geographical data of vehicle (received data from GPS). It is clear that in this case the driver did his job without any mistake; but Figure 5 illustrates the sudden change of weight sensor in two driftnet time which means that driver collect bran and construction waste instead of garbage.

Figure 4. Collecting and unloading garbage in normal way

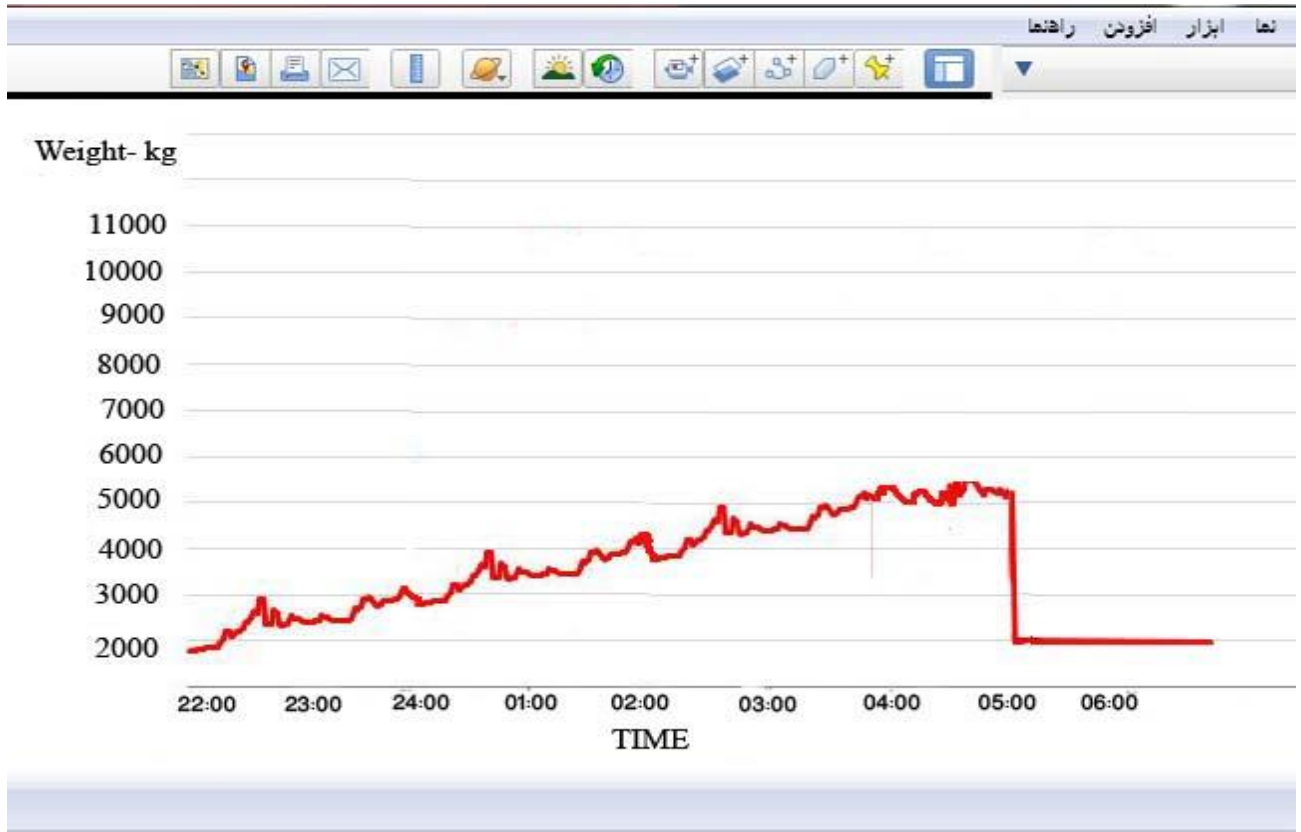
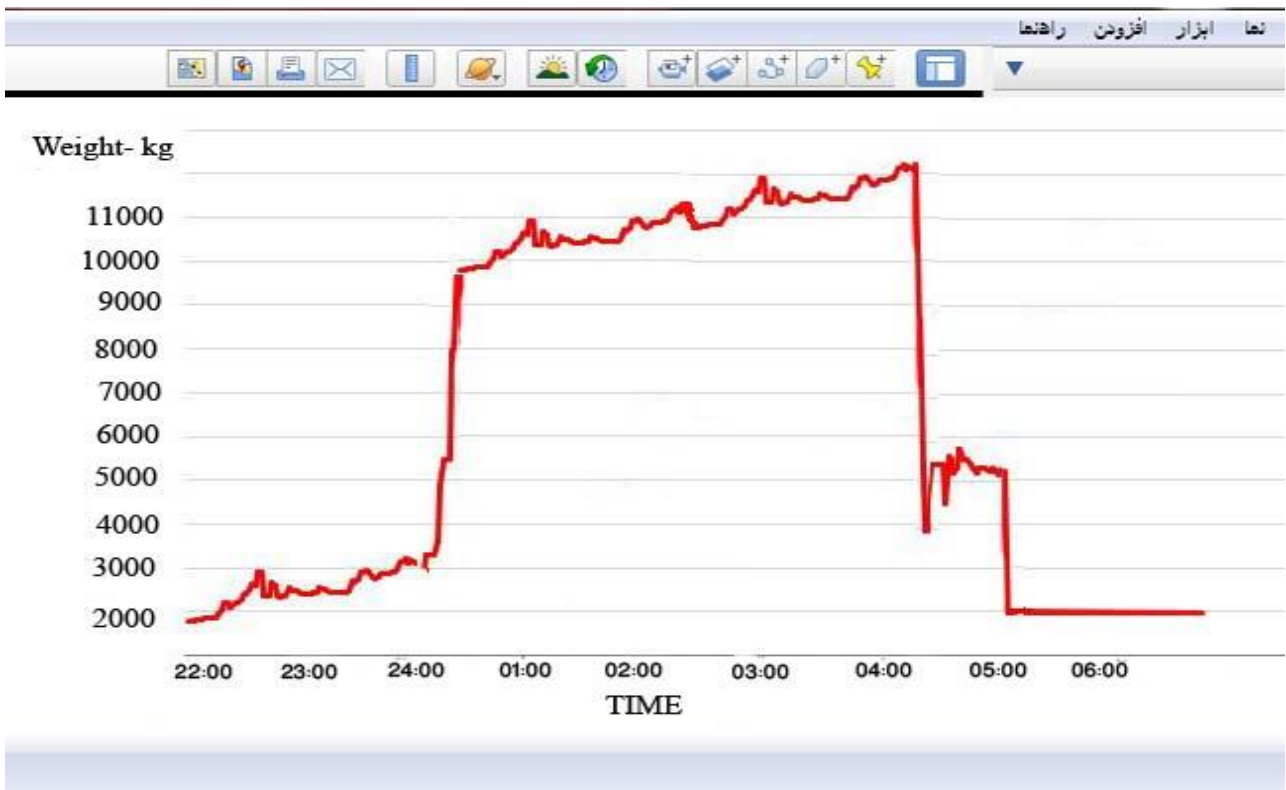

Figure 5. Collecting and unloading garbage in unauthorized loading way



These figures also can illustrate a synthetic diagram of speed and weight sensor data on time, in time of sudden change of weight sensor for constant amount of speed (nonzero) shows the occurrence of tension in the suspension system of the vehicle (due to road roughness and puddles). High speed and intense change show high tension and imprudence of driver in paying attention to vehicle during driving on road roughness's. Corresponding points of these diagrams with their related drawn points on the map is integrated for both the map and diagram, its corresponding point on the map is detected and is representative of road roughness location and also driver's disobedience. By the report as shown in figures, road roughness points could be recognized and could be used over time as a spatial data layer consisted of critical points on the road for all groups of vehicles.

A detailed report from function of weight sensor data is generated from the data saved/stored in the database of the central server. The aim of designing, the report is to compare general operation and function of fleets in various definable weight ranges for the weight sensor. The report would be designed upon the map and without a map. In map-based reports, the report is taken from one vehicle and following information is displayed for user: start to end time, average, sensor maximum and minimum, average and maximum of speed and passed distance.

Figure 6 illustrates system architecture for measuring changes in the vehicle suspension system for monitoring changes of vehicle loading weight in various local and time situations and also checking driver's attitude toward road surface roughness. The system comprises at-least three positioning satellites, one or more load carrying vehicles adopted with a system for measuring changes of suspension system and processing the data in order gain vehicle loading weight, a central server for sorting position and vehicle load weight and wireless communication network for sending position and vehicle load weight from the vehicle to the central server. All the data is parsed in central server and saved in apposition database of central server, so that various reports required for driver and vehicle functions and operation is generated by compounding data related to weight, position, and time. The report comprises the status of the considered vehicle and weight sensor online and point to point on the map, grid and diagram. The report is generated upon user request and receives all points in a time interval and displays them on the map. Blow of the map, a "line chart" is drawn in one panel and information grid in another panel. In information grid, all descriptive data received from the device such as weight, speed, data of receiving data, departure angle and vehicle's status (turn on/shut off) and all other received data. There is complete integration between the chart, grid and map items, so that point is selected by clicking on each of the at-least three parts: map event, chart point or grid row. In one panel, speed chart and received data from weight sensor are drowning, so that comparison between simultaneous changes of the weight sensor and speed of the vehicle is possible and easy.

Figure 6. Report of sensor function toward geographical region

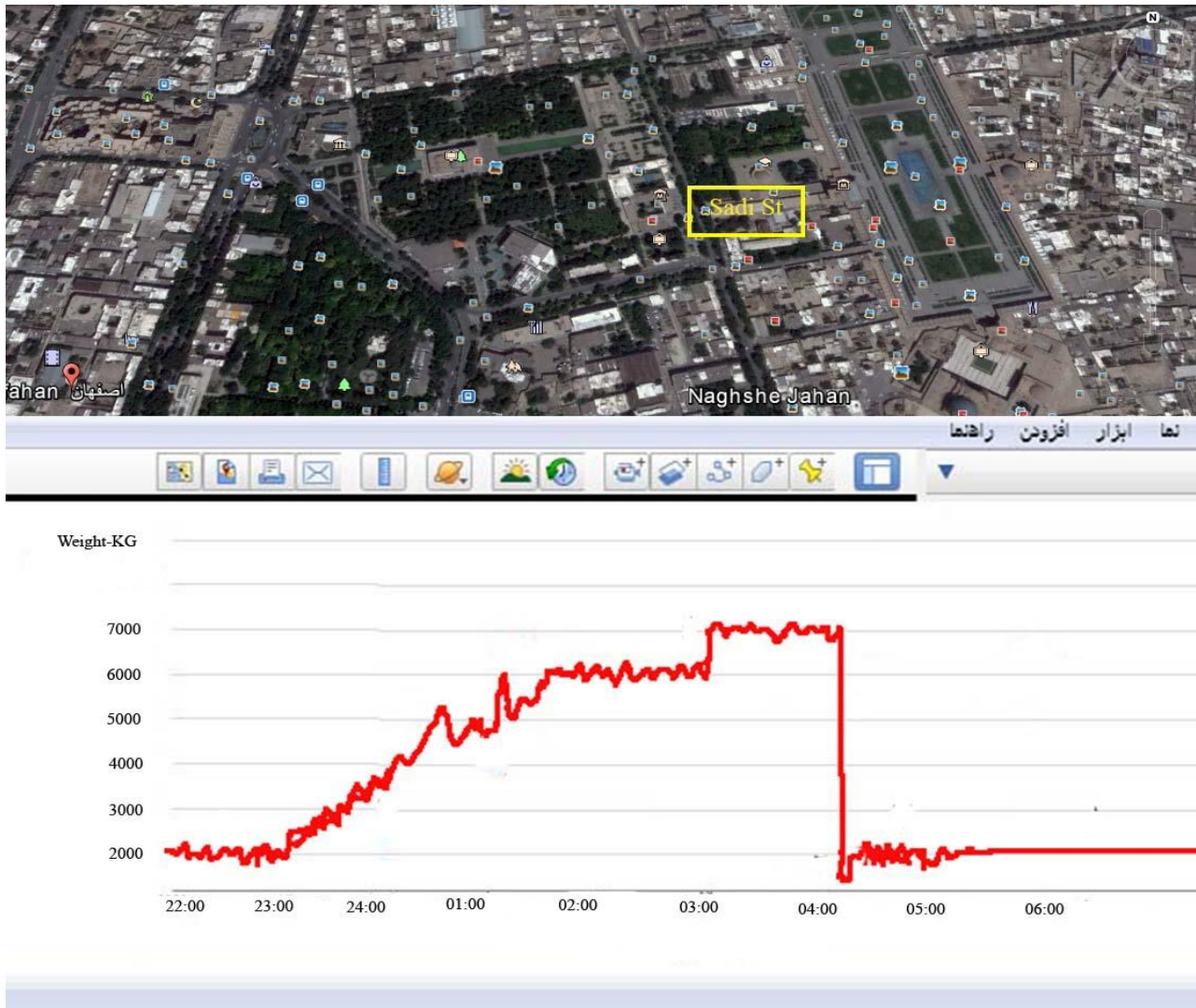

This figure illustrates a report of sensor function toward geographical region. The user requests in socket module or software installs in the central server for vehicle function in regular polygon geographical region and a specific time interval. The socket module or software installed in the central server display following results: time of entering to region, time of exit from region, presence time of vehicle in region, amount of weight resulted from sensor in time of entering and exiting, average-maximum-minimum of weight amount in presence time of vehicle in the region, passed distance in that time interval. In order to draw a regular polygon in the socket module or software installed in the central server, one map panel is designed; so that the user draws the desired polygon just by click on the map and continue the drawing by double click on the map. Then, a form is opened, the user types the name of the desired region, so a specific region by known name is drawn for user, this name will be used later for choosing that region.

Innovations in this project are included:

- The vehicle load at an instant is computed by measuring changes in a vehicle suspension system.
- The changes in vehicle suspension system is measured by a variation in pressure applied on the load cell in the weight sensing device at an instant.

- The weight sensing device is connected to the voltage conversion unit through wired connection.
- The central computer receives the voltage data from the voltage conversion unit through the AVL system to calculate the vehicle load at an instant using a pre-calibrated chart.
- The central computer stores the vehicle load data, the vehicle location data and speed of the vehicle at any instant in a memory along with a time stamp.

Usage of weight sensor on different vehicles:

- Carrying fuel and acid vehicles
- Municipal waste collected vehicles
- Soil and construction waste collected vehicles
- Cargo vehicles

4. Conclusions

There are various methods for measuring the weight of the load of the vehicles, like scales but there are many disadvantages in this method: it is not only expensive but also not possible to measure the weight of each axle separately. Therefore making a weight sensor that can measure the weight of the vehicle with the extra load, seems to be necessary.

Many equipment have been designed for automatic vehicle load monitoring system and navigation monitoring system, but the system which we designed has these qualities: a weight sensing device attached to a base of a vehicle, and wherein the weight sensing device is a load cell; a compression spring attached to the weight sensing device and to a suspension spring of the vehicle; a voltage conversion unit attached to the weight sensing device to convert an output resistance of the load cell into a voltage; an automatic vehicle location data and a voltage conversion unit; and a central server connected to the AVL to receive a vehicle location data and a voltage data for computing a vehicle load at an instant; wherein the vehicle location data and the vehicle load at any instant is communicated simultaneously to a driver of the vehicle.

In municipality which is equipped with such online sensor, they would be able to know the amount of produced garbage in different days and seasons (these data can be save in database of central computer) and would be able to use this information for metropolitan arrangements, also would be able to recognize and confirm the driver's disobedience.

Finally, safe and nondestructive, waterproof and shock absorber, small size, easy install on all kind of vehicle, accuracy and precision with minimum error, are some advantages of this device that justify the economic value of this device.

References and Notes

1. Basem Almadani, Shehryar Khan, Tarek R. Sheltami, (2014)," *Automatic Vehicle Location and Monitoring System based on Data Distribution Service*",procedia Computer Science, Volume 37,Pages 127-134.
2. Christine M. Johnson, Edward L. Thomas, (2000),"*Automatic vehicle location successful transit applications* ", Federal Highway Administration, USA.
3. Hull, Bret, Bychkovsky, Vladimir, et al, (2010),"*A Distributed Mobile Sensor Computing System*", Boulder, Colorado, USA.
4. Lu Cheng, Hongjian Zhang, Qing Li, (2011)," *Design of a Capacitive Flexible Weighing Sensor for Vehicle WIM System*", Sensor magazine.
5. Luca D'Acierno, Armando Carteni, Bruno Montella (2009), "*Estimation of urban traffic conditions using an Automatic Vehicle Location (AVL) System*", European Journal of Operational Research, Volume 196,Issu2,pages 719-736
6. Ramesh B. Mall, Amlan Sen, Norman W. Garrick, (2008)," *A Special Fiber Optic Sensor for Measuring Wheel Loads of Vehicles on Highways*", Sensor magazine.
7. Wenbin Zhang, Chunguang Suo, Qi Wang, (2009)," *A Novel Sensor System for Measuring Wheel Loads of Vehicles on Highways*", Sensor magazine.

© 2015 by the authors; licensee MDPI, Basel, Switzerland. This article is an open access article distributed under the terms and conditions of the Creative Commons Attribution license (<http://creativecommons.org/licenses/by/4.0/>).