

An IoT-Enhanced Life Cycle Assessment Framework for Continuous Environmental Impact Monitoring in Solar Energy Systems

Victor José Olivero, Carlos Arturo Robles, Mario José Callejas, John Alexander Taborda, Laura Alejandra Chia
Facultad de Ingeniería - Universidad del Magdalena, Vicepresidencia Técnica - Agencia Nacional de Hidrocarburos (ANH)
volivero@unimagdalena.edu.co, croblesa@unimagdalena.edu.co, mariocallejasjc@unimagdalena.edu.co, itaborda@unimagdalena.edu.co, laura.chia@anh.gov.co

CORE MESSAGE: Dynamic LCA becomes operational and trustworthy when real-time IoT monitoring transforms static environmental assessment into continuous intelligence.

INTRODUCTION & AIM

The ESG Trust Gap & The Problem

- Static LCA Limitations: Current environmental assessments rely on retrospective, aggregated datasets.
- Contextual Blindspots: Fail to capture operational variability.

The Transition Challenge

- Expanding solar energy requires trust among public institutions, developers, and communities.

Aim of the Study

- Propose an IoT-enhanced dynamic Life Cycle Assessment (dLCA)

METHOD

Edge/Cloud IoT Architecture

- Edge Devices: Capture and pre-process local environmental and operational data in real-time.
- Cloud Services: Aggregate, harmonize, and feed processed telemetry into the dynamic assessment workflow.

Dynamic LCA (dLCA) Integration

- Replaces static snapshots with dynamic updates of inventory parameters.
- Ensures strict data provenance, temporal consistency, and interoperability.

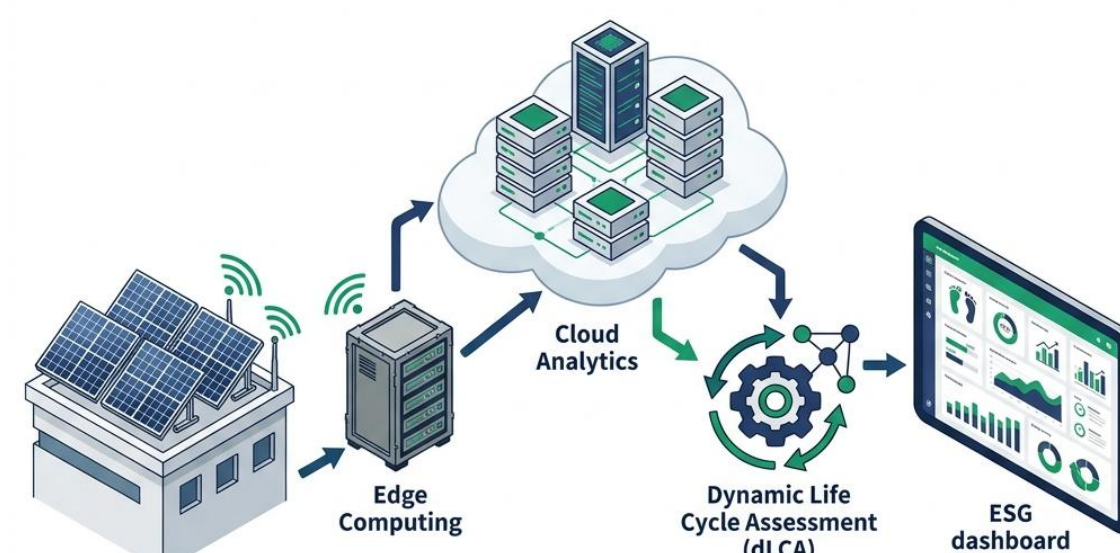

Static LCA		IoT-Enhanced dLCA	
Temporal Resolution	Retrospective, aggregated, time-invariant datasets.	Temporal Resolution	Dynamic updates of inventory parameters throughout key project phases.
Contextual Accuracy	Blindspots regarding operational variability.	Contextual Accuracy	Captures real-time, context-specific dynamics.
Data Provenance & Trust	Quality challenges in emerging economies.	Data Provenance & Trust	Auditable transparency for public institutions, developers, and communities.

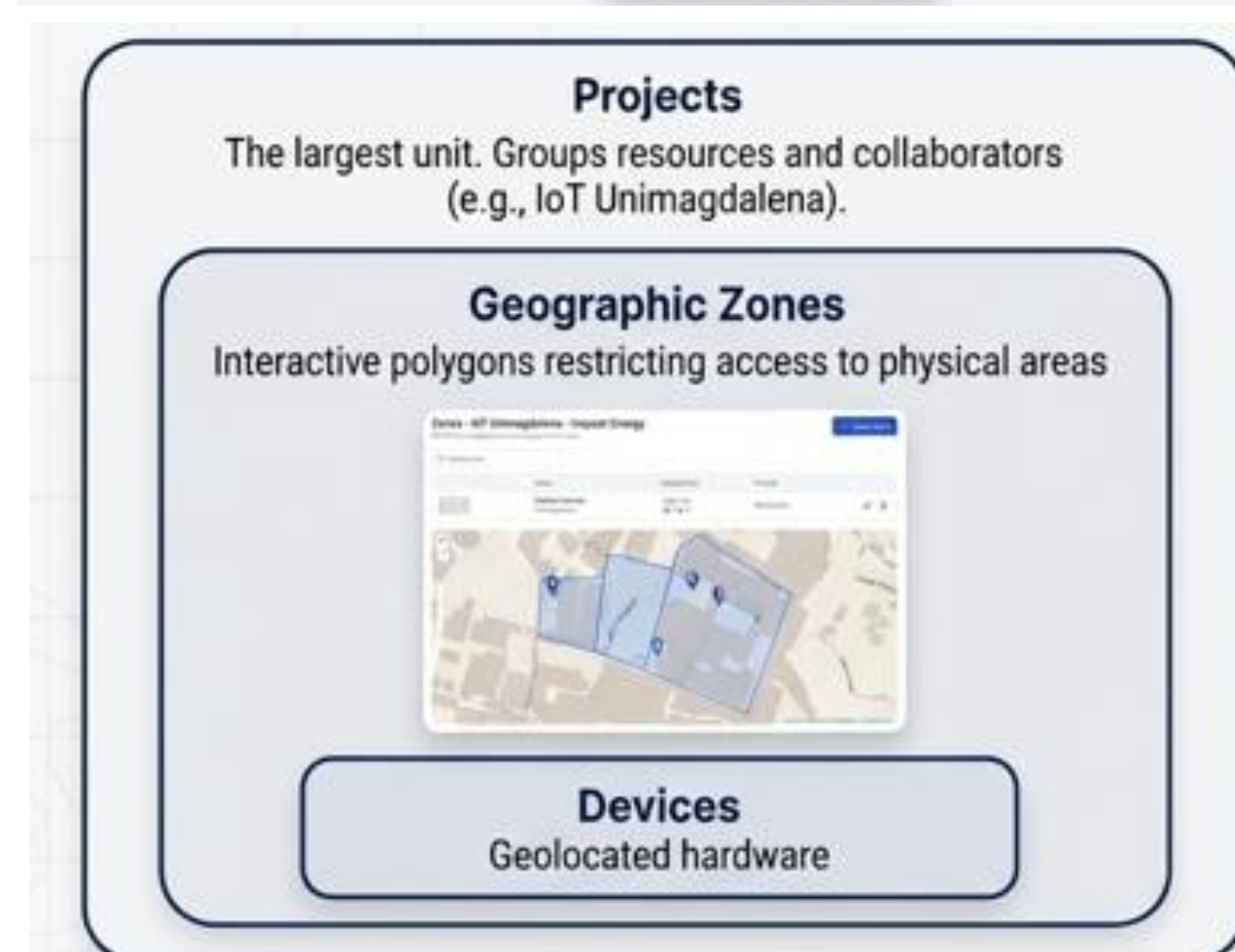
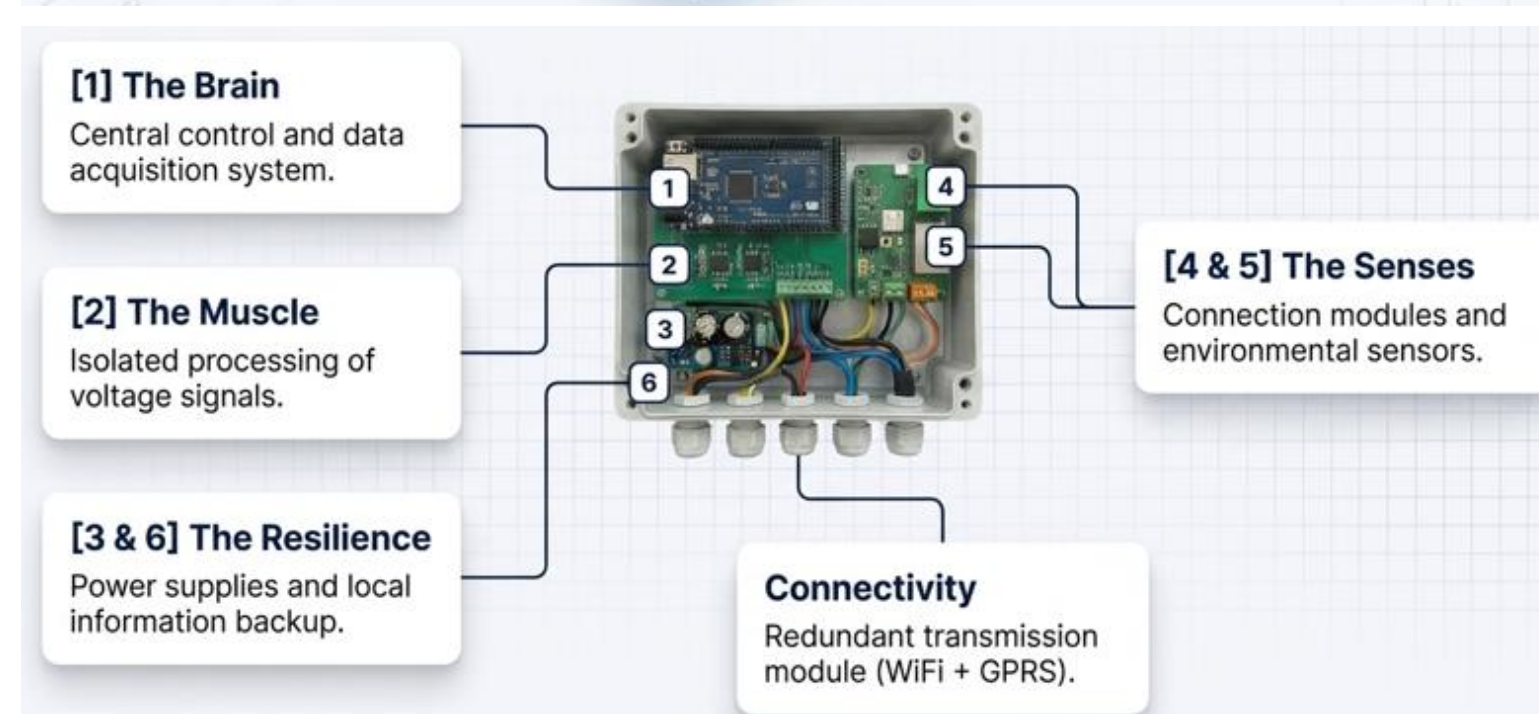
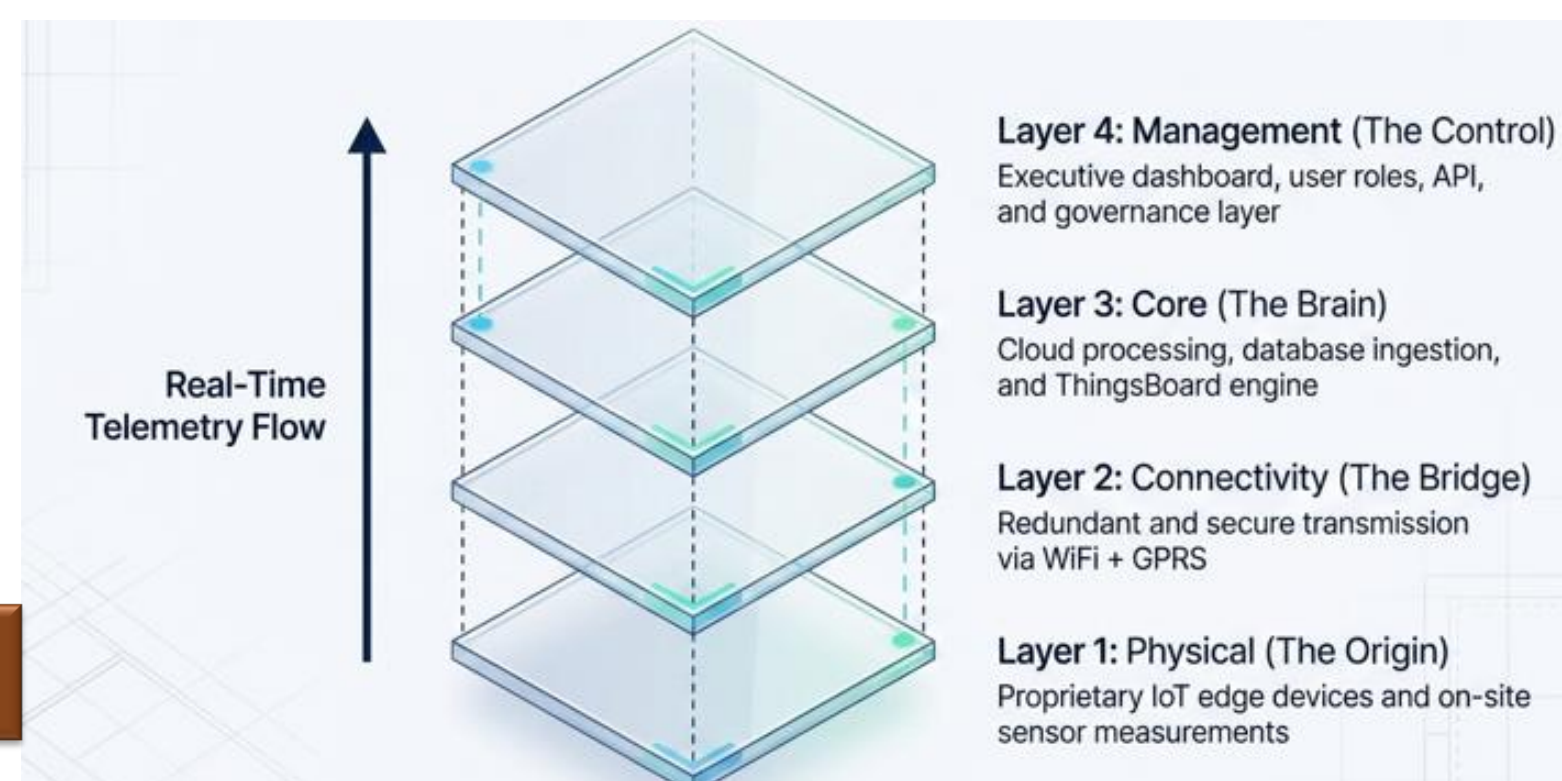

RESULTS & DISCUSSION

Platform Operationalization & Dashboards

- Fully operationalized within the IMPACT Energy.CO digital platform.
- Enables robust tracking of environmental performance over time.

Governance & Colombian Case Study

- Tested in a real-world Latin American context.
- Key Outcome: Overcomes limits of temporal resolution and dramatically increases stakeholder trust and data transparency.

CONCLUSION

- Evolution of Practice: Advances LCA from retrospective analysis to dynamic monitoring.
- Traceability: Improves data quality control and transparency.
- Decision-Making: Provides a transferable methodological foundation for governance.

FUTURE WORK

- Scaling platform for fully quantitative dLCA assessments.
- Enterprise integration and journal publication.

ACKNOWLEDGEMENTS:

• Funded by Agencia Nacional de Hidrocarburos (ANH), Vicepresidencia Técnica (Contract No. 515 of 2025) executed with Universidad del Magdalena.

