

Dynamic Modeling Analysis of a Doubly-fed Induction Generator Based Wind Energy System

Sardorjon Samiev^{*1}, Shokhabbos Doliev¹, Javlonbek Khamraev¹, Golibjon Makhmatqulov², Khurshid Yusupov¹

¹Department of Information Technologies in Industry and Tourism, Shahrizabz Faculty of Food Engineering, Karshi State Technical University, Shahrizabz 181306, Uzbekistan.

²Department of Economics, Faculty of Pedagogy, University of Economics and Pedagogy, Karshi 180100, Uzbekistan.

*Corresponding author: sardorjonsamiyev95@gmail.com

INTRODUCTION & AIM

Wind energy has become one of the most promising renewable energy sources because of its wide availability, environmental sustainability, and declining installation costs. Among variable-speed wind turbine technologies, the Doubly-Fed Induction Generator (DFIG) is widely adopted due to its high efficiency, flexible speed operation, and reduced converter rating. In a DFIG system, the stator is directly connected to the grid, while the rotor is controlled through a back-to-back AC/DC/AC converter, enabling independent regulation of active and reactive power with lower converter capacity than full-scale converter systems.

Despite these advantages, maintaining stable operation during start-up and under varying wind conditions remains a significant challenge. Fast stabilization of stator current, effective DC-link voltage regulation, and improved transient performance are essential for reliable integration with external power supply systems and modern microgrids. Advanced vector control strategies combined with Space Vector Pulse Width Modulation (SVPWM) provide accurate decoupled control of converter currents and enhance the dynamic performance of DFIG-based wind energy conversion systems.

The aim of this study is to develop and validate a comprehensive MATLAB/Simulink model of a DFIG-based wind energy conversion system operating together with an external power supply. The proposed model integrates the wind turbine aerodynamic subsystem, the DFIG electromechanical model, and coordinated rotor-side and grid-side converter controllers based on stator-flux-oriented vector control and SVPWM. The system is designed to achieve stator current stabilization within 0.01 s while maintaining a stable DC-link voltage, ensuring reliable and efficient operation under transient conditions.

METHOD

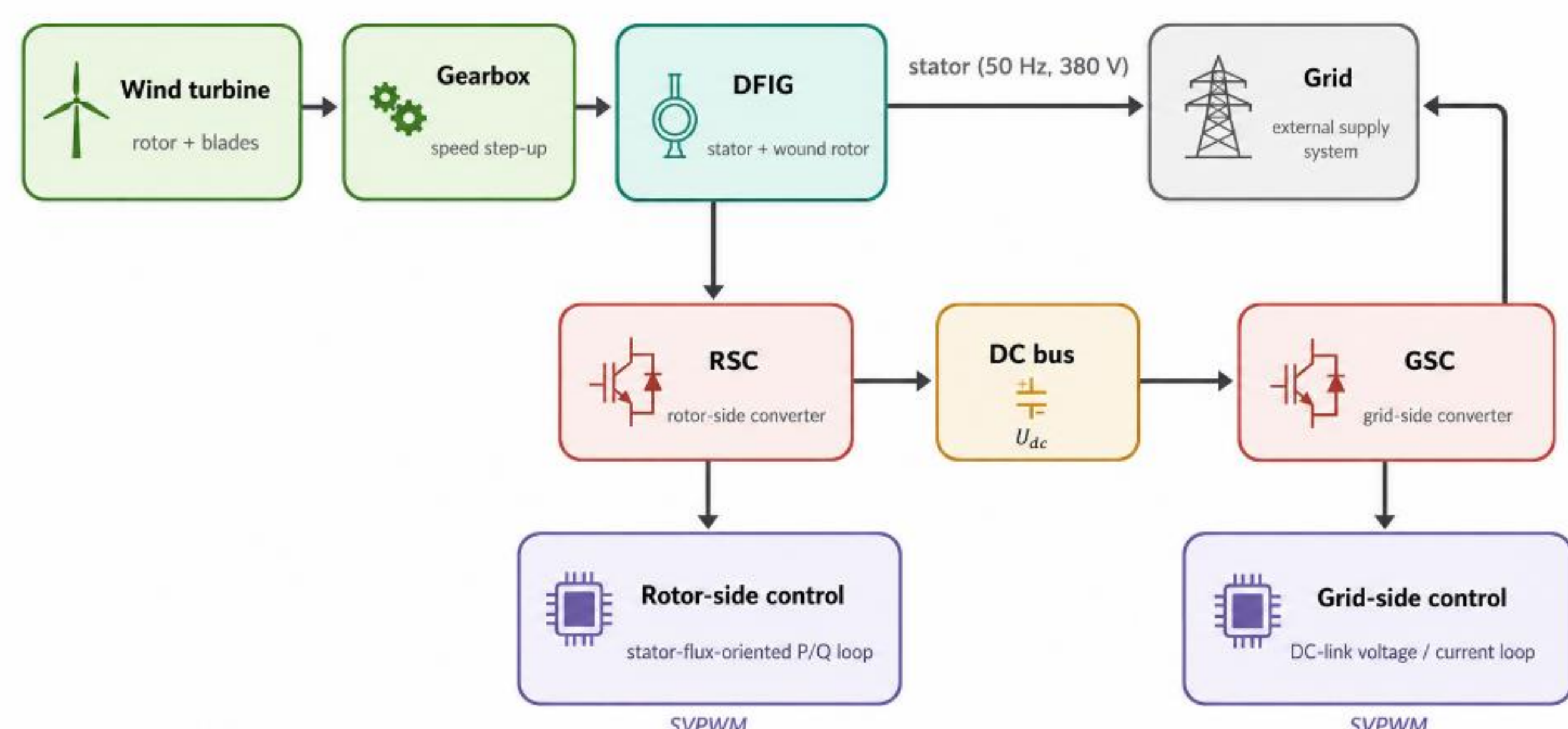

Figure 1. Structure of the DFIG wind energy conversion system and its rotor-side / grid-side control loops

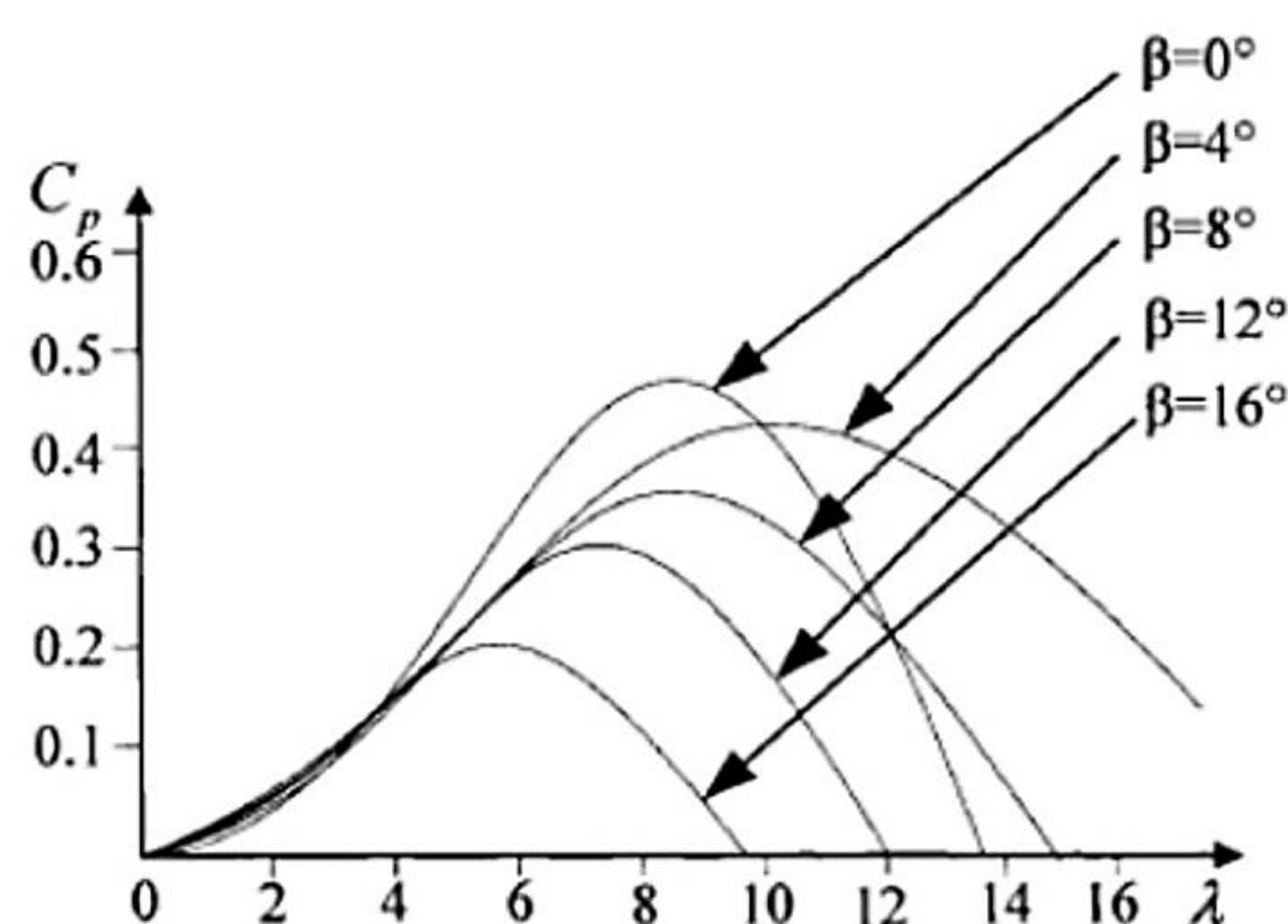

Figure 2. Power coefficient C_p as a function of the tip-speed ratio λ for pitch angles $\beta = 0 \dots 16^\circ$.

Aerodynamic Model

$$P_{wt} = \frac{1}{2} \rho \pi R^2 v^3 C_p(\lambda, \beta)$$

Power coefficient $C_{p,max} \approx 0.43$ at optimal tip-speed ratio $\lambda_{opt} \approx 9$. Rated output of 100 kW at 10 m/s yields minimum rotor radius $R \approx 11.08$ m.

Table 1. Parameters of the simulated wind turbine and doubly-fed induction generator

Parameter	Value
Rated power	100 kW
Rated stator voltage	380 V
Rated stator frequency	50 Hz
Stator resistance	0.26 Ω
Stator leakage inductance	0.3 mH
Rotor resistance	0.27 Ω
Rotor leakage inductance	0.3 mH
Mutual inductance	27.5 mH
Moment of inertia	0.2 kg·m ²
Minimum rotor radius (calculated)	11.08 m

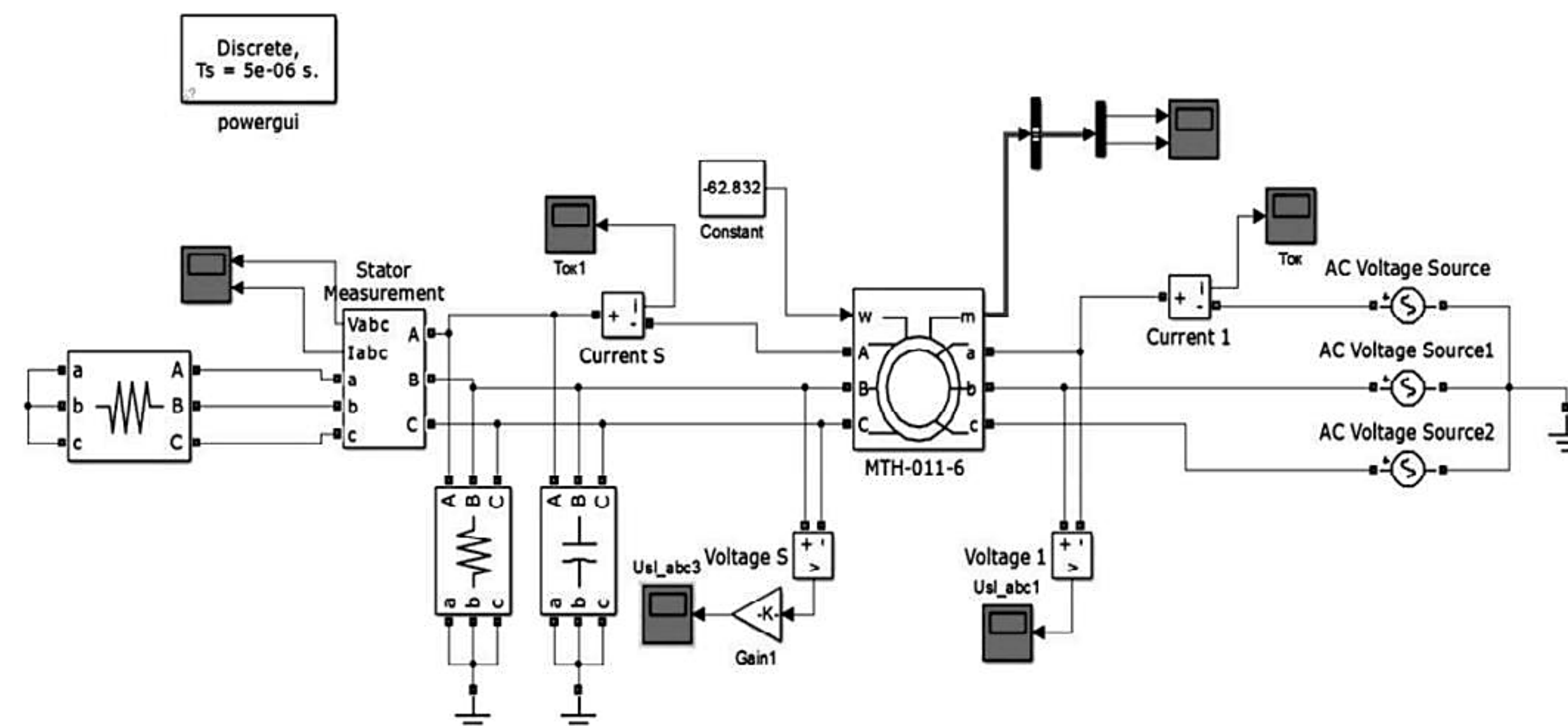

Figure 3. Model MATLAB/Simulink of a double-fed generator

RESULTS & DISCUSSION

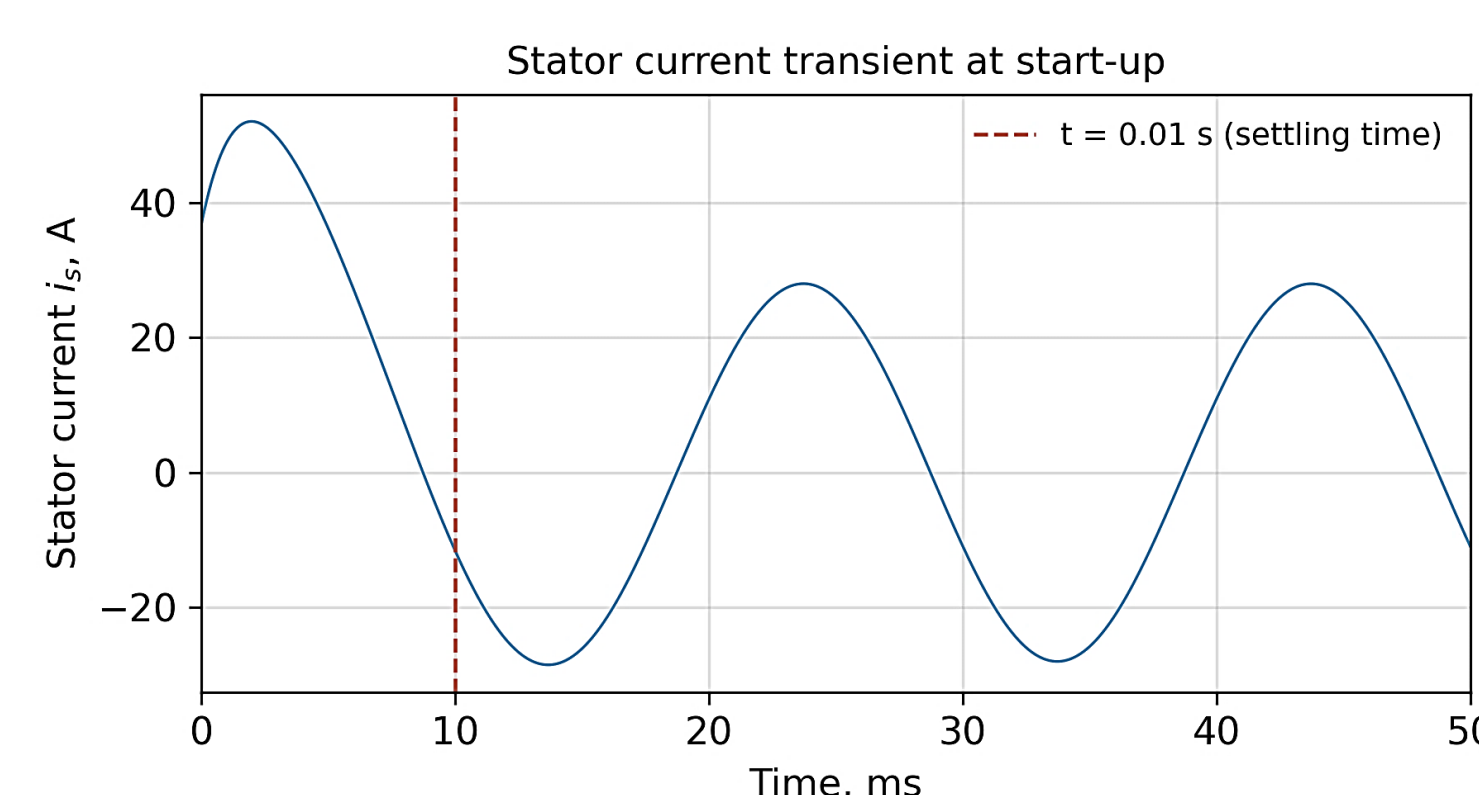

Figure 4. Characteristic shape of the stator current transient during the first 50 ms after start-up; the vertical line marks the $t = 0.01$ s settling-time requirement

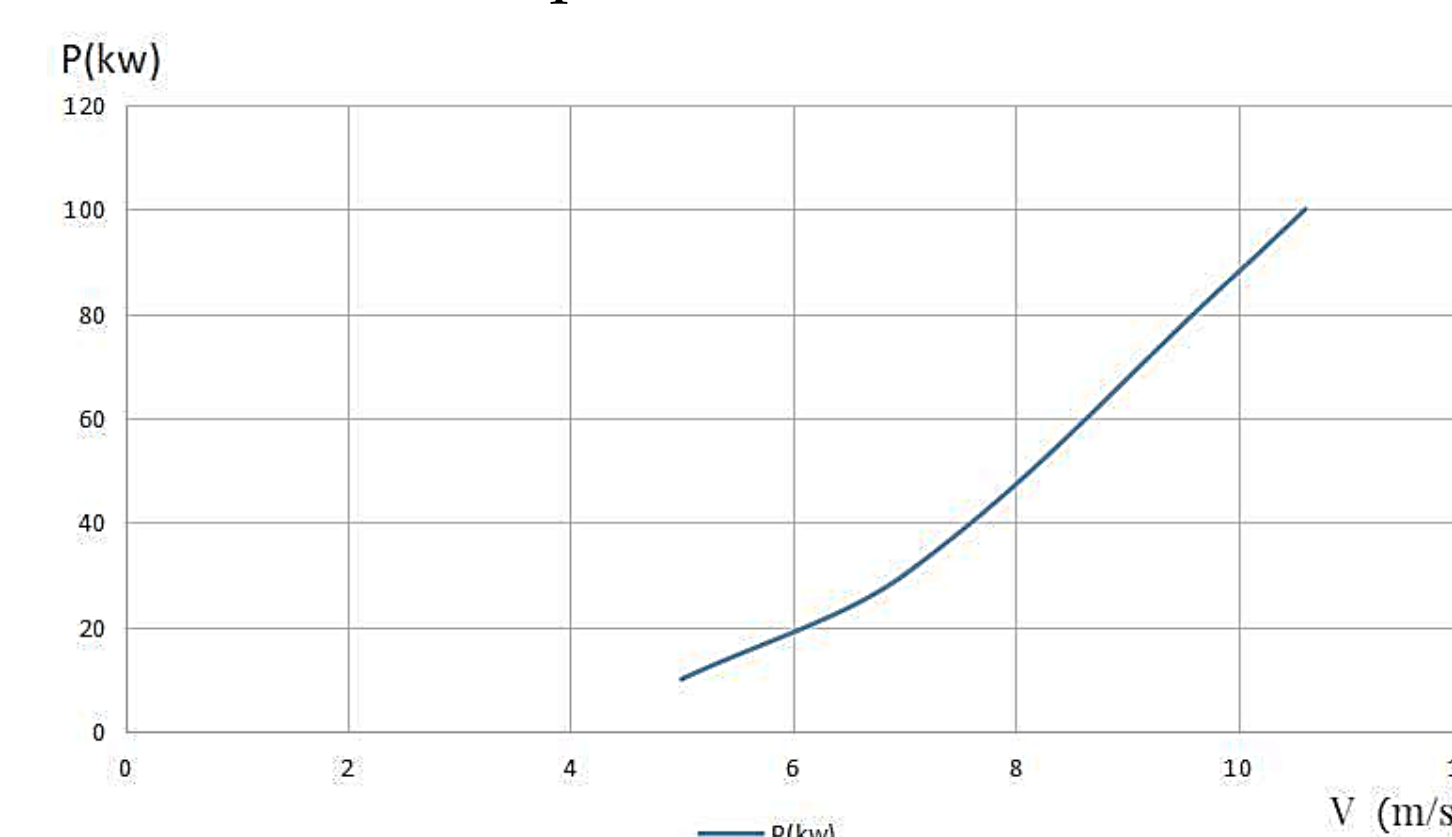

Figure 5. Relationship between the total active output power P (kW) and wind speed V (m/s) obtained from the simulation

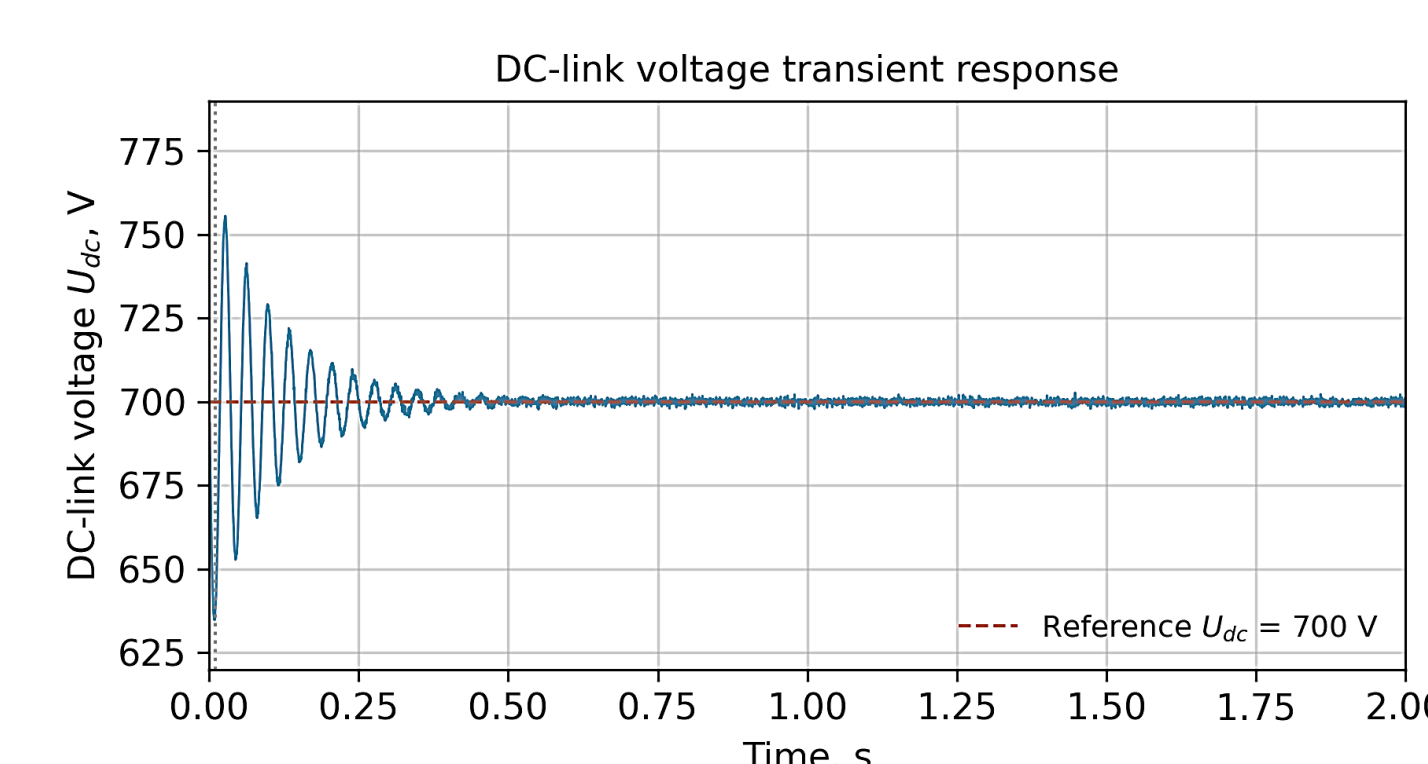

Figure 6. Simulated DC-link voltage waveform; the voltage stabilizes at approximately 700 V after an initial damped oscillatory transient of about 0.5 s

Stator current settles to steady-state 50 Hz sinusoidal waveform within 0.01 s — technical requirement fully satisfied across all wind speed operating points (5, 7, 10.6 m/s).

Output follows cubic wind-speed law: at 5 m/s ≈ 10 –11 kW; reaches rated 100 kW at 10.6 m/s. MPPT tracks $C_{p,max} = 0.43$ at $\lambda_{opt} \approx 9$ across full speed range.

DC-link voltage stabilizes at ~ 700 V after a well-damped oscillatory transient of ~ 0.5 s. Outer DC-link voltage PI loop provides adequate damping for reliable converter operation.

CONCLUSIONS

This study developed and verified a MATLAB/Simulink model of a Doubly-Fed Induction Generator (DFIG)-based wind energy conversion system with a back-to-back converter and advanced vector control strategies. The integrated aerodynamic turbine model with MPPT and the dq0-frame DFIG model ensured accurate representation of system dynamics.

Simulation results confirmed stable and efficient operation: the system successfully achieved rated power of 100 kW at rated wind speed, with proper tracking of maximum power point. The stator current reached steady-state within 0.01 s, while the DC-link voltage stabilized around 700 V after a short transient, demonstrating effective control performance.

Overall, the proposed control structure (stator-flux-oriented rotor-side control and grid-voltage-oriented grid-side control with SVPWM) provides a robust solution for stable operation of DFIG-based wind energy systems, suitable for microgrid and renewable integration applications.

REFERENCES

- Cai, H., et al.: Cooling system and control method of the room-type SVG at the Inner Mongolia wind farm. Science, Technology and Economy of Inner Mongolia, no. 7, pp. 74–75 (2013).
- Zhang, X.: Research on grid-connection control based on back-to-back converters. Communication Power Technology, vol. 7, pp. 12–14 (2016).