

Conference Proceedings Paper

# LPE Application Technique for Obtaining of Thin Film Semiconductor Compounds

Vadym Tsybulenko, Stanislav Shutov and Sergey Yerochin \*

V. Lashkaryov Institute of Semiconductor Physics, NAS Ukraine, lab. N23, 76/78 Zavodskaya St., Kherson, 73008, Ukraine; lab23@ukrpost.net

\* Correspondence: sergey.yerochin@gmail.com

**Abstract:** A new technique of liquid phase epitaxy has been proposed in this work. It allows to eliminate known disadvantages of liquid phase epitaxy by creating short-time contact between a substrate and a solution-melt, as well as due to segmental deposition of an epitaxial layer over the working substrate surface. The short-time of the contact is achieved by the means of Ampere force acting on the solution-melt. And the contact itself between the substrate and the solution-melt is realized pointwise (or segmentally) over the substrate surface using the scanning principle. The new technique was named "scanning liquid phase epitaxy". One of the modifications of device realization of the technique proposed has been considered and its principle of operation has been described. Preliminary theoretical investigations and experimental processes of semiconductor epitaxial layers obtaining have proved principal operational capability of the new technique. The technique developed allows to obtain thin and ultrathin epitaxial layers on the substrates of very large area which is limited only by the growth equipment size.

**Keywords:** liquid phase epitaxy; Ampere force; point deposition; segmental growth; thin films; growth equipment

---

## 1. Introduction

Fabricating of thin and ultrathin films as well as periodic layers by liquid phase epitaxy (LPE) is a complicated problem from the viewpoint of homogeneity of the layers obtained as well as their reproducibility. All the variants of LPE have similar factors affecting the quality, size and composition of the layers being deposited. Namely:

- the temperature regime instability at the growth interface due to the heat transfer process inertia of the heating assembly;
- the influence of elastic energy of a strained epitaxial layer during the heterostructure formation [1];
- a depletion of one or more components of a solution-melt in the growing vessel [2];
- dragging over a solution-melt from one growing vessel into another [2];
- convective streams in a solution-melt [3];
- diffusion of solution-melt or epitaxial layer components into a solid phase [4].

In the work [5] the authors have formulated basic requirements to the new LPE technique. Its implementation will make it possible to obtain more perfect thin and ultrathin films as well as periodic layers.

Based the analysis of the work [5] we proposed the new technique of liquid phase epitaxy – scanning liquid phase epitaxy [6].

## 2. Scanning Liquid Phase Epitaxy

### 2.1. The Technique Description

Operating principles of the technique are as follows. A solution-melt in the homogenization container (vessel) at the homogenization temperature is brought into contact with a cooled substrate for a short period of time. After growing of just a part of the layer or the whole one, the substrate is cleansed immediately of the solution-melt, which is returned to the homogenization container. The special feature of the process is that the wetting of the substrate and/or its cleansing of the solution-melt is realized by using Ampere force which acts on the solution-melt as the electric current and the magnetic field pass through it in certain directions [7].

The other feature of the LPE technique developed is that the substrate and the solution-melt are contacted pointwise (or segmentally) over the substrate surface by means of mechanical scanning device. Here the moving part could be either the substrate or the growing vessel.

### 2.2. The Apparatus Description

The apparatus for realization of the technique proposed represents the gas camera where the growing vessel is placed. The growing vessel control unit may be located separately and could be connected with the growing vessel through the interface at the one of gas camera panels.

Figure 1. shows the growing vessel allowing to realize the new technique.

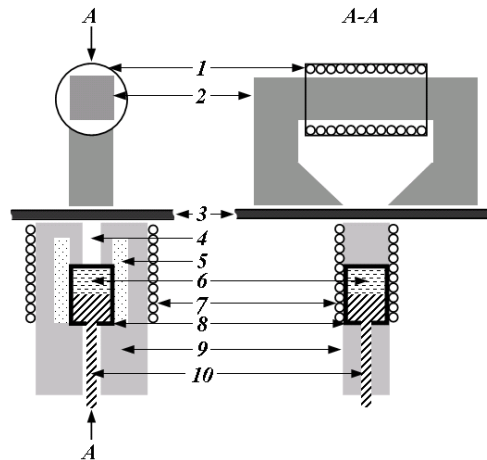

**Figure 1.** The growing vessel for scanning LPE: 1 – coil, 2 – magnetic conductor, 3 – substrate, 4 – growth capillary, 5 – high-temperature insulator (ceramics), 6 – solution-melt, 7 – heater, 8 – homogenization container, 9 – electrode, 10 – piston.

The growing vessel could be also realized differently. For example, magnetic conductor could be located under the substrate or both the solution-melt and the magnetic conductor may be located over the substrate. If the Ampere force and its direction are controlled only by the magnitude and the direction of the current, then it is possible to use permanent magnets for creation of the magnetic field. Thus, a versatility of the technique proposed is provided due to utilization of various combinations of the construction elements.

The growing vessel proposed is equipped with specially configured electrodes as shown in Figure 1. It allows to create current and magnetic field gradients in the solution-melt: maximum current and maximum magnetic field are at the growth interface. Thus Ampere force acting on the solution-melt is maximal at the interface between the substrate and the solution-melt as well. In turn, the value of current and the magnetic field magnitude are chosen to provide the Ampere force

exceeding over adhesive force between the solution-melt and the substrate taking into account the solution-melt gravity force. It is important that the heating assembly heats only the solution-melt and partially the electrodes. This makes the heating processes to be much less inert.

It is important that in the design presented the homogenization container and the growth capillary are separate elements. This allows to remove an oxide film from the solution-melt surface after the homogenization stage during moving the solution-melt into the growth capillary. Since the heater is small-sized and is located on the growing vessel there are no special temperature requirements to the gas camera material. Thus it could be manufactured using available low-temperature materials. Basic requirement to the gas camera is that it should have enough room for the growing vessel and for the substrate of a desired area.

### 2.3. *The Technique of Epitaxial Layers Growing*

Every act of growing of either a part of epitaxial layer or entire layer (over the whole area or just a portion of substrate surface) consists of five stages:

Stage 1. Wetting the substrate by the solution-melt. The solution-melt is in the homogenization container at the homogenization temperature. The substrate has a lower temperature. The solution-melt is moved from the homogenization container into the growth capillary with the help of the piston – Figure 1. A current is supplied to the solution-melt simultaneously with the magnetic field in the direction providing Ampere force to be guided towards the interface between the solution-melt and the substrate.

Stage 2. Growing of a part of the epitaxial layer or the entire layer. During the contact between the solution-melt and the cooled substrate the deposition of the epitaxial layer of a certain thickness occurs after the time period chosen. The thickness of the layer grown at the given temperature could be controlled by the contact time between the solution-melt and the cooled substrate and/or by the value of the substrate cooling.

Stage 3. Removing the solution-melt from the substrate. It is realized by instantaneous changing of the direction of Ampere force acting on the solution-melt. For example, it is possible to change instantly the direction of the current through the solution-melt. The magnitude of Ampere force is calculated so as to exceed the adhesion/cohesion force and taking into account the gravity force acting on the solution-melt.

Stage 4. The solution-melt return into the homogenization container. This could be achieved by various ways depending on the growing vessel configuration chosen. For example, for the growing vessel design proposed (see figure 1) the solution-melt is returned back to the homogenization container under the gravity force and/or Ampere force (the piston must be at the lowest position).

Stage 5. Homogenization of the solution-melt in the homogenization container. It is realized at a homogenization temperature during certain calculated amount of time.

## 3. Results and Discussion

The results of the modeling of heat and mass transfer processes in the growing vessel for scanning LPE developed are shown in Figure 2.

As it can be seen from the graphs in Figure 2 there is a principal possibility of obtaining of thin and ultrathin layers by the technique developed.

We manufactured the pilot apparatus for scanning LPE. Functionality of the mechanisms of substrate wetting and cleaning of a solution-melt by the Ampere force is established. Preliminary experimental investigations of the systems GaAs/GaAs and Ge/GaAs (Ga solution-melts) showed the principal possibility of growing the epitaxial layer by this technique.

In comparison with known LPE technique variants [8], scanning LPE provides the duration of a short-time contact between the solution-melt and the substrate less than a second. According to our calculations such a short time value makes it possible to reduce the thickness of uncontrollably

grown epitaxial layer by more than the order of magnitude as the temperature instability of the heating assembly is eliminated, and to avoid the formation of convective streams.

In contrast to known pulse variants of LPE [9, 10], in the proposed technique the heating assembly heats the solution-melt directly while the substrate is located at the independent temperature zone. Owing to this, the heating and cooling time of the substrate is shortened from tens of minutes up to few seconds. Both the short-time contact between the solution-melt and the substrate as well as the low heat process inertia allow to reduce by one order and more the depth of diffusion of the solution-melt components and the components of epitaxial layers grown further into the bulk of substrate. In addition, segmental epitaxial layers grown on the substrate surface do not require continuous heating as it takes place in other LPE variants. This affects the diffusion depth as well if there remains a thin layer of a solution-melt on the substrate after the growth process.

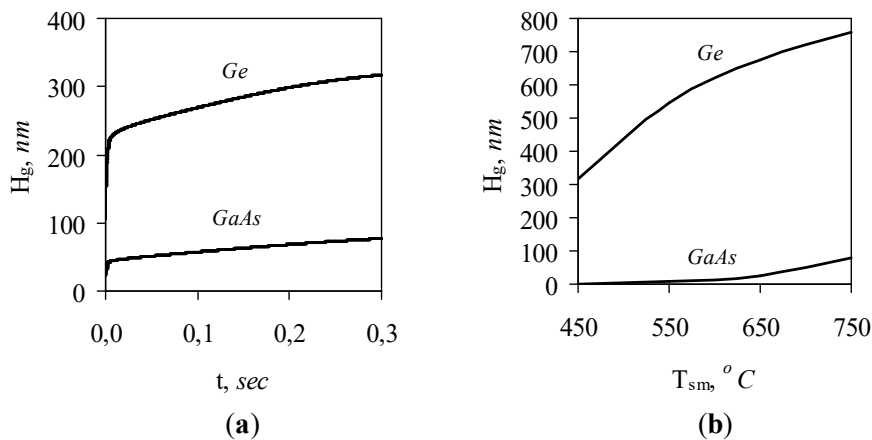

**Figure 2.** The dependence of maximum thickness  $H_g$  of the epitaxial layers grown on the contact time between the solution-melt and the substrate (Ge layer from Ga-Ge solution-melt, solution-melt temperature  $T_{sm}=450$   $^{\circ}C$ , substrate temperature  $T_s=27$   $^{\circ}C$ ; GaAs layer from Ga-As solution-melt,  $T_{sm}=750$   $^{\circ}C$ ,  $T_s=266$   $^{\circ}C$ ) (a). The dependence of maximum thickness  $H_g$  of the epitaxial layers (Ge and GaAs) grown within 0.3 s on the solution-melt initial temperature  $T_{sm}$  (b).

The substrate cleaning of the solution-melt is more rapid and more controllable in comparison with other methods due to the electrical process used for Ampere force creation. Also it is possible to cleanse the substrate of the solution-melt totally depending on the wetting angle between the solution-melt and the substrate.

Initial substrate overcooling before the contact with the solution-melt allows to avoid uncontrolled phase equilibrium shift and to create the conditions of instantaneous crystallization of the epitaxial layer, i.e. without dissolving of previously grown layers. In addition, when the solution-melt returns to the homogenization container after every growth act there is no solution-melt depletion by the components being deposited.

Segmental growth of continuous epitaxial layer over the substrate surface makes it possible to use very large area substrates.

#### 4. Conclusion

The new technique of liquid phase epitaxy – scanning LPE allowing to realize short-time contact between a solution-melt and a substrate was developed. The principal possibility of thin and ultrathin layers obtaining was shown.

## References

1. Kuznetsov V.V.; Lunin L.S.; Ratushnyj V.I. *Heterostructures based on quaternary and quinary solid solutions of III-V compounds*; SKNC VSH: Rostov-on-Don, Russia, 2003; pp.66–75.
2. Andreev, V.M.; Dolginov, L.M.; Tretijakov, D.N. *Liquid-phase epitaxy in semiconductor device technology*; Soviet radio: Moscow, USSR, 1975; p.57,70.
3. Litvin, A.A.; Maronchuk, I.Ye. The peculiarities of epitaxial layers growing from a solution-melt in bounded volume. *J. Crystallogr.* **1977**, *22*, 23–25.
4. Sokolov, I.A. *Calculations of semiconductor technology processes*; Metallurgiya: Moscow, Russia, 1994; pp.6–14.
5. Tsybulenko, V.V.; Shutov, S.V.; Maronchuk, A.I. The analysis of thin and ultrathin layers obtaining by liquid phase epitaxy. In Proceedings of the XVth international scientific-practical conference “Modern information and electronic technologies”, Odessa, Ukraine, May 26–30, 2014, V.II, p.132.
6. Tsybulenko, V.V.; Shutov, S.V.; Yevdokimov, O.V.; Boskin, O.O. The method of epitaxial layer obtaining from the liquid phase, Patent UA 93097 U, Filed: Nov. 14 2013, Appl. No.: u 2013 13247; Date of Patent: 25 September 2014.
7. Tsybulenko, V.V.; Shutov, S.V.; Yerochin, S.Yu.; Boskin, O.O. “The method of substrate wetting and cleaning from a solution-melt in liquid-phase epitaxy”; Patent UA 115873 C2, Filed: July 28 2014, Appl. No.: a 2014 08609; Date of Patent: 10 January 2018.
8. Krapukhin, V.V.; Sokolov, I.A.; Kuznetsov, G.D. Physical and chemical fundamentals of semiconductor materials technology; Metallurgiya: Moscow, USSR, 1975; pp. 336–345.
9. Kulutkina, T.F.; Maronchuk, I.Ye.; Shorokhov, A.V. Growing of submicron layers by pulse cooling of a saturated solution-melt. *Tech. Phys. Lett.* **1995**, *21*, pp.1–5.
10. Abramov, A.V.; Deryagin, N.G.; Tretijakov, D.N.; Faleyev, N.N. Investigation of parameters of GaAs layers grown on Si substrates by liquid phase epitaxy. *Tech. Phys. Lett.* **1993**, *19*, 45–49.



© 2018 by the authors; licensee MDPI, Basel, Switzerland. This article is an open access article distributed under the terms and conditions of the Creative Commons by Attribution (CC-BY) license (<http://creativecommons.org/licenses/by/4.0/>).