



UNIVERSIDAD ESTATAL AMAZÓNICA
Educación con excelencia académica para formar profesionales de la más alta calidad

MODEC 03 | International Workshop of Natural Products and Agro-Industrial Processes In Ecuadorian Amazon Region

Preliminary study of caffeine extraction from *Ilex guayusa* L. leaves using supercritical carbon dioxide

Pablo Londoño-Larrea (palondono@uce.edu.ec)^a, Santiago Zapata (gszapata@uce.edu.ec)^a, Mishell Lara-López (malara@uce.edu.ec)^a, Estefanía Villamarin-Barriga (jevillamarin@uce.edu.ec)^a

^a Research Area, Chemical Engineering Faculty, Central University of Ecuador. Ciudadela Universitaria Ritter S/N y Bolivia, 170521, Quito, Ecuador. Phone: +593 22544631

Graphical Abstract

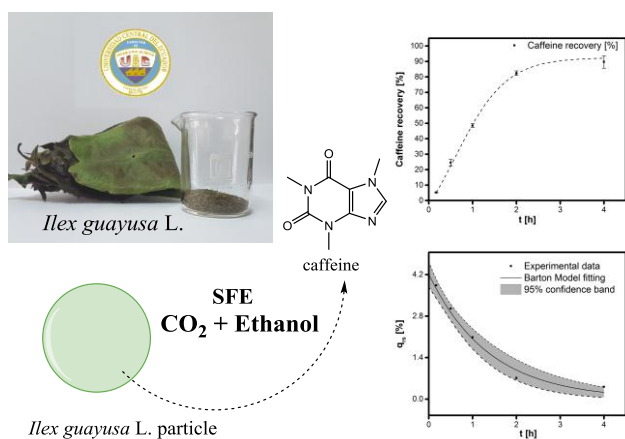

Abstract.

Caffeine (1,3,7 - trimethylxanthine) is a natural molecule present in a variety of plants, seeds or fruits, standing out in coffee, tea, mate, cola nuts, cocoa and guarana. It is widely used in different industries, acting as a stimulant for respiratory and central nervous systems. *Ilex guayusa* L. is located in the Amazon region of Colombia, Ecuador and Peru. Plant leaves present alkaloids such as caffeine and theobromine. In this work, extraction of caffeine from *Ilex guayusa* L. leaves using supercritical carbon dioxide (SCCO₂) was studied. The overall caffeine recovery from plant matrix was determined as a function of time (0.17, 0.5, 1, 2 and 4 h) at the same extraction conditions (23 MPa and 328 K). Ethanol as cosolvent was introduced in the extraction vessel to soak the vegetable material before SCCO₂ was

pumped. Cosolvent to solvent ratio remained constant in each experiment (3.5 g of ethanol / 100 g of SCCO₂). The highest caffeine recovery 89.7% was obtained after four hours of dynamic extraction. Barton model was used to analyze the extraction kinetics, data was successfully fitted ($R^2=0.974$) and diffusion coefficient was determined using model assumptions. Information here is presented for the very first time, is useful to predict extraction yields and to promote further research with this natural material.

Introduction

Ilex guayusa L. from the family Aquifoliaceae, is located in the Amazon region of Colombia, Ecuador and Peru. It can reach an average of 10 m height and present a multitude of stems with heights from 2 to 15 cm. [1]. Plant leaves present alkaloids such as caffeine and theobromine, with stimulating properties that can reduce fatigue and stress. Recently, ethanolic extract of *Ilex guayusa* L. leaves also showed to have estrogenic benefits in rats [2].

Caffeine (1,3,7 - trimethylxanthine) is a natural molecule present in a variety of plants, seeds or fruits standing out in coffee, tea, mate, cola nuts, cocoa and guarana [3]. It is used in pharmaceutical, food and cosmetic industries, acting as a stimulant for circulatory, respiratory and central nervous systems, as well as acting as a vasodilator and diuretic [4].

Traditionally, caffeine is extracted at lab scale using solid-liquid extraction with pure solvents (water, benzene, chloroform, trichloroethylene, dichloromethane, acetone, methanol, ethanol and acetonitrile) [5], some of them harmful to health [6]. Nowadays, more advanced extraction methods and techniques have been developed; for example: electrospray ionization ion mobility spectrometry ESI-IMS [7], liquid-liquid dispersed extraction [8], extraction by column chromatography with elution gradient [9], ultrasound-assisted extraction [10], microwave-assisted extraction [11] and supercritical fluid extraction (SFE) with supercritical CO₂. The last one, is a viable alternative to organic solvents, offering many advantages such as non-toxicity, solvent-free products and high selectivity in caffeine removal. Several works about SCCO₂ decaffeination of different vegetal matrix, such as coffee beans [12], cocoa butter [13], guarana seeds [14] and mate tea leaves [15], have been reported before. In fact, the extraction of caffeine with SCCO₂ is one of the most well-known commercial examples of SFE processes [16]. Additionally, many patents related with decaffeination of tea and coffee, where extraction of caffeine was carried out by different layouts have been published [17-20]. Moreover, in different countries, several large-scale plants have been designed for processing coffee, tea, and hops, and for spices and flavor extraction [21].

For determining caffeine solubility from green tea leaves in SCCO₂, variables such as pressure (15, 25, 35 MPa) and temperatures (313, 323, 333 K) were tested, 25 MPa and 333 K those which allowed 3.11% of caffeine extraction [22]. In the same way, it was possible to obtain a maximum recovery (84%) when using 373 K, 30 MPa and 197 kg CO₂ / kg of coffee husks [23]. Additionally, low solubility of caffeine in non-polar solvents such as CO₂ has prompted research into other solvents to improve solubility. For this reason, polar nature co-solvents were added to increase process efficiency. Studies using isopropanol and ethanol in CO₂ (mixed solvents), identified caffeine solubility increase using 10% to 90% ratios of ethanol in CO₂ [22]. Addition of co-solvent promote an increase in pressure and critical temperature of the mixture, and consequently the solubility of caffeine increases favorably with the addition of ethanol [24]. In fact, it had been shown that the addition of ethanol allows to improve the extraction times, decreasing from 7 to 2 hours maintaining similar yields [25,26]. SFE is a widely used environmental friendly technique. The effect of different cosolvents with SCCO₂ extraction of caffeine from green tea leaves was modelling based on mass transfer and time optimization [27]. So far, no works related with carbon dioxide SFE caffeine extraction from *Ilex guayusa* L. have been published.

Materials and Methods

Materials

As raw material, *Guayusa illex* leaves directly recollected from natural habitat were dried at ambient temperature on laboratory benches. Dried *Guayusa illex* leaves (GL) were ground in Retsch ZM-200 ultra-centrifugal mill, to an average diameter of 0.14 ± 0.49 mm, determined using a Retsch camsizer. Bed porosity was determined using information from real and apparent densities. Total content of caffeine in GL was determined. For this purpose, 1 g of GL were extracted at 365 K with 250 mL of water in a conventional Soxhlet apparatus. Three extraction cycles were performed to ensure maximum yield and this procedure was done by triplicate. Total content of caffeine in GL determined was 4.05 ± 0.35 %, and it was similar to reported before. [37]

Procedure

The supercritical CO₂ extraction apparatus used was an Applied Separations SPE-ED as shown in Figure 1. The system consists in a CO₂ cylinder, coupled to a piston pump. Compressed air was used to pressurize the CO₂. The pressurized gas was connected directly to a 500 ml high pressure vessel designed for working pressures up to 69 MPa and 493 K inside an oven. A pump is included in the system and coupled to the vessel for co-solvent supply (1-12 ml/min). A depressurization system was connected at the exit of the vessel. Flow rate was controlled with a needle valve and a flow-meter included in the apparatus. Pressure and temperature were controlled with a precision of ± 0.01 MPa and ± 0.1 K, respectively.

The extraction procedure consists of several steps. First, the vessel was filled with 3 ± 0.04 g of GL and glass beads were added to fill the residual volume of the vessel. After the vessel had been closed, V1 and V2 valves were closed while V3 valve was opened until the required amount of co-solvent was dosed into vessel. The oven temperature was set at 328 K, and vessel temperature was controlled until it reaches the equilibrium. After that, V3 restrict the flow of co-solvent and 23 MPa pressurized CO₂ filled the vessel. At the time that pressure remained stable, dynamic extraction started. V4 admitted flow over V5 valve, that was as opened as 4 l/min was measured in the flow meter. The condition was maintained until the desired time of extraction was completed. Depressurization process was done with V3 completely closed until the pressure was 4 MPa, and after that, V4 directs the flow to the exhaust line. Collected extract was mixed with water to reach 50 ml of final solution that was analyzed by HPLC and GC/MS.

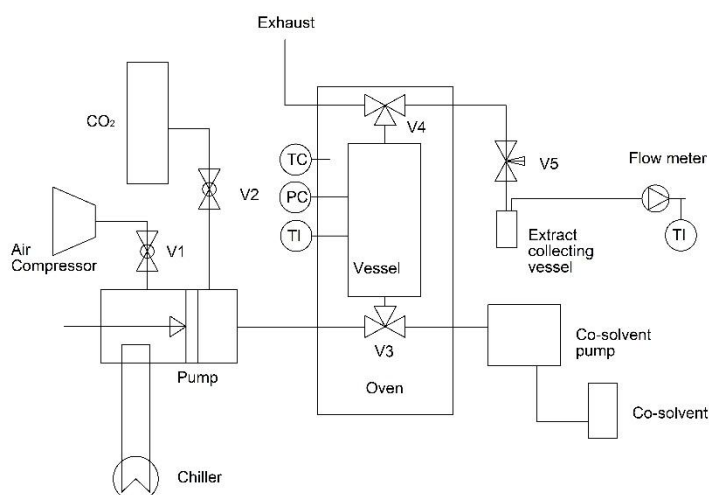

Figure 1. Schematic representation of supercritical CO₂ extraction apparatus. Temperature controller, TC; temperature indicator, TI; pressure controller, PC.

Operating conditions

Based on experimental information available in the literature, the extraction conditions were selected to be constant at 23 MPa and 328 K. At this conditions, high caffeine solubility in SCCO₂ was expected [22,28]. A minimum particle size (0.14 mm) was selected to minimize the diffusion distance and maximize contact area. CO₂ flow rate was set to 0.31 kg/h (4 l/min). Considering works related with caffeine SFE extraction, where yield and selectivity were improved when ethanol was added from 1 to 15 % [32–36], cosolvent to SCCO₂ ratio was set to 3.5 g of ethanol / 100 g of CO₂ in each experiment. In order to understand process kinetics, different times of extraction (0.17, 0.5, 1, 2 and 4 h) were analyzed.

Kinetic model

Previous works related with kinetics of SFE extraction had been published. An empirical model published by Barton et. al. (1991) [38], assumed proportionality between extraction rate of oleoresin and the concentration left in the vegetable matrix.

$$q_{rs} = q_0 \exp(-kt) \quad (1)$$

Where, q_0 was the initial concentration (%) of extractable compounds and q_{rs} was the concentration left in vegetable matrix. Also, assuming internal diffusion as the controlling step, kinetic constant k was defined as:

$$k = DA/Vz \quad (2)$$

Where, D was the solute diffusion coefficient (m^2/s), A/V the surface to volume ratio (m^{-1}) and z the diffusion distance (radius of each particle) (m). A/V ratio was estimated by [29]:

$$\frac{A}{V} = \frac{6(1 - \varepsilon)}{dp} \quad (3)$$

Where, dp was the particle diameter and ε is the bed porosity. Analytical solutions were calculated using OriginPro® 2015 Software. Model fitting was compared with experimental data according to the average absolute relative deviation (AARD).

$$AARD = \frac{1}{N} \sum_{i=1}^N \left(\frac{|q_{rs,exp}(t_n) - q_{rs,mod}(t_n)|}{q_{rs,exp}(t_n)} * 100 \right) \quad (4)$$

Where, $q_{rs,exp}(t_n)$ was the concentration of caffeine left in GL after an extraction time n , obtained experimentally, and $q_{rs,mod}(t_n)$ was the concentration of caffeine left in GL after an extraction time n , predicted by the model.

Extract characterization

Main components of each extract were determined using an Agilent 7820A GC coupled to Agilent 5977 MSD. Extract in methanol was injected (1 μ l) in DB-5MS column (30 m x 250 μ m x 0.25 μ m) set at 323 K for 3 min, and then heated to 553 K with 5 K/min rate. Inlet was configured in split-less mode at 498 K. Helium was the carrier gas at 1 ml/min flow rate. MSD parameters were as follows: Ion source

temperature 503 K, ionization voltage 70 eV, quad temperature 423 K, mass scan range: 50-550 mass units.

Agilent Infinity 1290 HPLC with a diode array detector set to 270 nm wavelength, was used for caffeine quantitation. Column temperature was set at 298 K for Chromolith High Resolution RP-18 encapped 150 - 4.6 mm. Mobile phase (methanol:water, 25:75) was set to 0.860 ml/min and 1.4 μ l as sample injection volume. Standards solutions were prepared at known concentrations in the range of 200 to 1000 mg/l. The calibration curve was correlated with $R^2=0.96690$.

Results and Discussion

Ilex guayusa L. leaves extract was identified by GC/MS in Figure 2. One sample of each extraction was analyzed. Caffeine, amyrin and squalene were identified as peaks at 30.5, 39.1 and 46.8 min, respectively. An important percentage of squalene was detected. The presence of amyrin is an interesting fact that could be studied further, and probably is the main reason for its estrogenic benefit properties [2].

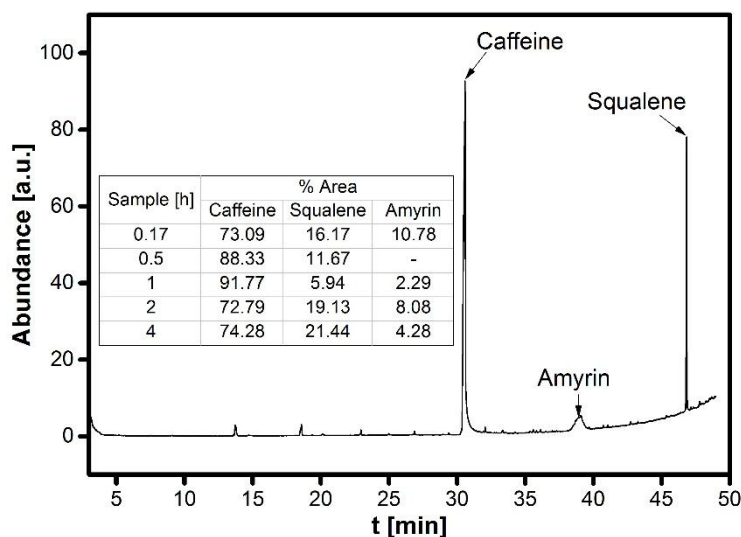

Figure 2. GC/MS analysis of *Ilex guayusa* L. SFE extract. Retention times: Caffeine, 30.5 min; amyrin, 39.1 min; squalene, 46.8 min. Relative areas are shown in table inset.

Experimental caffeine recovery percentage is given in Figure 3. At 2 h of dynamic extraction, 82 % of caffeine recovery was achieved. High amounts of solvent/GL ratio had to be used to reach good extraction yields (Table 1). For example, to reach 82 % of caffeine recovery, 309.4 (g SCCO₂ / g GL) was needed, but in same context, almost double amount of CO₂ had to be used for 7% recovery enhancement. This result was comparable to others obtained: Liang et.al. (2010) obtained 70.2% of caffeine from green tea leaves using 2.7% of ethanol as co-solvent at 353 K and 30 MPa during 2 h [39].

Additionally, Tello and Calvo (2011) obtained 84% of caffeine yield from coffee husks working at 373 K and 30 MPa during 5 h without co-solvent [23]. Also, Park et.al. (2007) achieved a maximum yield of extraction of 97.3% at 30 MPa, 343 K and 4.6% of ethanol as co-solvent during 2 h [40]. Considering those results, conditions tested here leads high caffeine recovery, varying from 48.5 to 89.7 (g caffeine / 100 g total caffeine) after 1 to 4 h. Further cost – benefit analysis is needed at the time of choosing the optimal time for extraction.

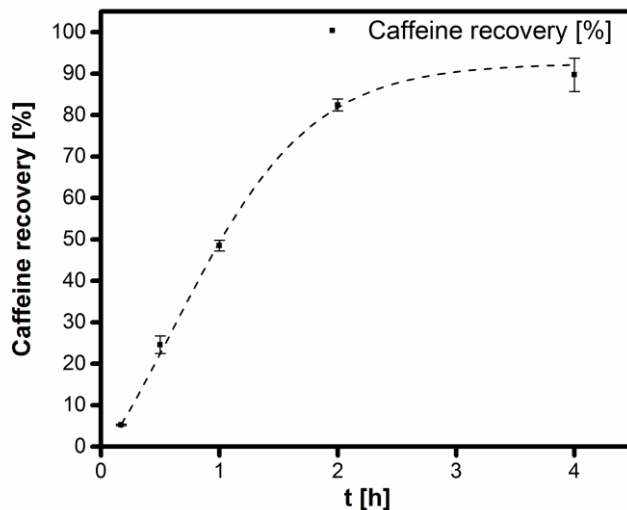

Figure 3. Caffeine recovery after SCCO₂ extraction from *Ilex guayusa* L. leaves as a function of extraction time, at P = 23 MPa, T = 328 K.

Table 1. Total caffeine extraction yield from *Ilex guayusa* L. leaves and selectivity of caffeine under different times of extraction.

Time (h)	Solvent mass ratio (g CO ₂ /g GL)	Co-solvent (g ethanol)	Yield (g caffeine/100g GL)	Recovery (g caffeine/100g initial caffeine)
0.17	119.4	13.2	0.21 ± 0.01	5.26
0.5	154.0	17.0	1.00 ± 0.09	24.60
1.0	205.8	22.7	1.97 ± 0.06	48.53
2.0	309.4	34.2	3.34 ± 0.06	82.45
4.0	516.6	57.0	3.64 ± 0.18	89.74

Considering g caffeine / 100 g GL, 3.64% was achieved after 4 hours of extraction. This result is better than the obtained by Gürü and İcen (2010), who reached a maximum caffeine to raw material yield of 1.495% for tea stalk and 1.892% for tea fiber [26]. However, those low values are justified because the raw materials used were tea plant wastes, probably with poor initial caffeine content. Moreover, Sökmen et.al. (2018) have found the best conditions for caffeine extraction from tea leaves at 25 MPa, 333 K and 3 hours, obtaining caffeine 1.80% yield [41]. Different operating conditions directly affect SFE extractable compounds yield, however having almost 90% of caffeine recovery is good enough for industrial applications.

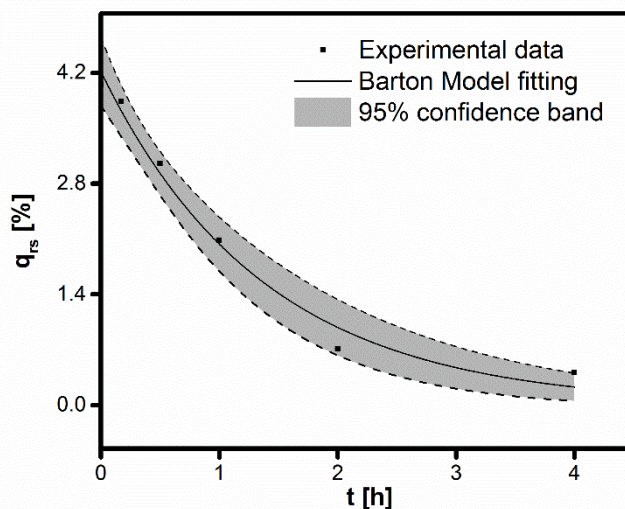

Figure 5. Experimental data fitted using Barton model. Confidence bands (95%) are shown in gray area.

Experimental data was fitted to Barton model (Figure 5). Data had a classic exponential decrease shape. Barton model fitting gives an intercept at $t=0$, giving $q_0 = 4.21\%$, which is similar to the obtained experimentally (4.05%). Although, parameters obtained by empirical models does not have physical interpretation, considering as an internal diffusion controlled extraction, the best fit was achieved with $k = 2.02E-4$, implying a calculated diffusion coefficient $D=1.34E-12\text{ m}^2/\text{s}$. Huang et.al. (2011) obtained solute diffusion coefficient in the range of $5.28E-9$ to $2.93E-8\text{ m}^2/\text{s}$, that are considerably higher than the determined here, suggesting that their operating conditions are more favorable to SFE [42]. However, Campos et.al. (2005) obtained diffusion coefficients more similar than presented here (in the range of $3.67E-12$ to $7.14E-12$) for *Callendula officinalis* oleoresin extraction, applying simple single plate model [43]. Results could vary depending on model, raw materials and operating parameters used, thus it is necessary to study mathematical modelling for each condition tested and test other models to compare results. Extraction predicted at 4 h is less than expected, but considering its standard deviation, it is well represented by the model with 95% confidence. It suggested that experimental errors could have been made in the data acquisition for that time.

Statistical analysis using AARD resulted on 13.8 % (Table 2). This result differs from Huang et.al. (2011), who compared Barton and Crank models in the CO₂ SFE of Baizhu, obtaining similar AARD values (from 2.4 to 8.7). Nevertheless, 95% confidence bands in model fittings show that data are reliable enough to be a starting point for future research.

Table 2. Model fitting parameters

Model	q_0 (%)	k (s ⁻¹)	D (m ² /s)	R ²	AARD (%)
Barton	4.05 ± 0.35	2.02E-4	1.34E-12	0.98279	13.8

q_0 : initial concentration of caffeine in *Ilex guayusa* L. leaves, k : kinetic constant for model fitting, D : diffusion coefficient, R²: correlation factor, AARD: average absolute relative deviation

Conclusions

The objective of this work has been to provide information about supercritical carbon dioxide caffeine extraction from *Ilex guayusa* L. leaves, to using it on future research or applications. Experimental conditions tested (23 MPa, 328 K, 3.5 g ethanol / 100 g SCCO₂) favors high caffeine recovery (89.74 g caffeine / 100 g total caffeine; 3.64 g caffeine / 100 g GL) after 4 hours of dynamic CO₂ SFE, considering as an important fact that only 7% of recovery enhancement was achieved from 2 to 4 hours of extraction. Although, kinetic modelling showed an average absolute relative deviation of 13.8 %, implying that Barton model was a preliminary model to fit the experimental data. Nonetheless, is recommended to analyze other mathematical models to enhance prediction accuracy.

Compared with similar works, results presented here are reliable enough to be considered as a starting point for future research. Finally, this work pioneered the analysis of supercritical CO₂ extraction of caffeine from *Ilex guayusa* L. leaves.

References

- [1] F. Yi, X. Zhao, Y. Peng, P. Xiao, Genus *Ilex* L.: Phytochemistry, Ethnopharmacology, and Pharmacology, Chinese Herb. Med. 8 (2016) 209–230. doi:10.1016/S1674-6384(16)60044-8.
- [2] F. Contero, S. Abdo, D. Vinueza, J. Moreno, M. Tuquinga, N. Paca, Estrogenic activity of ethanolic extracts from leaves of *Ilex guayusa* loes. and *Medicago sativa* in *Rattus norvegicus*, Pharmacologyonline. 2 (2015) 95–99.
- [3] H. Ashihara, A. Crozier, Caffeine: A well known but little mentioned compound in plant science, Trends Plant Sci. 6 (2001) 407–413. doi:10.1016/S1360-1385(01)02055-6.

- [4] B. Adnadjevic, B. Koturevic, J. Jovanovic, Comparative kinetic analysis of isothermal extraction of caffeine from guarana seed under conventional and microwave heating, *Chem. Eng. Res. Des.* 118 (2017) 61–70. doi:10.1016/j.cherd.2016.12.006.
- [5] A.A. Aynur Senol, Solid–liquid extraction of caffeine from tea waste using battery type extractor: Process optimization, *J. Food Eng.* 75 (2006) 565–573. doi:10.1016/J.JFOODENG.2005.04.039.
- [6] D.V. Bermejo, P. Luna, M.S. Manic, V. Najdanovic-Visak, G. Reglero, T. Fornari, Extraction of caffeine from natural matter using a bio-renewable agrochemical solvent, *Food Bioprod. Process.* 91 (2013) 303–309. doi:10.1016/j.fbp.2012.11.007.
- [7] M.T. Jafari, B. Rezaei, M. Javaheri, A new method based on electrospray ionisation ion mobility spectrometry (ESI-IMS) for simultaneous determination of caffeine and theophylline, *Food Chem.* 126 (2011) 1964–1970. doi:10.1016/j.foodchem.2010.12.054.
- [8] H. Sereshti, S. Samadi, A rapid and simple determination of caffeine in teas, coffees and eight beverages., *Food Chem.* 158 (2014) 8–13. doi:10.1016/j.foodchem.2014.02.095.
- [9] Q.-R. Li, M. Wu, R.-J. Huang, Y.-F. Chen, C.-J. Chen, H. Li, H. Ni, H.-H. Li, Extraction and preparation of high-aroma and low-caffeine instant green teas by the novel column chromatographic extraction method with gradient elution., *J. Food Sci. Technol.* 54 (2017) 2186–2192. doi:10.1007/s13197-017-2655-z.
- [10] H. XU, Y. ZHANG, C. HE, Ultrasonically Assisted Extraction of Isoflavones from Stem of *Pueraria lobata* (Willd.) Ohwi and Its Mathematical Model, *Chinese J. Chem. Eng.* 15 (2007) 861–867. doi:10.1016/S1004-9541(08)60015-4.
- [11] G.J. Swamy, K. Muthukumarappan, Optimization of continuous and intermittent microwave extraction of pectin from banana peels, *Food Chem.* 220 (2017) 108–114. doi:10.1016/j.foodchem.2016.09.197.
- [12] A.B.A. de Azevedo, P. Mazzafera, R.S. Mohamed, S.A.B. Vieira de Melo, T.G. Kieckbusch, Extraction of caffeine, chlorogenic acids and lipids from green coffee beans using supercritical carbon dioxide and co-solvents, *Brazilian Journal of Chemical Engineering* 25 (2008) 543-552.
- [13] R.S. Mohamed, M.D.A. Saldaña, P. Mazzafera, Extraction of caffeine, theobromine, and cocoa butter from Brazilian cocoa beans using supercritical CO₂ and ethane, *Industrial and Engineering Chemistry Research* 41 (2002) 6751-6758.
- [14] C.B. Mehr, R.N. Biswal, J.L. Collins, Supercritical carbon dioxide extraction of caffeine from Guaraná, *Journal of Supercritical Fluids* 9 (1996) 185-191.

- [15] M.D.A. Saldaña, R.S. Mohamed, P. Mazzafera, Supercritical carbon dioxide extraction of methylxanthines from Maté tea leaves, *Brazilian Journal of Chemical Engineering* 17 (2000) 251-260.
- [16] G.I. Burgos-Solórzano, J.F. Brennecke, M.A. Stadtherr, Solubility measurements and modeling of molecules of biological and pharmaceutical interest with supercritical CO₂, *Fluid Phase Equilibria* 220 (2004) 57-69.
- [17] Zosel, Process for the decaffeination of coffee, US Patent 4247570.
- [18] S. Peter, G. Brunner, Process for decaffeinating coffee, US Patent 4322445.
- [19] S.N. Katz, J.E. Spence, M.J. O'Brien, R.H. Skiff, G.J. Vogel, R. Prasad, Decaffeination of coffee, EU Patent 0424579B1.
- [20] O.G. Vitzthum, A.S. Clauis, N.A. El-Hag, V.N. Kapoor, Decaffeination of fermented unfired tea, EU Patent 0167399A2.
- [21] M.A. MacHugh, V.J. Krukoniš, *Supercritical Fluid Extraction. Principles and Practice*, 2nd ed., Butterworth-Heinemann series in chemical engineering. Stoneham, USA, 1994, pp. 1-16.
- [22] P.V. Gadkari, M. Balaraman, Solubility of caffeine from green tea in supercritical CO₂: a theoretical and empirical approach, *J. Food Sci. Technol.* 52 (2015) 8004–8013. doi:10.1007/s13197-015-1946-5.
- [23] J. Tello, M. Viguera, L. Calvo, Extraction of caffeine from Robusta coffee (*Coffea canephora* var. Robusta) husks using supercritical carbon dioxide, *J. Supercrit. Fluids.* 59 (2011) 53–60. doi:10.1016/j.supflu.2011.07.018.
- [24] G. Weber Brun, Á. Martín, E. Cassel, R.M.F. Vargas, M.J. Cocero, Crystallization of caffeine by supercritical antisolvent (SAS) process: Analysis of process parameters and control of polymorphism, *Cryst. Growth Des.* 12 (2012) 1943–1951. doi:10.1021/cg2016758.
- [25] J. Ke, C. Mao, M. Zhong, B. Han, H. Yan, Solubilities of salicylic acid in supercritical carbon dioxide with ethanol cosolvent, *J. Supercrit. Fluids.* 9 (1996) 82–87. doi:10.1016/S0896-8446(96)90002-9.
- [26] H. İcen, M. Gürü, Effect of ethanol content on supercritical carbon dioxide extraction of caffeine from tea stalk and fiber wastes, *J. Supercrit. Fluids.* 55 (2010) 156–160. doi:10.1016/j.supflu.2010.07.009.

- [27] D. Bermejo, E. Ibáñez, G. Reglero, T. Fornari, Effect of cosolvents (ethyl lactate, ethyl acetate and ethanol) on the supercritical CO₂ extraction of caffeine from green tea, *J of Supercritical Fluids*,(2015). doi:10.1016/j.supflu.2015.07.008
- [28] M.D. Gordillo, C. Pereyra, E.J. Martinez de la Ossa, Measurement and correlation of solubility of Disperse Blue 14 in supercritical carbon dioxide, *J. Supercrit. Fluids*. 27 (2003) 31–37. doi:10.1016/S0896-8446(02)00215-2.
- [29] Z. Huang, X. Shi, W. Jiang, Theoretical models for supercritical fluid extraction, *Journal of Chromatography A*, 1250 (2012) 2–26. doi.org/10.1016/j.chroma.2012.04.032
- [30] U. Kopcak, R.S. Mohamed, Caffeine solubility in supercritical carbon dioxide/co-solvent mixtures, *J. Supercrit. Fluids*. 34 (2005) 209–214. doi:10.1016/j.supflu.2004.11.016.
- [31] G.N. Sapkale, S.M. Patil, U.S. Surwase, P.K. Bhatbhave, *Supercritical Fluid Extraction*, *Int. J. Chem. Sci.* 8 (2010) 729–743.
- [32] U. Kopcak, R.S. Mohamed, Caffeine solubility in supercritical carbon dioxide/co-solvent mixtures, *J. Supercrit. Fluids*. 34 (2005) 209–214. doi:10.1016/j.supflu.2004.11.016.
- [33] P.P. Almeida, N. Mezzomo, S.R.S. Ferreira, Extraction of *Mentha spicata* L. Volatile Compounds: Evaluation of Process Parameters and Extract Composition, *Food Bioprocess Technol.* 5 (2012) 548–559. doi:10.1007/s11947-010-0356-y.
- [34] A. Barghamadi, M. Mehrdad, F. Sefidkon, Y. Yamini, M. Khajeh, Comparison of the volatiles of *achillea millefolium* L. Obtained by supercritical carbon dioxide extraction and hydrodistillation methods, *J. Essent. Oil Res.* 21 (2009) 259–263. doi:10.1080/10412905.2009.9700164.
- [35] A.S. Zarena, N.M. Sachindra, K. Udaya Sankar, Optimisation of ethanol modified supercritical carbon dioxide on the extract yield and antioxidant activity from *Garcinia mangostana* L., *Food Chem.* 130 (2012) 203–208. doi:10.1016/j.foodchem.2011.07.007.
- [36] L.D. Kagliwal, A.S. Pol, S.C. Patil, R.S. Singhal, V.B. Patravale, Antioxidant-Rich Extract from Dehydrated Seabuckthorn Berries by Supercritical Carbon Dioxide Extraction, *Food Bioprocess Technol.* 5 (2012) 2768–2776. doi:10.1007/s11947-011-0613-8.
- [37] Fields, Process for the production of an enriched natural antioxidant mixture from a single source plant, US Patent 9345707.
- [38] K. Nguyen, P. Barton, J.S. Spencer, Supercritical carbon dioxide extraction of vanilla, *J. Supercrit. Fluids*. 4 (1991) 40–46. doi:10.1016/0896-8446(91)90029-6.

- [39] Y. Liang, Q. Sun, S. Hua, J. Ye, J. Lu, X. Zheng, Decaffeination of green tea by supercritical carbon dioxide, 4 (2010) 1161–1168.
- [40] H.S. Park, H.-K. Choi, S.J. Lee, K.W. Park, S.-G. Choi, K.H. Kim, Effect of mass transfer on the removal of caffeine from green tea by supercritical carbon dioxide, *J. Supercrit. Fluids*. 42 (2007) 205–211. doi:10.1016/j.supflu.2007.03.002.
- [41] M. Sökmen, E. Demir, S.Y. Alomar, Optimization of sequential supercritical fluid extraction (SFE) of caffeine and catechins from green tea, *J. Supercrit. Fluids*. 133 (2018) 171–176. doi:10.1016/j.supflu.2017.09.027.
- [42] Z. Huang, M.-J. Yang, S.-F. Liu, Q. Ma, Supercritical carbon dioxide extraction of Baizhu: Experiments and modeling, *J. Supercrit. Fluids*. 58 (2011) 31–39. doi:10.1016/j.supflu.2011.05.008.
- [43] L.M.A.S. Campos, E.M.Z. Michielin, L. Danielski, S.R.S. Ferreira, Experimental data and modeling the supercritical fluid extraction of marigold (*Calendula officinalis*) oleoresin, *J. Supercrit. Fluids*. 34 (2005) 163–170. doi:10.1016/j.supflu.2004.11.010.