

# Analysis of Piezoelectric Sensors in Adulteration of Bovine Milk Using the Chromatic Technique <sup>†</sup>

Marcos Messias dos Santos Junior <sup>1,\*</sup>, José Alfredo Covolan Ulson <sup>1</sup>, Bruno Albuquerque de Castro <sup>1</sup>, Jorge Alfredo Ardila-Rey <sup>2</sup>, Fernando de Souza Campos <sup>1</sup> and Laura Teófilo Ferreira <sup>3</sup>

- 1 São Paulo State University (UNESP), School of Engineering, Bauru, Department of Electrical Engineering, 17033-360 Bauru-SP, Brazil; marcos.messias@unesp.br; alfredo.ulson@unesp.br; bruno.castro@unesp.br; fernando.casmpos@unesp.br.
- 2 Department of Electrical Engineering, Universidad Técnica Federico Santa María, Av. Vicuña Mackenna 3939, Santiago de Chile 8940000, Chile; E-Mail: jorge.ardila@usm.cl
- 3 Department of Chemistry, São Paulo State University, Av. Eng. Luiz Edmundo Carrijo Coube 14-01, Bauru, 17033-360, Brazil; laura.teofilo@unesp.br

\* Correspondence: marcos.messias@unesp.br; Tel.: +55-11-98538-1298

† Presented at the 5th International Electronic Conference on Sensors and Applications, 15–30 November 2018; Available online: <https://sciforum.net/conference/ecsa-5>.

**Abstract:** Sensors applied in the food industry are important tools to quality control. Current analyses checking adulteration in milk are expensive and time consuming, because the sample need to be evaluated in laboratory environment. Thus, is important to develop methodologies and sensors to monitoring milk production. A common type of fraud is performed adding substances such as sodium hydroxide in order to increasing milk shelf life. In this study, we propose to use low-cost piezoelectric diaphragms transducers to implement a methodology to identify milk adulteration by mechanical waves propagation method (vibration and acoustic emission). Two piezoelectric diaphragms were used, the first was excited by a chirp signal with 1 V of amplitude and a frequency band since 0 to 65 kHz with 2 Hz of step, and concomitantly was acquired the response signal of the second sensor installed in the opposite side since the actuator with a rate of 250 kHz. After acquire the data, these were processed using the chromatic technique, which extract three features: energy, average band and equivalent bandwidth, in order to classify the raw and the contaminated milk through clustering. The experimental results indicated that the methodology can differ raw and contaminated milk with 1% of sodium hydroxide. Therefore, the results reported in this study indicate that low-cost piezoelectric diaphragms are promissory to liquids quality control.

**Keywords:** Piezoelectric diaphragms; low-cost; bovine milk adulteration; chromatic technique

---

## 1. Introduction

The development of quality control tools applied to food industry is an essential to prevent some issues such as food adulteration. Adulterated food is dangerous for health once it may contain several toxic substances, which can deprive the normal development of human body or even lead to serious disorders and sickness [1-3]. Therefore, nowadays, both science and industry have sought to develop sensors and devices aiming to promote the correct quality control of food diagnosis condition, in order to promote human healthy and consumption safety. One of the most food which is commonly adulterated is a milk. A common type of fraud is accomplished in order to increasing milk shelf life adding substances such as water, sodium hydroxide ( $NaOH$ ), peroxide hydrogen ( $H_2O_2$ ), etc [1-3]. As an example, the effects of sodium hydroxide on human health can be a stomach-burning sensation, nausea and vomit [2].

Most of milk adulteration measurements are expensive and time consuming, as the milk samples need to be taken to the dairy laboratories for testing. Therefore, currently, the development of low

cost, rapid and reliable sensors and systems which aims to detect milk adulteration is an essential to guarantee the quality level of human healthy safety and the quality of industrial production [3]. In order to contribute in this issue, in this study, we propose to implement a methodology to identify milk adulteration by acoustic emission propagation method using low-cost piezoelectric diaphragms. Acoustic waves will be propagated in the milk and the acoustic signals will be processed by the chromatic signal processing technique (CT) [4]. This promising digital signal processing can be used to achieve a patten recognizing or cluster data and it will be applied to separate samples of pure and contaminated milk. As it an initial study, we use sodium hydroxide 1 %, as a chemical adulteration in a sample of pure milk. This type of contamination is commonly accomplished on industry, according to [2]. The results indicated that the proposed method has great applicability in the identification of milk adulteration.

The outline of this article is as follows: subsection 1.1 presents the basics concepts of acoustic emission by piezoelectric transducers. Section 1.3 presents the concepts of chromatic cluster technique and the experimental setup is described in Section 2. In Section 3 the results are discussed and the conclusion of this paper is presented in section 4.

### 1.1. Piezoelectric Sensors and Acoustic Emission (AE)

The piezoelectric transducers can operate both as sensors and actuators due the piezoelectric effect [5-8]. The piezoelectric effect occurs in materials that, when subjected to a mechanical stress, produce an output voltage by the direct effect. The reverse effect also occurs: by applying an electric voltage in the piezoelectric, a mechanical deformation is produced [5-8]. Due the piezoelectric effect, the transducer can be configured as an actuator, and vibration or ultrasound waves can be emitted by applying a voltage in a determined frequency range. Besides that, it also can be configured as a sensor, since the piezoelectric is sensitivity to vibration and acoustic waves.

Fig. 1 presented the transducer applied in this work, which is commonly applied in structure monitoring [7, 9] and in partial discharge diagnosis [6]. This type has a ceramic disk of 25.0 mm × 0.23 mm and a brass plate of 35.0 mm × 0.30 mm [10].

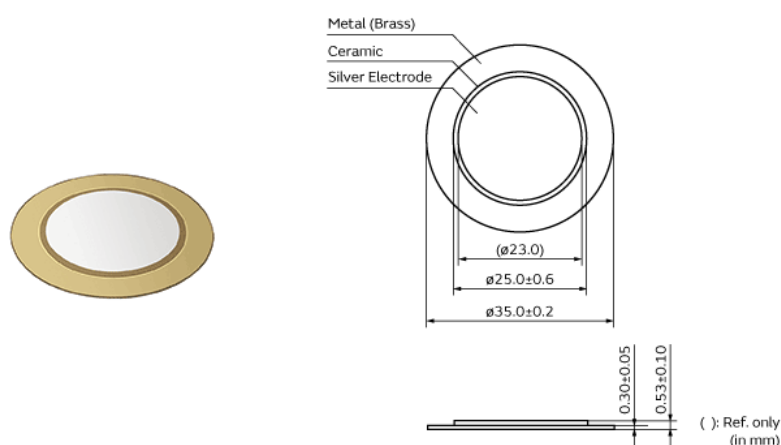

**Figure 1.** Murata piezoelectric sensor 7BB-35-3 used in the experiment [10].

Acoustic wave propagation can change according to the fluid properties [11]. In this work we use two piezoelectric transducers, one operating as the actuator and the other operating as a receiver sensor (pitch-catch mode) [12]. The emitter had the function of generate the mechanical waves in a sample of milk and the adulteration detection will be accomplished by processing the acoustic signals captured by the receptor, since the AE propagation can change with the material alters or fluid contamination. As explained in the follow section and in the experimental setup, the chromatic technique is used to differentiate the raw and contaminated milk by 1 % of NaOH.

### 1.2. Chromatic Technique (CT)

The chromatic technique is a signal processing approach which aims to provide a series of parameters that facilitate the extraction of information from a complex group of signals whose characteristics cannot be easily identified [13-15]. It has been demonstrated that this technique also enables, for some types of applications, the identification the correlation of the parameters that define the signals, determining if a group of signals can be identifiable from a chromatic point of view [9][10][11]. According to this technique, the signal  $f(t)$  classification is carried out by means of three signal principal parameters: energy ( $E$ ), average band ( $\omega_c$ ) and equivalent bandwidth ( $B_{Av}$ ), as follows:

$$E = \frac{1}{2\pi} \sum_{i=0}^k F_i, \tag{3}$$

$$\omega_c = \frac{\sum_{i=1}^k \omega_i F_i^2}{2\pi E_b}, \tag{4}$$

$$B = \sqrt{\frac{1}{E_b} \sum_{i=0}^k (\omega_i - \omega_c)^2 F_i^2}, \tag{5}$$

where  $F_i$  and  $\omega_i$  is the Fourier transform and the angular frequency of a signal  $f[n]$  in discrete time.

In this work, the CT was accomplished in order to cluster 200 samples of milk, in which 100 is regarded a raw milk and another 100 samples was an adulterated milk.

## 2. Experimental Setup

As the objective is to perform a milk adulteration detection, the sensor device was built by applying two piezoelectric on each end of a test tube, according to the Figure (1).

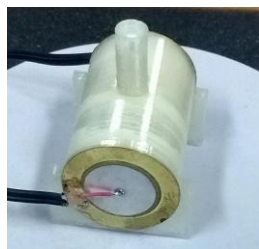

(a)

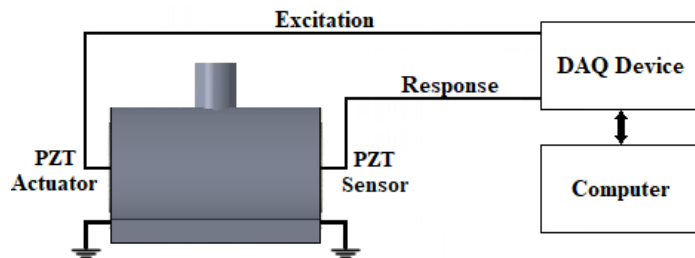

(b)

**Figure 2.** Experimental Setup (a) and sensor device (b).

The setup was performed using a NI USB-6211 data acquisition (DAQ) device with a sampling rate of 250 kHz. The actuator was excited by a signal chirp whose amplitude was 1 V and whose frequency range was from 0 kHz to 65 kHz with a step of 2 Hz. The signal of the receptor, installed in the opposite side of the actuator, was acquired with a sample rate of 250 kHz.

The receptor signal was processed by chromatic technique. Two hundred samples of milk, which one hundred were adulterated with NaOH and the others one hundred samples were a raw milk, was inserted in a test tube. This setup produced 200 signals that were processed by the CT. The results are presented in the next section.

## 3. Results and Discussion

The Figure 3 shows the results obtained by applying the chromatic signal processing technique. It was used as clustering and separation approach in order to promote the correct milk diagnosis condition.

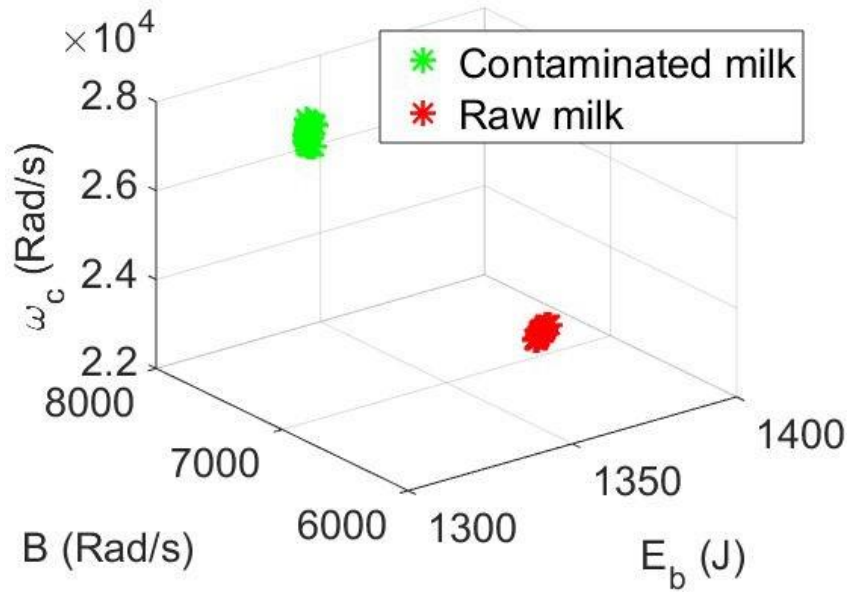

Figure 3. 3D classification map of the chromatic technique.

As observed in the result presented, the CT performed a correct feature extraction for milk condition, once the color maps formed by the 100 data points of raw milk is totally separated of the 100 data points of contaminated milk condition. Table 1 presented the average of each CT parameter for raw and adulterated milk.

Table 1. Average of CT parameters.

Feature	Raw Milk	Adulterated Milk
Energy $E_b$ (J)	1337	1365
Average band B (Rad/s)	7746	6661
Equivalent bandwidth $\omega_c$ (Rad/s)	26862	23262

As observed, the average energy was 2 % higher for adulterated milk in relation to the raw condition. However, the average band and equivalent bandwidth decreases, respectively 14 % and 13.4 % for adulterated milk in relation to the pure.

In order to study the relevance of each parameter to cluster the milk condition and perform the correct diagnosis of adulteration, the Figure 4 a, b and c presented the 2D maps of the chromatic parameters.

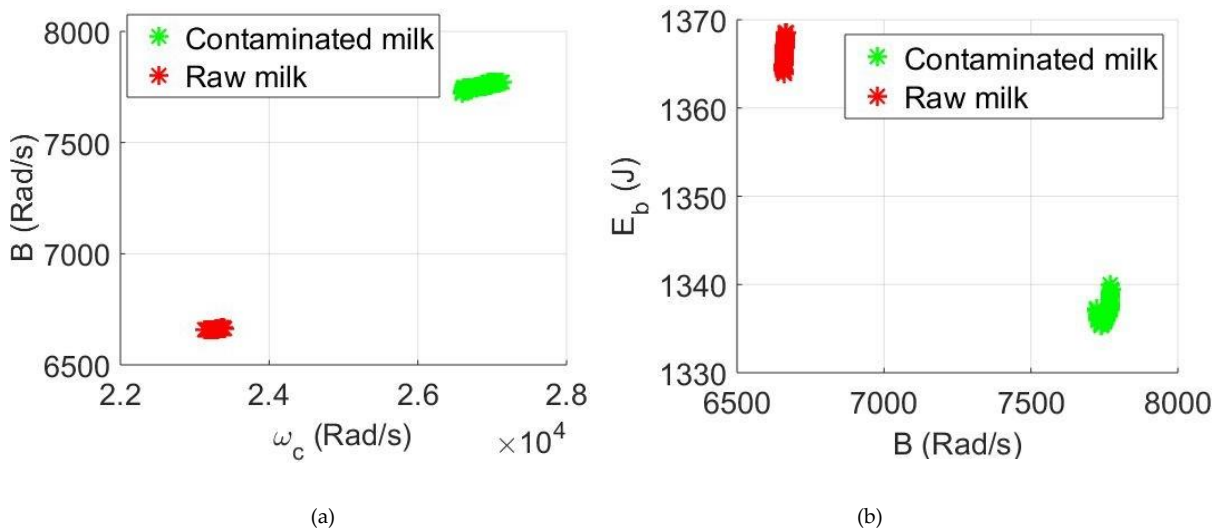

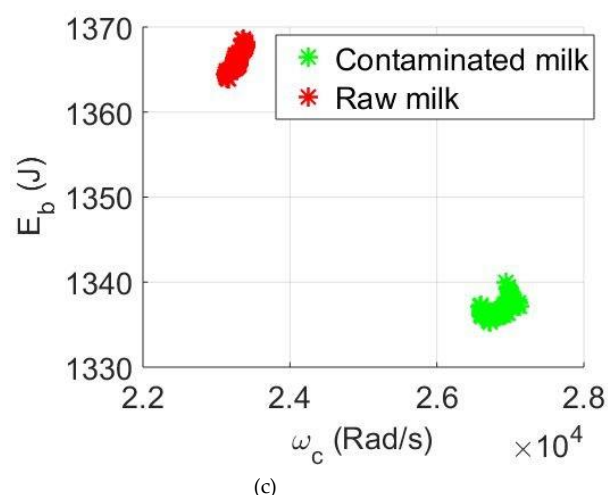

Figure 4. 2D Representation map. (a)  $E_b$  -  $B$ , (b)  $E_b$  -  $\omega_c$  and (c)  $B$  -  $\omega_c$

Regarding these results, it can be concluded that all parameters have a significant relevance, since all 2D maps achieved the cluster data of a milk condition. Therefore, it can be concluded that also 2D maps can be an alternative to detect milk adulteration in these experimental setup condition.

#### 4. Conclusions

Sensors applied in the milk quality control is an important tool to ensure a better quality for the consumers. In this study, a pair of low-cost piezoelectric diaphragm was used in order to contribute in the direction of a methodology cheaper and faster evaluation of milk quality diagnosis. The chromatic technique application was able to differentiate the raw milk from the milk with 1% of sodium hydroxide using the data of the characteristics of mechanical acoustic propagation in the different samples, which were generated and acquired by the pair of emitter and receiver of piezoelectric diaphragms. Therefore, the results reported in this study indicate that low-cost piezoelectric diaphragms are promissory to liquids quality control. From this work, some possibilities of future researches appear, such as:

- Verify whether the method identifies different variations in the concentration of contamination;
- To investigate if the sensor can differentiate more common milk contamination such as deionized water, hydrogen peroxide and formaldehyde;
- Apply the methodology to identify adulteration in other liquids such as gasoline, diesel and alcohol.

**Author Contributions:** all authors contributed in writing, proofreading, and providing suggestions for the improvement of the paper.

**Conflicts of Interest:** The authors declare no conflict of interest.

#### References

1. Ali Afzal, M. S. Mahmood, Iftikhar Hussain and Masood Akhtar, T. Adulteration and Microbiological Quality of Milk (A Review). *Pakistan Journal of Nutrition*, **2011**, 1196, 184-203.
2. Durante, G.; Becari, W.; et al. "Electrical Impedance Sensor for Real-Time Detection of Bovine Milk Adulteration." *IEEE Sens. J.*, **2016**, 1, 1.
3. M.F. Mabrook and M.C. Petty, T. A novel technique for the detection of added water to full fat milk using single frequency admittance measurements. *Science Direct Sensors and Actuators*, **2016**, 1, 1.

4. X. Wang; X. Li; M. Rong; et al. "UHF signal processing and pattern recognition of partial discharge in gas-insulated switchgear using chromatic methodology". *Sensors*, 2017, 17, 177. <http://dx.doi.org/10.3390/s17010177>
5. Castro, B.A.; Brunini, D. M.; Baptista, F.G.; et al. Assessment of macro fiber composite sensors for measurement of acoustic partial discharge signals in power transformers. *IEEE Sens. J.* **2017**, *17*, 6090–6099.
6. Castro, B.A.; Clerice, G. A. M.; Andreoli, A.L.; et. al. A low cost system for acoustic monitoring of partial discharge in power transformer by Piezoelectric Sensor. *IEEE Lat. Am. Trans.* **2016**, *7*, 3225-3231.
7. Freitas, E.S.; Baptista, F.G.; Budoya, et al. Equivalent circuit of piezoelectric diaphragms for impedance-based structural health monitoring applications. *IEEE Sensors J.* **2017**, *17*, 5537-5546.
8. Meitzler, A.H. et al. IEEE Standard on Piezoelectricity: An American National Standard. New York: IEEE-ANSI, 66 p., (Std, 176),**1988**
9. Budoya, D.; Castro, B.D.; Campeiro, L.; et al. Analysis of Piezoelectric Diaphragms in Impedance-Based Damage Detection in Large Structures. *Proceedings* **2018**, *2*, 131.
10. Available online: <https://www.murata.com/en-us/products/sound/diaphragm> (accessed on Oct 11, 2018).
11. Singh, V. R.; Dwivedi, S. "Ultrasonic Detection of Adulteration in Fluid Foods" Proceedings RC IEEE-EMBS. **1995**, 1.
12. Castro, B. A.; Baptista, F. G.; Ciampa, F. "Impedance-based Structural Health Monitoring Under Low Signal-to-Noise Ratio Conditions", Proceedings of 9th European Workshop on Structural Health Monitoring, pp. 1-12, **2018**.
13. G. R. Jones; P. C. Russel; A. Vourdas; et al. "The Gabor transform basis of chromatic monitoring". *Meas. Sci. Technol.*, **2000**, *11*, 489–498. <http://dx.doi.org/10.1088/0957-0233/11/5/307>
14. Ardila-Rey, J. A.; Montaña, J; Castro, B. A.; et al. "A Comparison of Inductive Sensors in the Characterization of Partial Discharges and Electrical Noise Using the Chromatic Technique" *Sensors*, **2018**, *18*, 1021. <https://doi.org/10.3390/s18041021>
15. R. S. Cheng and S. Verdu "Capacity of root-mean-square bandlimited Gaussian multiuser channels". *IEEE Trans. Inf. Theory.* **1991**, *37*, 453-465. <http://dx.doi.org/10.1109/18.79901>



© 2018 by the authors. Submitted for possible open access publication under the terms and conditions of the Creative Commons Attribution (CC BY) license (<http://creativecommons.org/licenses/by/4.0/>).