



Harvester of energy on PZT thin films †

Victor Petrov

Southern Federal University, Research and Education and Centre “Microsystem technics and multisensor monitoring systems”, 2, Chekhov St., Taganrog, 347922, Russia; e-mail: vvpetrov@sfedu.ru

* Correspondence e-mail: vvpetrov@sfedu.ru; Tel.: 8(8634) 37-16-24

† Presented at the 5th International Electronic Conference on Sensors and Applications, 15–30 November 2018; Available online: <https://sciforum.net/conference/ecsa-5>.

Received: date; Accepted: date; Published: date

Abstract: The design was developed and investigated, and a laboratory sample of energy harvester based on 1–1.5 μm thick PZT films was assembled. PZT films were formed on oxidized silicon by high-frequency reactive plasma sputtering in the oxygen atmosphere. The laboratory sample of the energy harvester was sensitive to mechanical acceleration and vibration. Testing of sensors on a special electrodynamic stand showed that the sensor has a high sensitivity in the frequency range from 2 to 5 Hz with a sensitivity of up to 75 pC/g, which corresponds to sensitivity of 1.2–1.5 V/g. The same design of the energy harvester was sensitive to scattered electromagnetic energy with a sensitivity of $6.8 \cdot 10^{-4}$ V/(V/cm). The maximum response to the electromagnetic field was observed at a frequency of 100–200 Hz.

Keywords: ferroelectric materials, semiconductor materials, composite materials, energy converters, gas sensors, physical sensors

1. Introduction

Recently, much attention has been paid to the development of instruments for collecting and converting energy dispersed by the environment – energy harvesters [1–4]. The main materials used to convert mechanical energy (energy of motion, vibrations) into electrical energy are piezo- and ferroelectric materials. The most popular material that has a significant piezoelectric effect is lead zirconate titanate $\text{Pb}(\text{Zr}, \text{Ti})\text{O}_3$ (PZT), which is widely used in electromechanical sensors, actuators and electrostatic energy generators [5]. Due to their high piezoelectric properties [6], PZT films are used in energy harvesters [7]. PZT films are formed by the method of high-frequency reactive plasma sputtering [8], a sol-gel method [9] of pulsed laser deposition [10].

The most common design of piezoelectric energy harvesters is a balk construction fixed on one side [6, 9, 11]. This design is widely used in microelectromechanical structures (MEMS). Silicon or metal is used as the balk material. The active material is a ferroelectric film. The small size of this design allows to reduce the resonant frequency and expand the range of mechanical deformations, thus increasing the conversion efficiency [12].

2. Materials and Methods

One of the main materials for piezoelectric energy harvesters is lead zirconate titanate $\text{Pb}(\text{Zr}_x\text{Ti}_{1-x})\text{O}_3$, which has high piezoelectric properties when $x = 0.48 \dots 0.5$.

We have developed a laboratory sample of energy harvester based on thin PZT films with a thickness of 1.0–1.5 μm – Figure 1 [8, 13, 14]. PZT films were formed by high-frequency reactive plasma sputtering in the oxygen atmosphere. Films were formed on top of a thin layer of silicon dioxide.

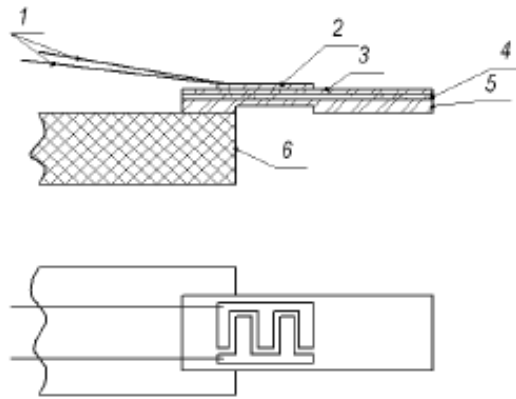

Figure 1. Schematic of laboratory sample of energy harvester : 1 - wires; 2 - contact pads; 3 - PZT film; 4 - silicon oxide; 5 - silicon.

Metallic (Cu-Ni-V) contacts were formed over the PZT film. The size of laboratory sample was $20 \times 10 \times 0.3 \text{ mm}^3$. One end of the sample was secured by mechanical clamping. Two wires were soldered to metal contacts.

For research the effect of vibration, the laboratory sample was placed in a metal housing. In the housing there were mounted connectors for connecting the energy harvester to the charge sensitive amplifier ПИИ2731Е (Russia) and the Tektronix TBS1042 (China) oscilloscope. The input impedance of the amplifier was not worse than 10^{10} Ohm , and the amplification factor was equal to 1 mV/pC .

The energy harvester was tested for vibration by a calibrated load on the BCB-206 (Russia) electrodynamic test bench. The energy harvester was tested for the effects of accelerations from 0.08 to 5g in the frequency range from 2 to 90 Hz [14].

For research the effect of an alternating electric field, a laboratory sample was placed between two metallic electrodes. The dimensions of the electrodes were slightly larger than the sample size. An alternating electric field was generated between the electrodes with a frequency from 20 Hz to 100 kHz and electric intensity varied in the range of 1-100 V/cm. Measurements were performed using the above amplifier and oscilloscope.

3. Results

The resulting sample was sensitive to mechanical acceleration and vibration. Tests of the sensor with a calibrated load were carried out on a special electrodynamic stand. It was demonstrated that the laboratory sample of energy harvester exhibits a power dependence of sensitivity on the acceleration frequency. The highest sensitivity is manifested in the frequency range from 2 to 5 Hz with a sensitivity of up to 75 pC / g - Figure 2, a.

The same sensor design turned out to be sensitive to scattered electromagnetic energy. Measurements in the range of 1-100 V/cm showed that sensitivity to field strength was $6.8 \cdot 10^{-4} \text{ V/(V/cm)}$. The maximum sensitivity was achieved at frequencies of the electromagnetic field of 100-200 Hz – figure 2, b.

The higher sensitivity of the energy harvester to the electromagnetic field with a frequency of 100–200 Hz can be explained by the fact that there are domains in the structure of PZT that can change their orientation at the specified frequency. With a higher frequency of the electromagnetic field, they no longer had time to react to its change.

It is known that the intensity of scattered electromagnetic field in the atmosphere can reach hundreds of V/m. In the case of using thousand of such energy harvesters, you can get an output signal up to 1 V.

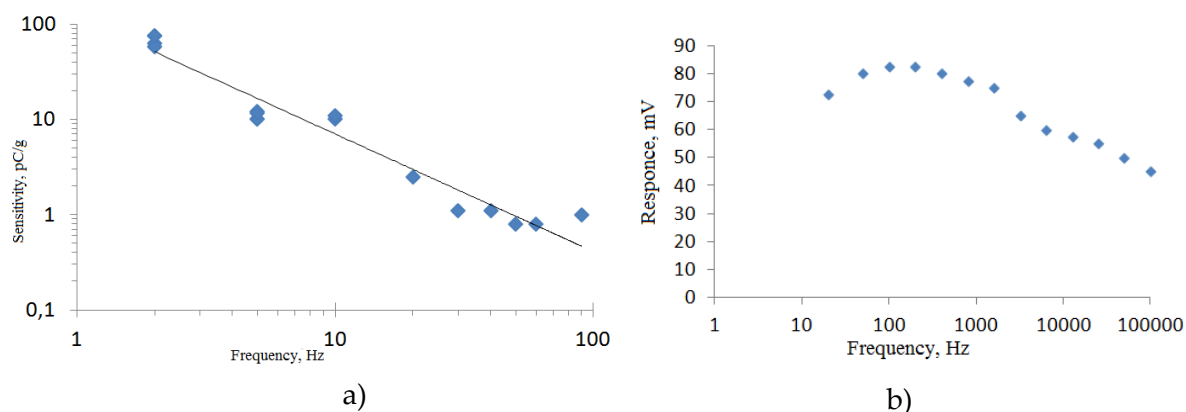

Figure 2. Dependence of energy harvester sensitivity on mechanical oscillations (a) and its response on the frequency of the electric field (b).

Thus, on the basis of small-sized structures based on PZT films, it is possible to obtain autonomous energy sources.

Funding: The reported study was funded by RFBR according to the research project № 18-29-11019.

Conflicts of Interest: The funders had no role in the design of the study; in the collection, analyses, or interpretation of data; in the writing of the manuscript, or in the decision to publish the results.

References

1. Radousky, H.B., Liang, H. Energy harvesting: an integrated view of materials, devices and applications *Nanotechnology* **2012**, *23*, 502001 (35pp) DOI:10.1088/0957-4484/23/50/502001.
2. Khan, A., Abas, Z., Kim, H.S., Oh, I.-K. Piezoelectric thin films: an integrated review of transducers and energy harvesting *Smart Materials and Structures* **2016**, *25*, 053002 (16pp) DOI:10.1088/0964-1726/25/5/053002.
3. Bowen, C.R., Kim, H.A., Weaver, P.M., Dunn, S. Piezoelectric and ferroelectric materials and structures for energy harvesting applications *Energy & Environmental Science* **2014**, *7*, P.25–44. DOI: 10.1039/c3ee42454e.
4. Li, H., Tian, C., Deng, Z.D. Energy harvesting from low frequency applications using piezoelectric materials *Applied Physics Reviews* **2014**, *1*, 041301 (20pp). DOI:10.1063/1.4900845.
5. Izyumskaya, N., Alivov, Y.-I., Cho, S.-J., Morkocet, H. Processing, Structure, Properties, and Applications of PZT Thin Films *Critical Reviews in Solid State and Materials Sciences*, **2007**, *32*, pp.111–202. DOI:10.1080/10408430701707347
6. Kim, M., Hwang, B., Jeong, J., Min, N.K., Kwon, K.H. Micromachining of a bimorph Pb(Zr,Ti)O₃ (PZT) cantilever using a micro-electromechanical systems (MEMS) process for energy harvesting application *J. Nanosci. Nanotechnol.* **2012**, *12*, *7*, pp.6011–6015. DOI: [10.1166/jnn.2012.6365](https://doi.org/10.1166/jnn.2012.6365).
7. Kang, M.-G., Jung, W.-S., Kang, Ch.-Y., Yoon, S.-J.. Recent Progress on PZT Based Piezoelectric Energy Harvesting Technologies *Actuators* **2016**, *5*, *5* (17pp). DOI:10.3390/act5010005.
8. Kovalenko, D.A., Petrov, V.V. Researches of the Internal Mechanical Stresses Arising in Si-SiO₂-PZT Structures //Journal of nano- and electronic physics. 2015. Vol.7. № 3. P. 03036(5pp).
9. Xiong, S., Kawada, H., Yamanaka, H., Matsushima, T. Piezoelectric properties of PZT films prepared by the sol-gel method and their application in MEMS *Thin Solid Films* **2008**, *516*, p.5309–5312. DOI:10.1016/j.tsf.2007.07.085.
10. Gatabi J.R., Rahmana, S., Amaro, A., Nash, T., Rojas-Ramirez, J., Pandey, R.K., Droopad, R. Tuning electrical properties of PZT film deposited by Pulsed Laser Deposition *Ceramics International*. **2017**, *43*, *8*, P. 6008-6012. DOI:10.1016/j.ceramint.2017.01.139
11. Kim, M., Hwang, B., Min, N.K., Jeong, J., Kwon, K.H., Park, K.B. Design and fabrication of a PZT cantilever for low frequency vibration energy harvesting *J. Nanosci. Nanotechnol.* **2011**, *11*, 6510–6513. DOI:10.1166/jnn.2011.4324

12. Liu, H.C., Tay, C.J., Quan, C.G., Kobayashi, T., Lee, C. Piezoelectric MEMS energy harvester for low-frequency vibrations with wideband operation range and steadily increased output power *J. Microelectromech. Syst.* **2011**, *20*, pp.1131–1142. DOI:10.1109/JMEMS.2011.216248
13. Kovalenko, D.A., Petrov, V.V., Klindukhov, V.G. Research of influence of technological parameters of formation of thin films of zirconate-titanate of lead on their structural and electrophysical properties *Izvestiya SFedU. Engineering Sciences* **2014**, *9*, p.124-132.
14. Petrov, V.V., Kemencev, A.S., Cherepakhin, I.I., Kovalenko, D.A. Investigation of the characteristics of a vibration sensor based on ferroelectric films of lead zirconate titanate *Izvestiya SFedU. Engineering Sciences*, **2016**, *10*, p.12-19.



© 2018 by the authors. Submitted for possible open access publication under the terms and conditions of the Creative Commons Attribution (CC BY) license (<http://creativecommons.org/licenses/by/4.0/>).