

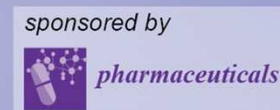

5th International Electronic Conference on Medicinal Chemistry

1-30 November 2019

chaired by Dr. Jean Jacques Vanden Eynde



The 3'UTR of the West Nile Virus genomic RNA is a potential antiviral target site

Sara Ramos-Lorente, Isabel Pérez-Jover, Cristina Romero-López* and Alfredo Berzal-Herranz*

¹ Instituto de Parasitología y Biomedicina “López-Neyra”, IPBLN-CSIC
PTS Granada. Av del Conocimiento 17, 18016 Granada, Spain

* Corresponding author: cristina_romero@ipb.csic.es; aberzalh@ipb.csic.es



The 3'UTR of the West Nile Virus genomic RNA is a potential antiviral target site

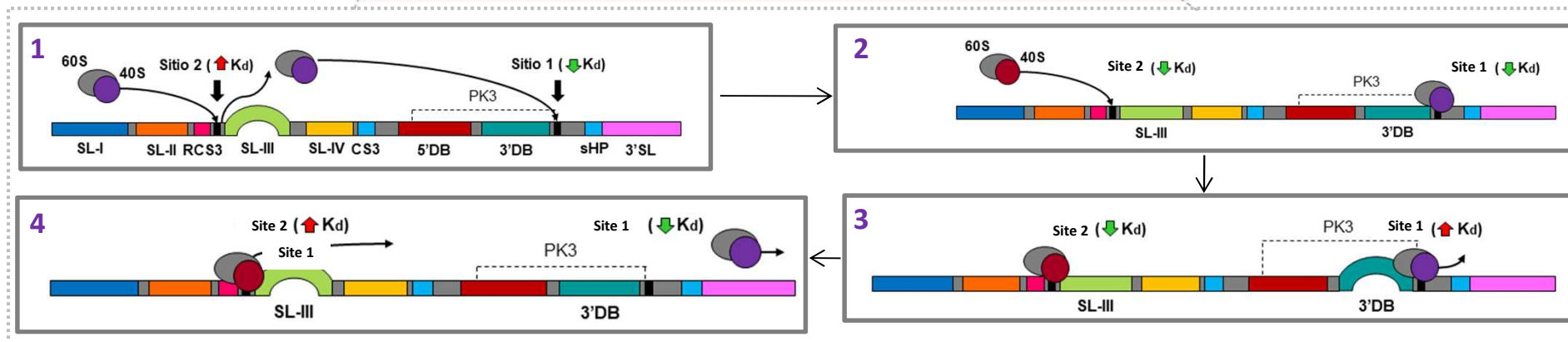
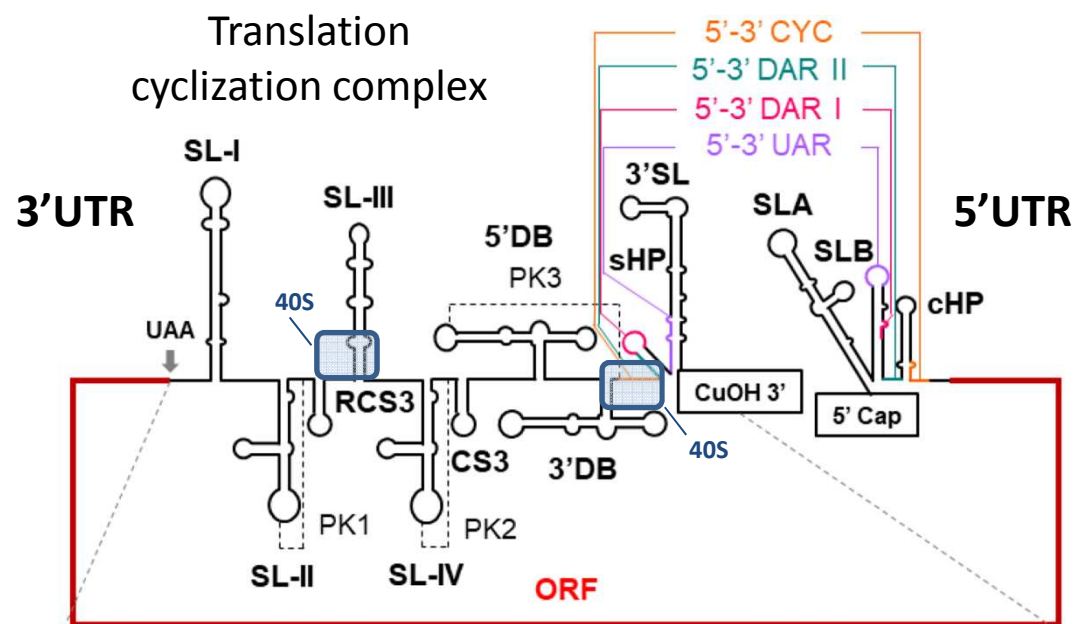

5th International Electronic Conference
on Medicinal Chemistry
1-30 November 2019

sponsors:   pharmaceuticals

Abstract:

The protein coding-information only represents a small portion of the genetic load of a living organism. It is well established that essential information codes functional RNAs, called non-coding RNAs (ncRNAs), which play key roles in the essential biological processes of the cell life. Many mRNAs also act as truly ncRNAs besides being translated into proteins. Therefore, the repertoire of potential drug targets to fight diseases goes beyond proteins. Viral RNA genomes encode all the information for completion of the infectious cycle. They are multifunctional molecules, which act as replication templates and mRNAs. Further, defined structural domains in viral RNA genomes play key functions for the completion of the viral cycle and the regulation of the essential processes; these domains have also been involved in virulence. The West Nile Virus (WNV) genome consists in a single stranded RNA molecule, which contains a single ORF flanked by untranslated regions (UTRs). The 3'UTR is required for efficient translation, but the mechanisms involved in this regulation are still obscure. In this work, we show evidences that the WNV-3'UTR specifically recruits the 40S ribosomal subunit. We have localized two potential binding sites of the 40S. Binding of the 40S induced conformational changes in highly conserved structural domains within the WNV-3'UTR. Functional assays support the hypothesis that recruitment of the 40S particle by the 3'UTR is required for an efficient translation. Interfering with the 40S recruitment, by targeting the WNV-3'UTR binding sites, constitutes a potential antiviral strategy by the development of new therapeutic compounds.

Keywords: Genomic RNA; ncRNAs; WNV; antiviral; RNA as target



5th International Electronic Conference
on Medicinal Chemistry
1-30 November 2019

sponsors:   pharmaceuticals

Introduction: West Nile Virus: General features

- ⇒ West Nile Virus (WNV) takes the name from the West Nile district of Uganda, place of residence of the woman from whose blood it was first isolated in 1937.
- ⇒ It is an enveloped single-stranded, positive-sense RNA virus belonging to the genus *Flavivirus* (family *Flaviviridae*).
- ⇒ The genus *Flavivirus* includes a number of viruses responsible for important outbreaks of human diseases around the world, such as West Nile, Dengue, Zika, Yellow Fever, Japanese Encephalitis, among others

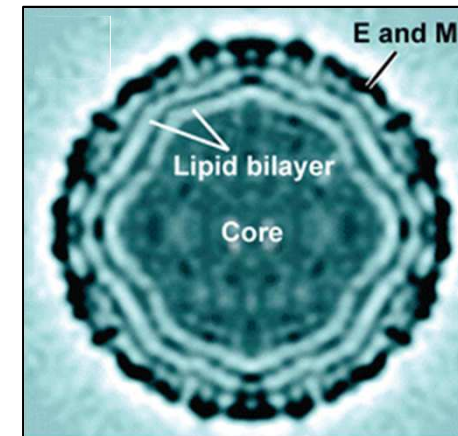

Figure reproduced from Mukhopadhyay *et al.*, 2003, *Science*, 302 (5643):248



5th International Electronic Conference
on Medicinal Chemistry
1-30 November 2019

sponsors:   pharmaceuticals

Introduction: West Nile Virus

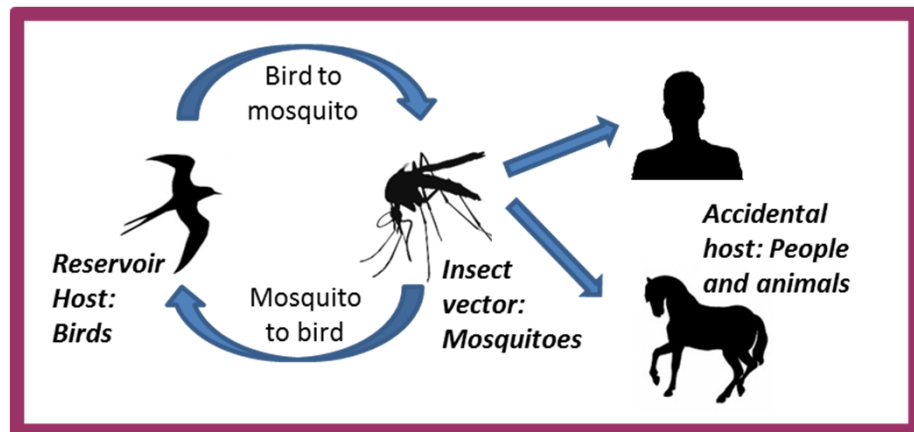

Transmission cycle: WNV mainly infects birds, but it can be transmitted by the bite of infected mosquitoes (genus *Culex*) to humans and horses, in which it causes outbreaks of severe encephalitis and febrile disease.

Epidemiology: WNV is considered the most widespread arbovirus in the world. It is endemic of Africa, Middle East and East Europe. During the 1990s, the virus spread from Asia, Africa and Australia to Europe and America. Since the 1999 outbreak in New York, it was declared as a world health threat by the WHO. The lack of efficient vaccines and drugs to fight the infection aggravates its consequences. Therefore, it is necessary to continue pursuing the development of therapeutic strategies.



Introduction: The West Nile Virus genome

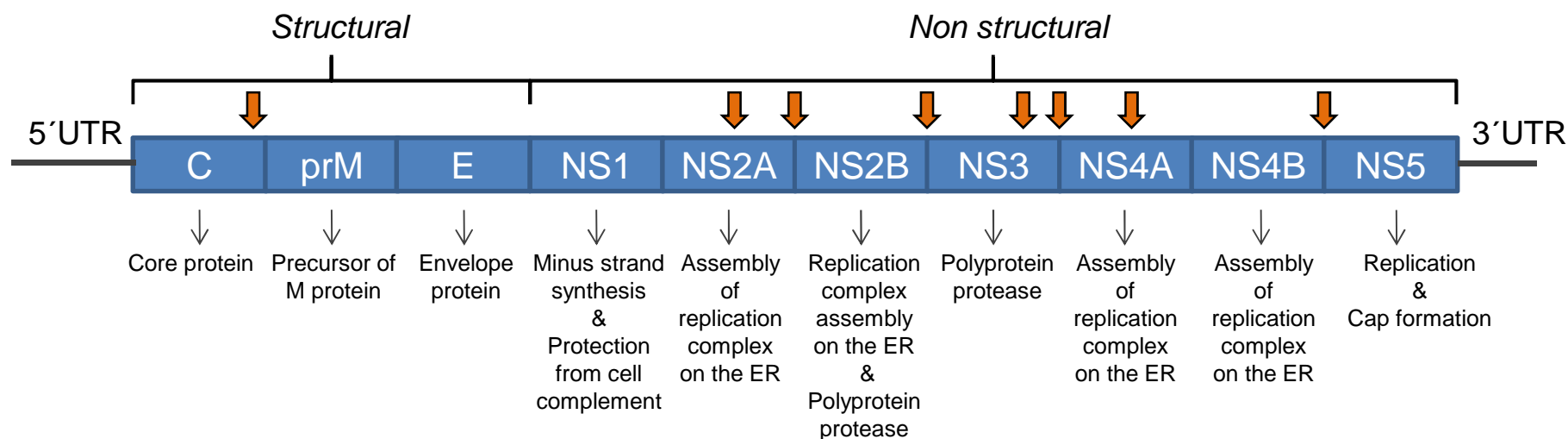

The genome consists on a single-stranded positive-sense RNA molecule approximately 11,000 nt long, with a cap structure at its 5' end. It lacks poly A tail at the 3' end. It contains a single open reading frame (ORF) that codes a polyprotein, which is processed to yield all viral structural and non structural proteins.



Introduction: The West Nile Virus genome information coded within the structural RNA elements

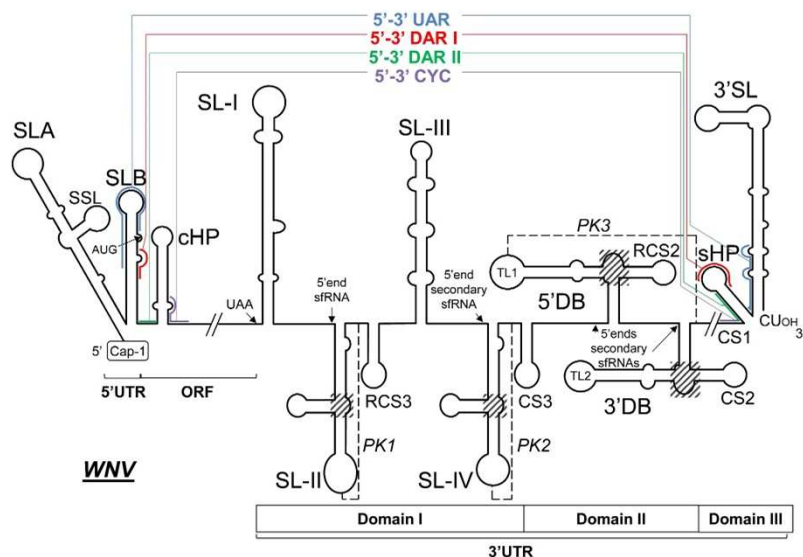

The ORF is flanked by the 5' and 3' untranslated regions (UTRs), which are defined by discrete highly conserved structural RNA elements with important roles in the viral cycle.

→ Viral RNA genomes are compact entities that use a storing information system beyond the protein-coding one to carry all the required information for the completion of the infective cycle.

→ This is achieved by the acquisition of discrete structural units that play key defined functions. This RNA units are distributed throughout the genome.

→ The mechanism by which RNA units exert their functions via the establishment of long distant RNA-RNA interactions and by the recruitment of cellular and viral factors.

→ It has been proposed the existence of a complex network of RNA•RNA interactions that govern the control of the essential viral processed and the switch among them.

Functional genomic RNA domains are firm candidates as antiviral targets. Interfering with their functioning by either the altering their proper folding or competing RNA-RNA interactions offers a potential means of developing antiviral strategies.



5th International Electronic Conference
on Medicinal Chemistry
1-30 November 2019

sponsors:   pharmaceuticals

Introduction: The 3' UTR of the WNV genome

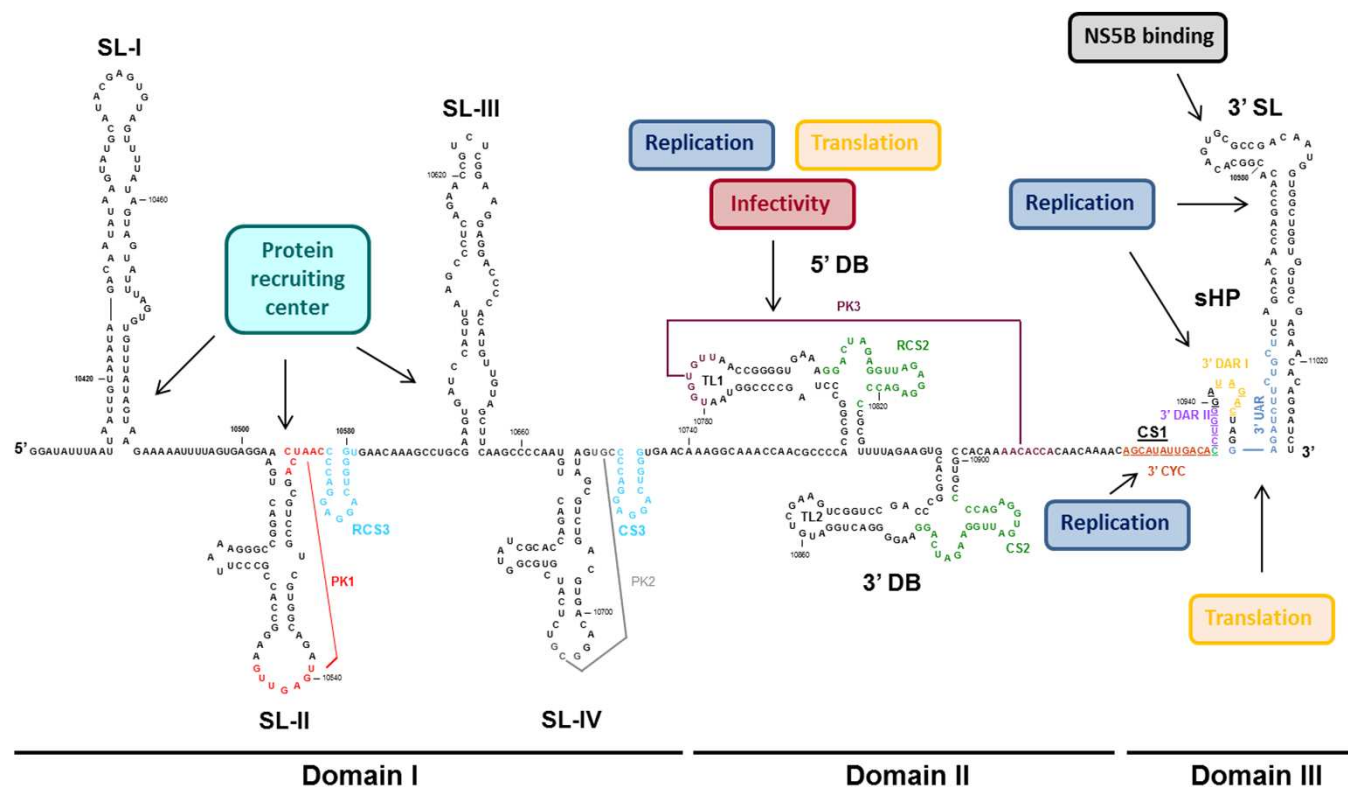

- The 3' UTR of the WNV genome is essential for viral replication, translation and infectivity.
- It can be subdivided into three autonomously folded domains
- A defining feature within this region is the presence of duplications of structural cassettes, which have different roles in viral replication. The duplicated structural elements seem to be related to the viral capacity for replicating in two different hosts, mammals and arthropods.



5th International Electronic Conference
on Medicinal Chemistry
1-30 November 2019

sponsors:   pharmaceuticals

Introduction: Role of the 3' UTR in the WNV translation

- We have recently shown that hepatitis C virus (HCV), a closely related virus belonging to the family *Flaviviridae*, recruits the ribosomal subunit 40S by a highly conserved structural RNA element placed at the 3' end of the viral genome.
- In this work, we have studied whether the 3' UTR of the WNV genome recruits the ribosomes as a means to regulate the viral translation.



5th International Electronic Conference
on Medicinal Chemistry
1-30 November 2019

sponsors:   pharmaceuticals

Does the 40S ribosomal subunit bind to the WNV-3'UTR?

1. Isolation of 40S ribosomal subunit.

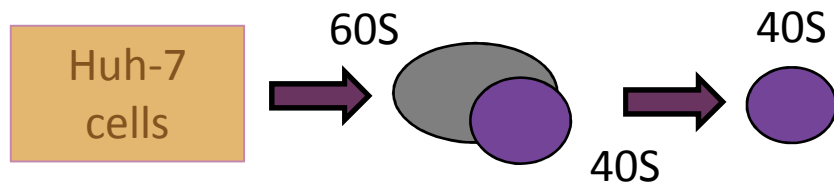

2. Synthesis of 3'WNV-1 RNA.

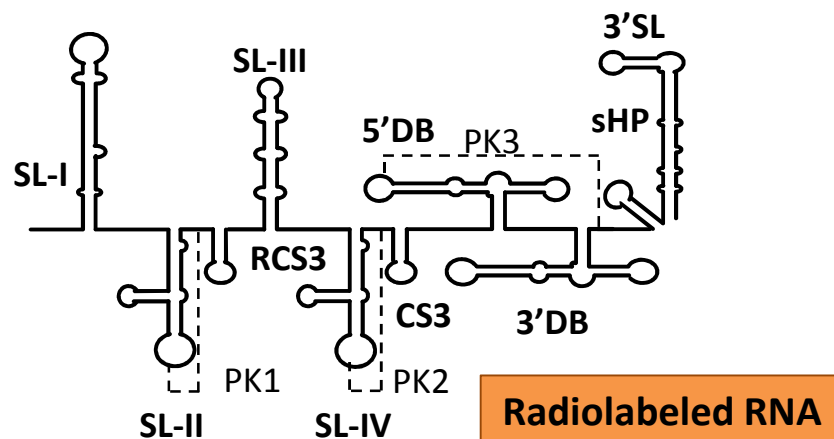

3. Incubation of 3'WNV-1 with 40S.

4. Double differential filter retention.

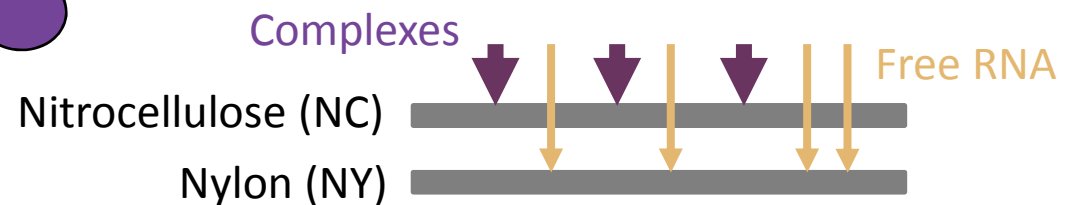

5. Quantification.

[40S] 50 nM

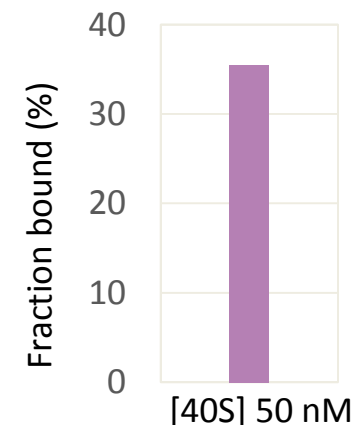

An internally [α - 32 P]-UTP labeled RNA fragment (named 3'WNV-1) containing the last 635 nucleotides of the WNV genome was incubated with purified 40S ribosomal subunits to allow the formation of ribonucleoprotein complexes. Subsequently, complexes were resolved by double differential filter retention. Results proved that the 40S subunit interacts with the viral 3'UTR region in the absence of any other factors.



5th International Electronic Conference
on Medicinal Chemistry
1-30 November 2019

sponsors:   pharmaceuticals

Biochemical characterization of the 3'UTR-40S binding.

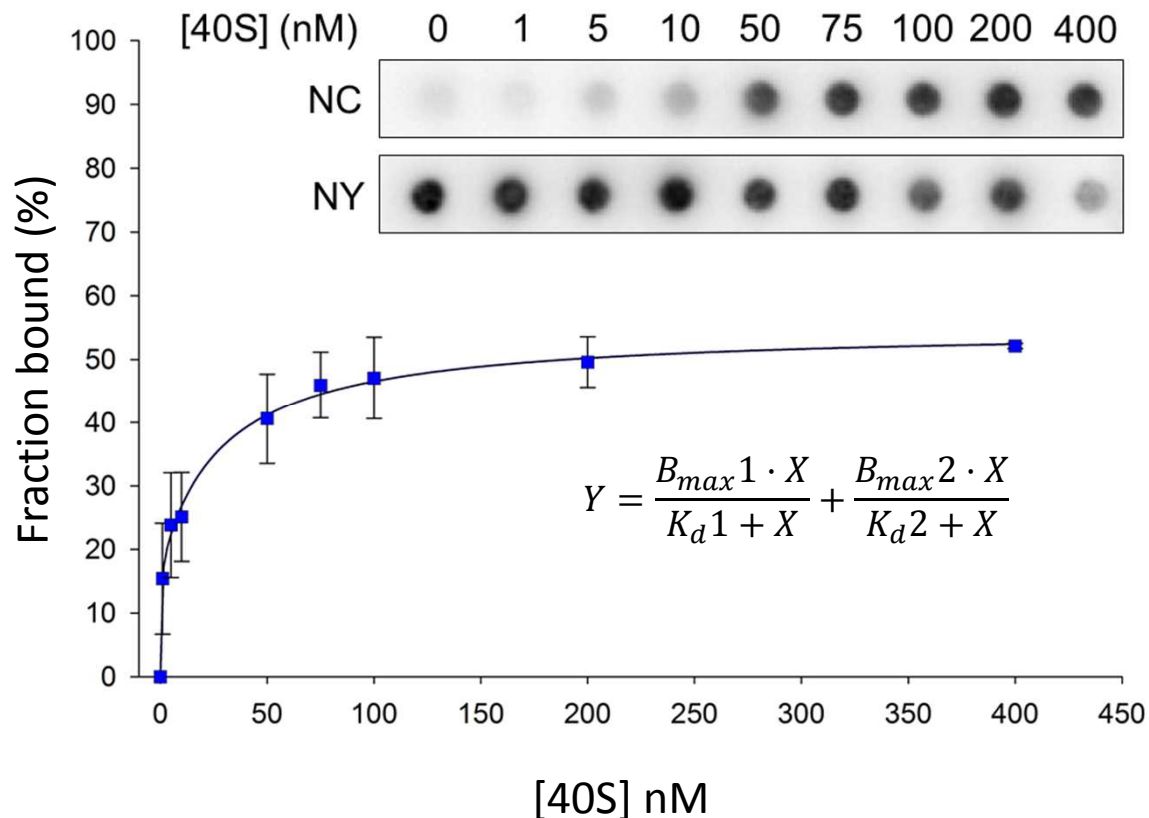

Two 40S ribosomal subunit binding sites ...

	K_d	B_{max}
Site 1	0,23 nM	17,64%
Site 2	28,83 nM	37,29%

... with really different characteristics.

Once binding of the 40S ribosomal subunit to the 3'UTR of WNV was verified, binding assays were performed at different 40S subunit concentrations to determine the binding affinity. Two putative binding sites in the 3'UTR were determined. Each of these binding sites exhibits different affinity (K_d) and reaction yield (B_{max}).



5th International Electronic Conference
on Medicinal Chemistry
1-30 November 2019

sponsors:   pharmaceuticals

Identification of the WNV-3'UTR nucleotides involved in 40S binding

Selective 2'-hydroxyl acylation analyzed by primer extension (SHAPE)

1. Electrophilic reagent treatment.

2'-OH ribose modifications

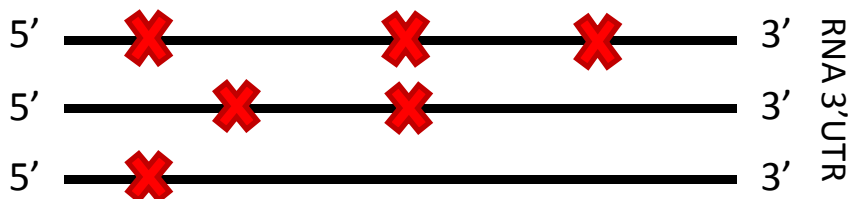

2. Retrotranscription.

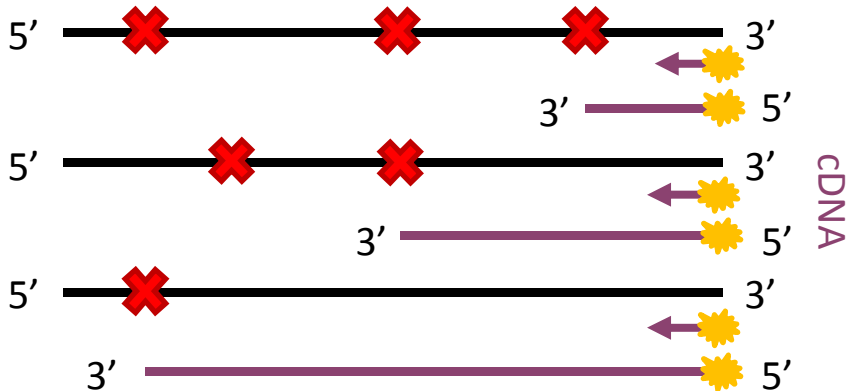

3. Capillary electrophoresis.

NMIA

Nucleotides with fast electronic dynamics.

1M6

Nucleotides with slow electronic dynamics.

4. Signal quantification: QuShape.

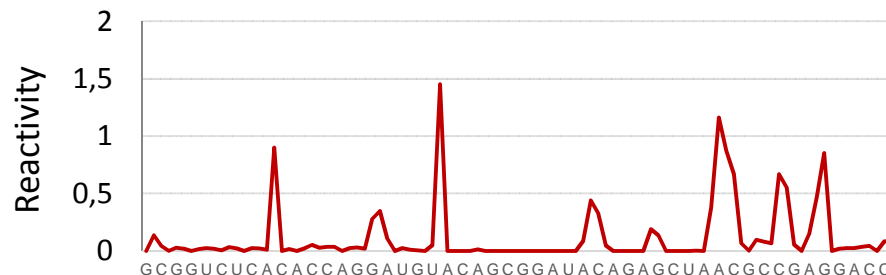

SHAPE assays were performed to find out the 3'UTR nucleotides involved in the recruitment of the 40S subunit. This methodology uses electrophilic reagents capable of modifying nucleotides dependent on their flexibility. Modified nucleotides act as stop signals during retrotranscription. Resulting cDNA molecules show different lengths corresponding to the modified positions in the template. The modified nucleotides are subsequently revealed by capillary electrophoresis.



Identification of the WNV-3'UTR nucleotides involved in 40S binding

1- Comparison of the electrophoretic profiles resulting from the 1M6 treated molecules pre-incubated and non pre-incubated with 40S reveals residues involved in the interaction. Binding of 40S subunit prevents nucleotides from being modified by SHAPE reagents.

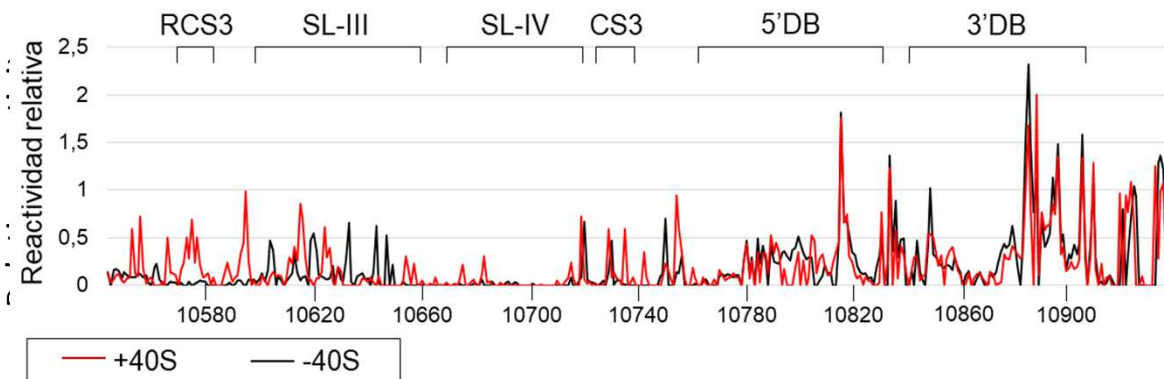

1M6 assay

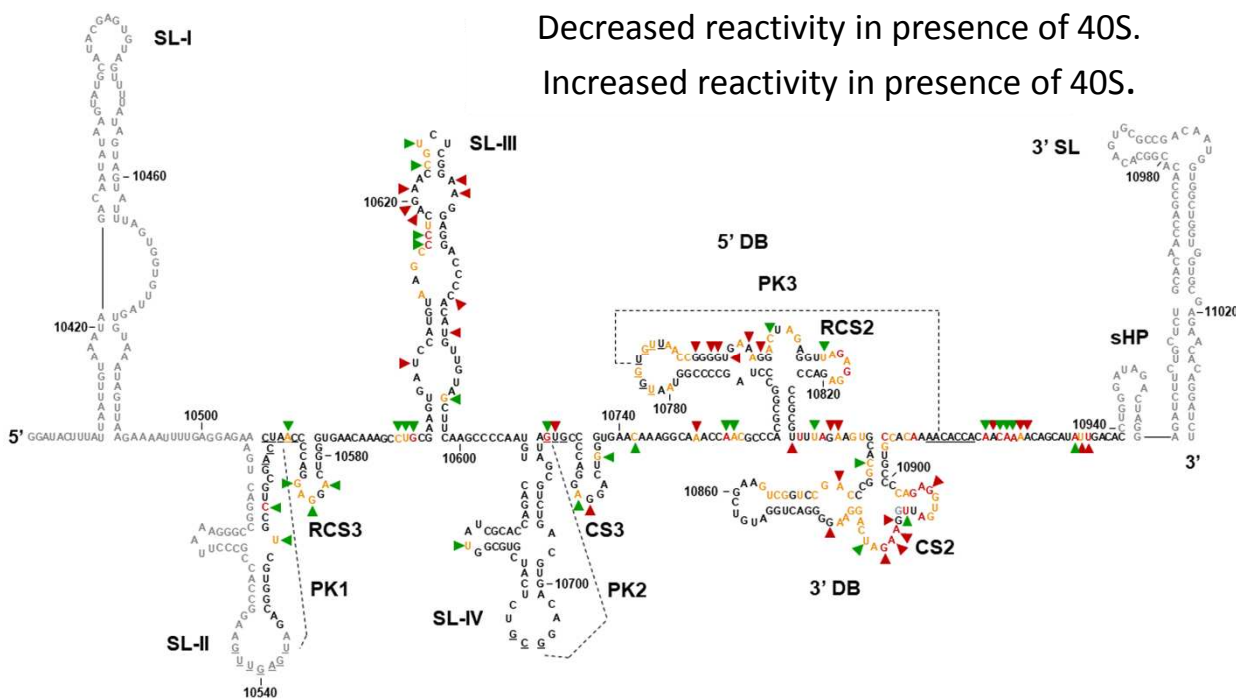

Decreased reactivity in presence of 40S.
Increased reactivity in presence of 40S.

2- The SHAPE test detected three main groups of low reactive nucleotides (red arrows). Two of them are located in the 5' and 3' DB elements, while the third one maps in the internal loop of SL-III element. These nucleotide groups constitute firm candidates to be 40S subunit binding sites.



Identification of the WNV-3'UTR nucleotides involved in 40S binding

NMIA assay

1- Reactivity increased in numerous positions of the 3'DB domain and its downstream region as result of the 40S binding. This demonstrates the implication of these nucleotides in the interaction.

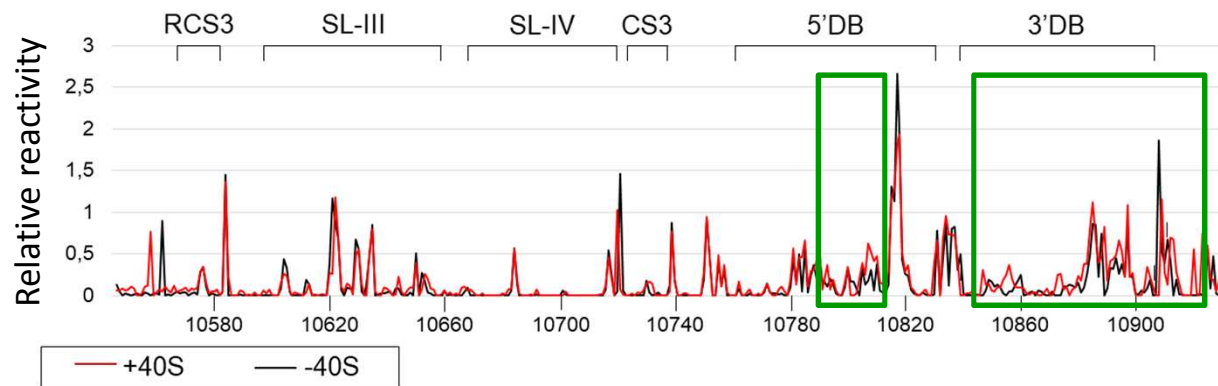

- ▼ Decreased reactivity in presence of 40S.
- ▲ Increased reactivity in presence of 40S.

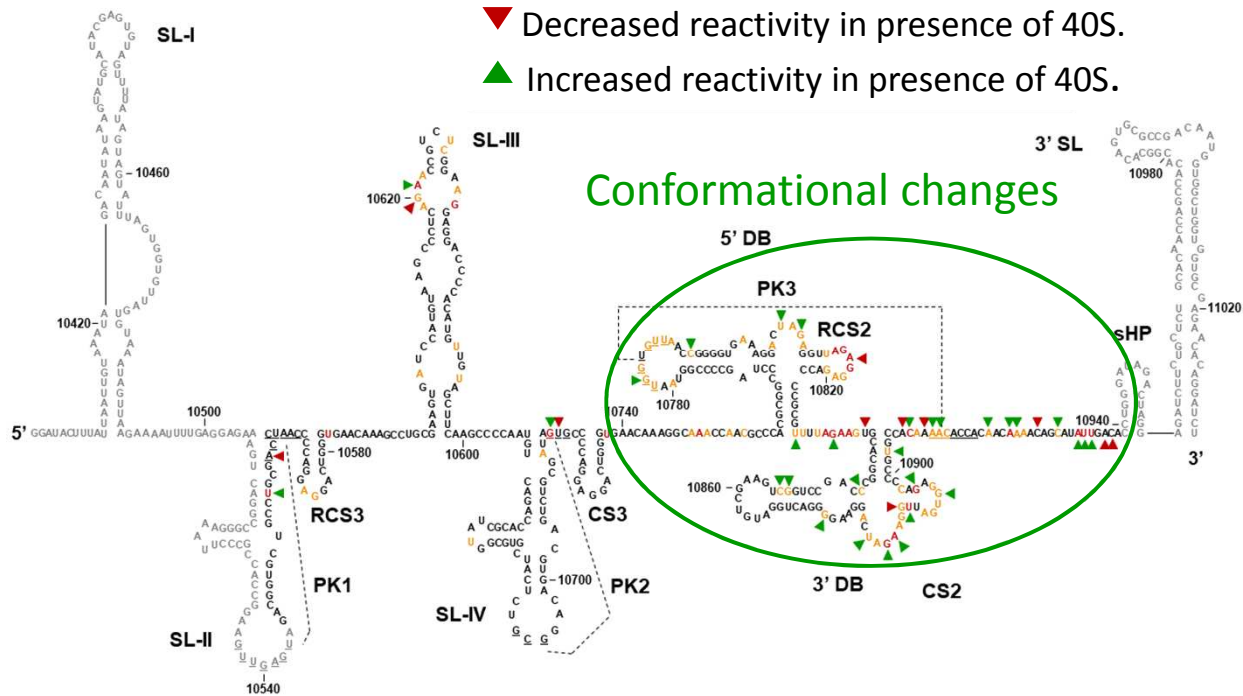

2- The conformational dynamics observed in the SL-III element and in the fragment encompassing the double DB suggest that structural transitions can occur in these domains. This would allow them to act as organizing centers for three-dimensional structure at the 3' end of the viral genome as well as recruitment sites for protein factors.



Which are the minimum regions necessary for the interaction?

Affinity assays with sequentially shortened 3'UTR mutants from its 3' end

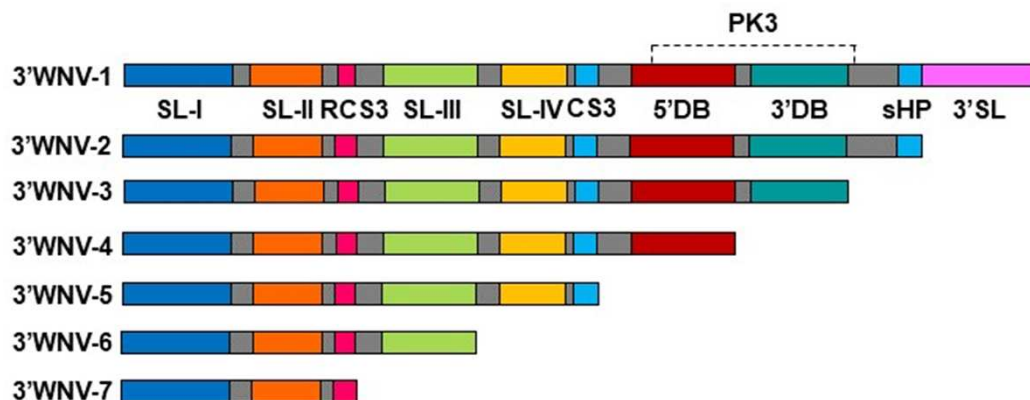

The results of the affinity tests suggest that the binding site with high affinity (Site 1) for 40S is located in 3' of the 3'DB domain while the binding site with low affinity (Site 2) would map in 5' of the SL-III element.

For the whole 3'UTR region, the 3'SL element prevents blocking of the Site 2 by the 3'DB element. However, in absence of the 3'SL element, the 3'DB domain undergoes a conformational change resulting in blocking the 40S binding (3'WNV-3). Additional deletion of the 3'DB element would make site 2 available for 40S binding again (3'WNV-4).

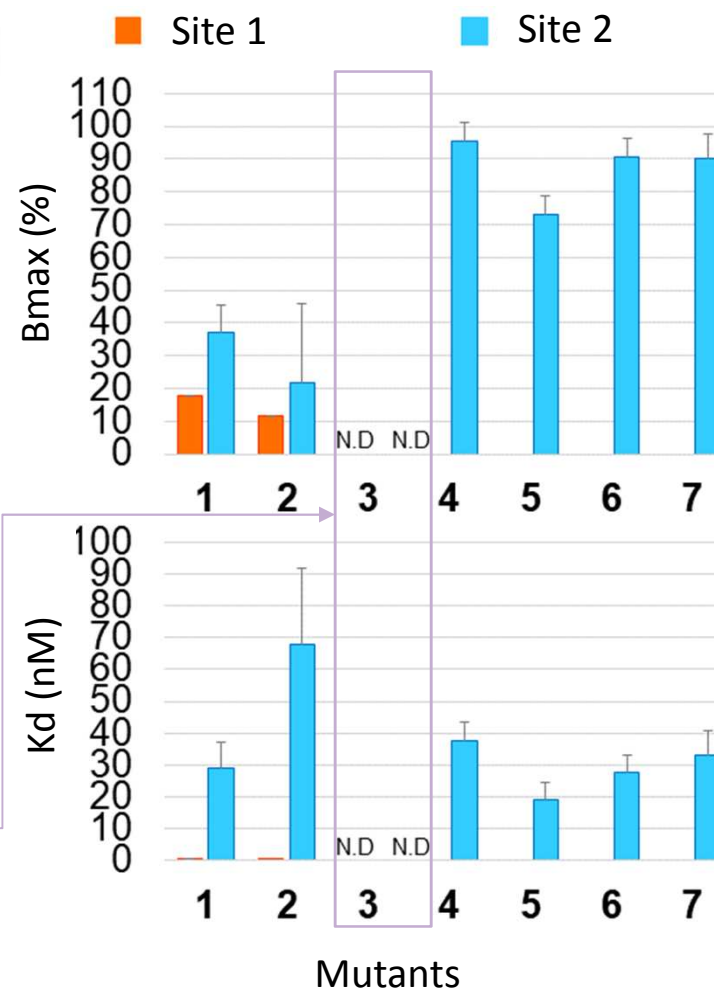

The WNV-3'UTR is required for an efficient translation

Translational efficiency assays of mutant subgenomic viral RNAs in *Vero* cells

1. Synthesis of WNV RNA molecules

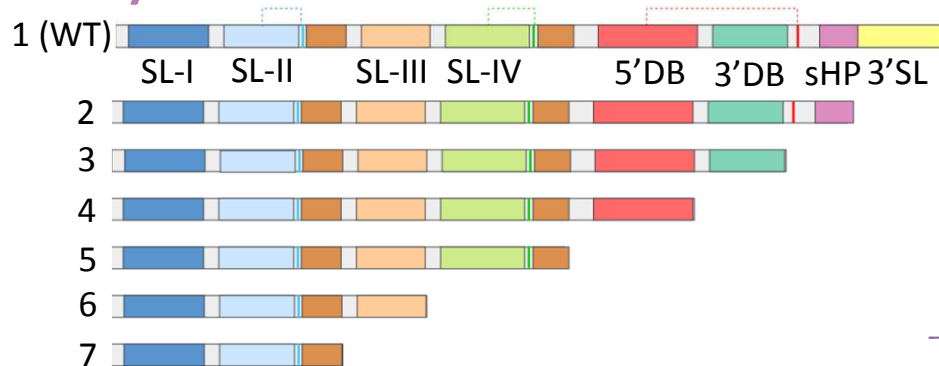

2. Transfection

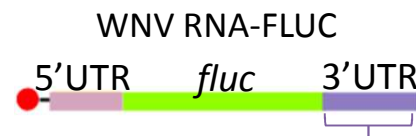

Transfection internal control
(RNA RLUC)



Vero cells were cotransfected with the seven WNV RNA-Fluc constructs used in the above affinity assays and the internal transfection control RNA-RLUC. After 4-h post-transfection, cells were lysated and luciferase measurements were performed.

3. Quantification of Fluc and Rluc activity

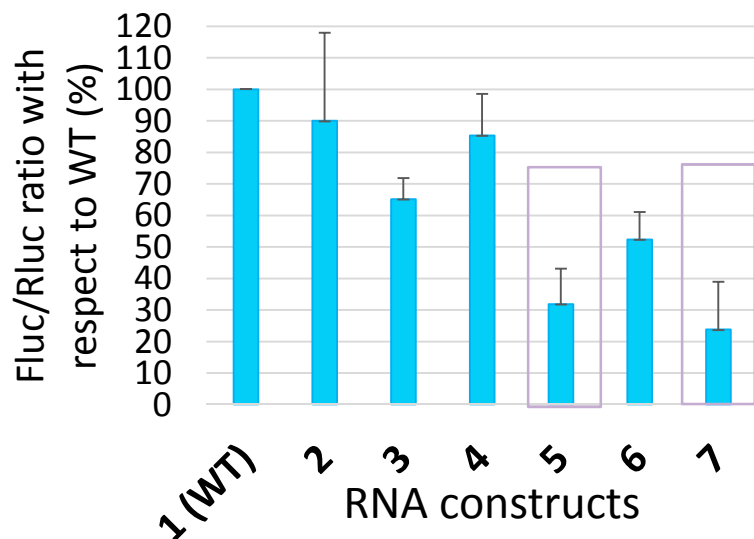

The results of the functional assays show a general decrease of translational efficiency when the 3'UTR is shortened from its 3' end. A remarked effect was observed in RNA constructs 5 and 7, where 5'DB and SL-III are absent, respectively.

This is consistent with the results of the affinity assays, where a decrease in ribonucleoprotein complex formation is observed when the DB element is removed (RNA 5). Furthermore, SL-III has been shown to be associated with the binding of 40S subunit, so the decrease observed in mutant 7 could be the result of impairing Site 2 spatial conformation.



Effect of individual elements in WNV-3'UTR on viral translation

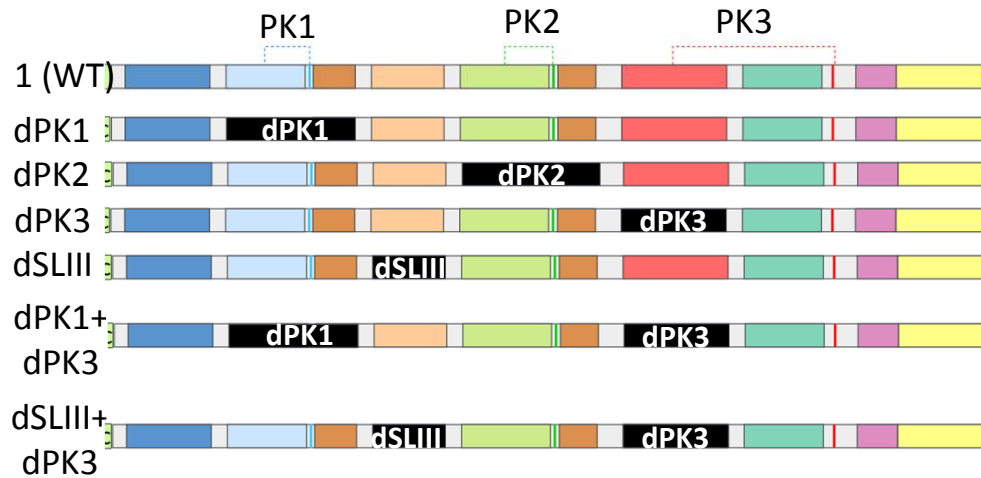

The translational efficiency of subgenomic RNA molecules with deletions in specific functional elements agrees with the previous results, and supports the hypothesis of SLIII and DB elements being essential for translation of viral genomic RNA.

The dSLIII+dPK3 RNA construct, which lacks of both SLIII and 5'DB elements, generates a reduction of translational efficiency. This reduction shows a similar extent to that exhibited by the RNA construct lacking the whole 3'UTR. This observation suggests the importance of the 3'UTR in maintaining viral translational efficiency in WNV subgenomic RNA molecules.

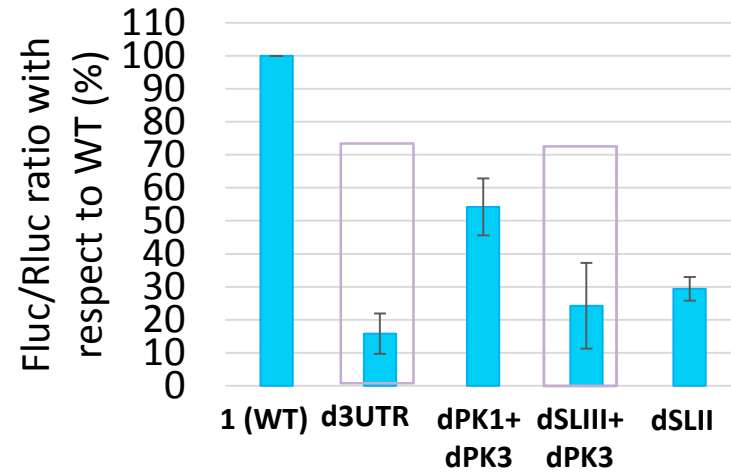
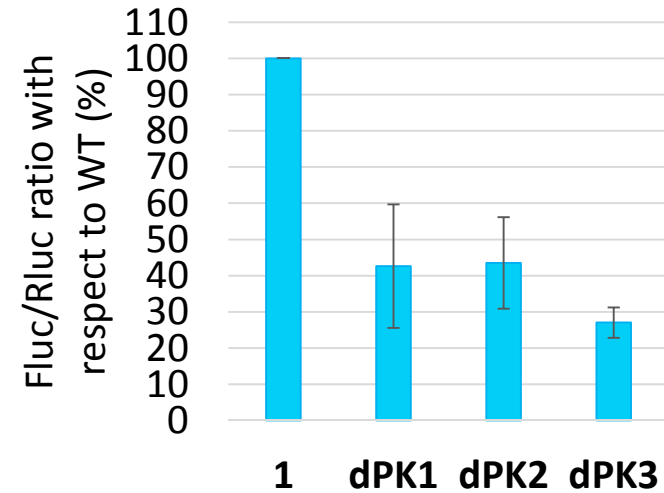

Conclusions

The 3'UTR of the WNV RNA genome is required to ensure efficient translation

Deletion of the highly conserved 3'UTR structural elements 5'DB and SL-III leads to the abolition of viral translation.

The 3'UTR of the WNV recruits the 40S ribosomal subunit efficiently.

We have identified at least two putative binding sites of the 40S subunit within the 3'UTR, which are located at the 5' of the SL-III element and the 3' nucleotides of the PK3 element., which interact with nucleotides within the 5'DB element.

SL-III and 5'DB constitute potential candidates for the development of strategies to fight against WNV infection. Interfering with their appropriate folding offers a potential means to disrupt the viral translation.



5th International Electronic Conference
on Medicinal Chemistry
1-30 November 2019

sponsors:   *pharmaceuticals*

Acknowledgments



Una manera de hacer Europa



5th International Electronic Conference
on Medicinal Chemistry
1-30 November 2019

sponsors:



pharmaceuticals