

# **Modelling biocontrol agents as plant protection tools**

**Giorgia Fedele<sup>1</sup>, Federica Bove<sup>2</sup>, Elisa González-Domínguez<sup>2</sup> and Vittorio Rossi<sup>1,\*</sup>**

<sup>1</sup> Department of Sustainable Crop Production, Università Cattolica del Sacro Cuore, Via Emilia Parmense, 84, 29122 Piacenza, Italy ;

<sup>2</sup> Horta s.r.l., Via Egidio Gorra 55, 29122 Piacenza, Italy.

\* Corresponding author: [vittorio.rossi@unicatt.it](mailto:vittorio.rossi@unicatt.it)



# Biocontrol of plant pathogens

Biocontrol: use of biocontrol agents or BCAs (fungi, bacteria, yeasts, or viruses) that may suppress plant pathogens via competition for nutrients or space, antibiosis, parasitism, and induced host plant resistance.



- ✓ A sustainable method of disease management;
- ✓ A viable way to reduce the application of chemicals in agriculture;
- ✓ The global reliance on BCA use remains relatively insignificant.

## Advantages

- Good efficacy, if used properly
- Low eco-toxicological risk
- Mode of actions useful for the resistance management
- Short pre-harvest interval
- Low residues level

## Disadvantages

- Lower efficacy than chemicals
- Variable efficacy based on application conditions
- Preventative
- Specific requirements and short shelf-life
- May not compatible with chemicals

## Opportunity

- Allowed in organic farming
- Can be used in flowering
- Better management of intervals

## Challenges

- Increase of efficacy if used in a less disease conducive environment
- More knowledge and decision processes are needed

Reason for poor and/or inconsistent efficacy in the field

- ✓ BCAs are often used in a similar manner as fungicides;
- ✓ Factors influencing fitness and efficacy of biocontrol microorganisms are not fully known;
- ✓ The complex relationships between BCAs and the environment remain difficult to predict and manage;

Mathematical models can help understanding complex and dynamic interactions among a target pathogen, host plants, and the BCA population in a changing environment.

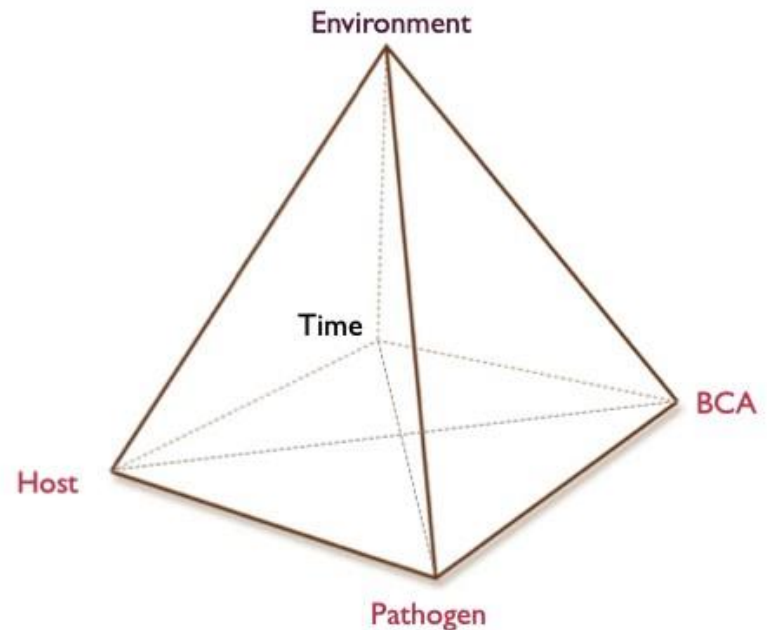

A model able to predict the likelihood of the successful control of foliar diseases by a single BCA as a function of the biocontrol mechanisms involved.

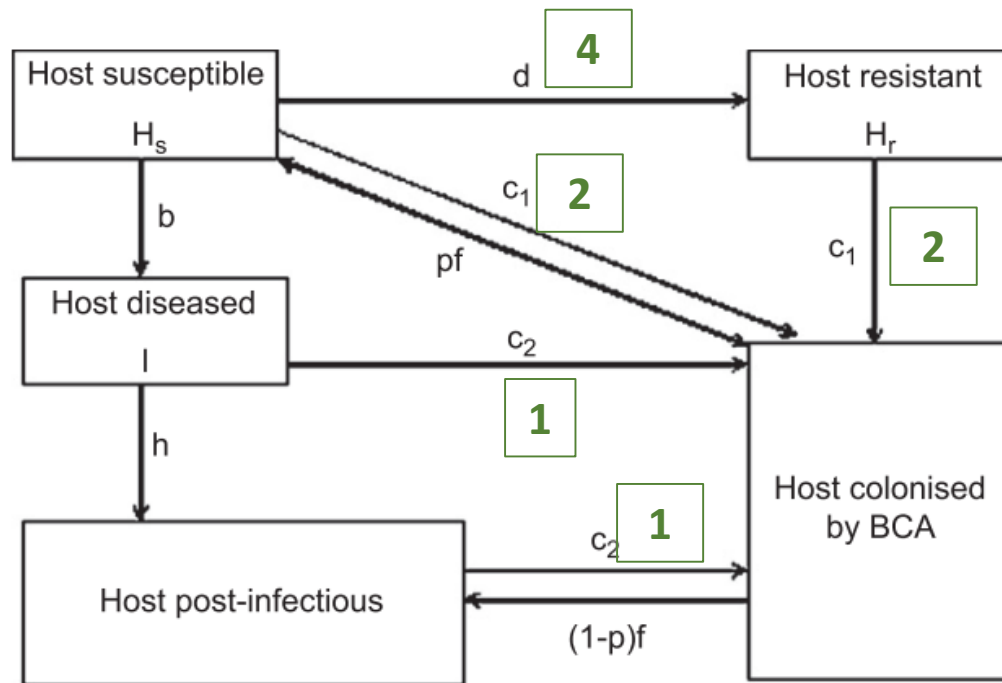

Host–pathogen dynamics are coupled with pathogen–BCA dynamics through four biocontrol mechanisms:

1. mycoparasitism;
2. competition;
3. antibiosis;
4. induced plant resistance.

## Model development

The model proposed by Jeger et al. (2009) was enlarged by including:

- ✓ The effects of environmental conditions on the interactions between the pathogen and BCA;
- ✓ The dynamics of host growth and senescence.

The model is generic: can be operated for fungal pathogens and for BCAs with different mechanisms of action (MOA).

The model was developed by using the software STELLA®

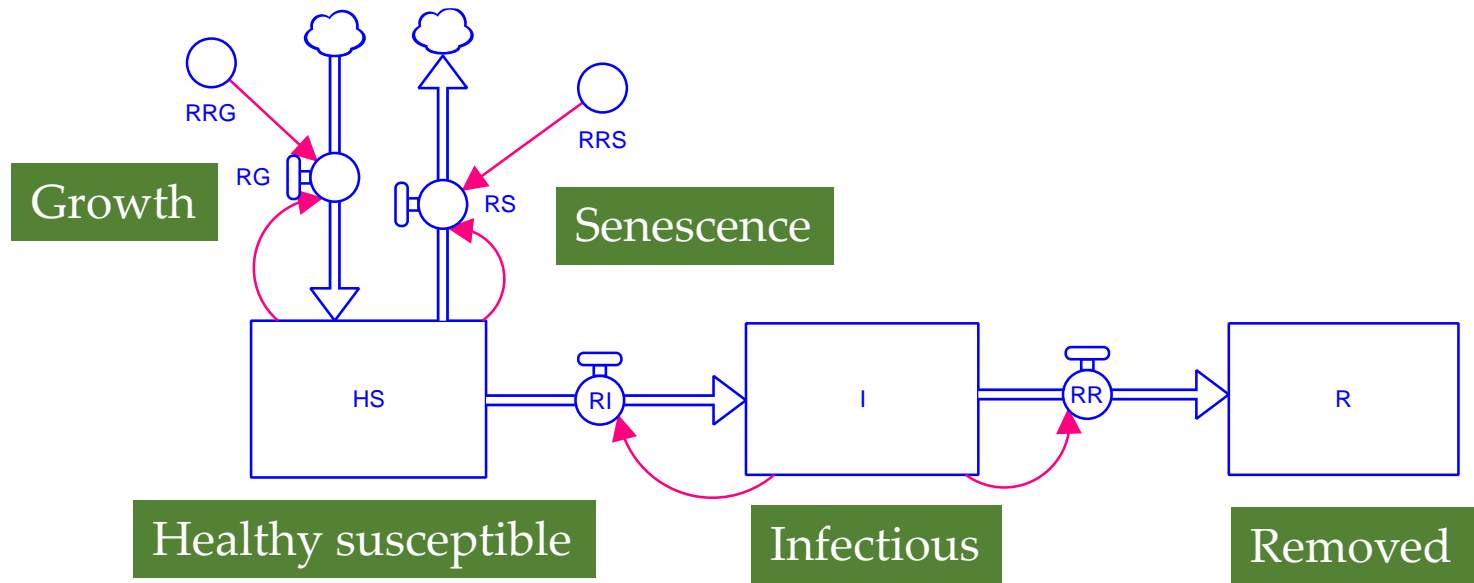

State variables represent plant tissue categories.

Host processes (growth and senescence) are also represented.

# The pathogen-BCA dynamics on plant tissue according to mechanisms of action (MOA)

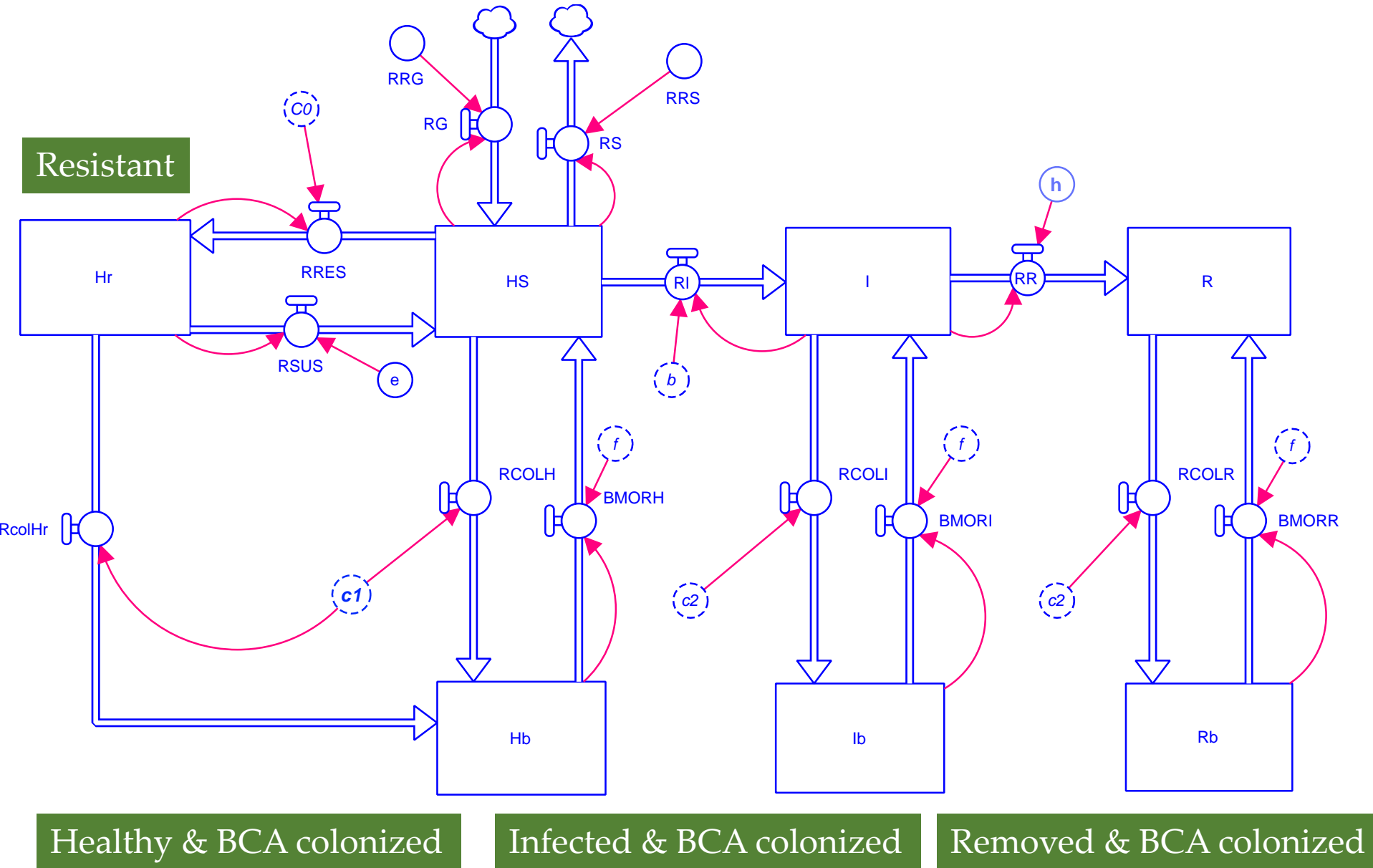



# The pathogen-BCA dynamics on plant tissue according to mechanisms of action (MOA)

1. mycoparasitism;
2. competition;
3. antibiosis;
4. induced plant resistance.

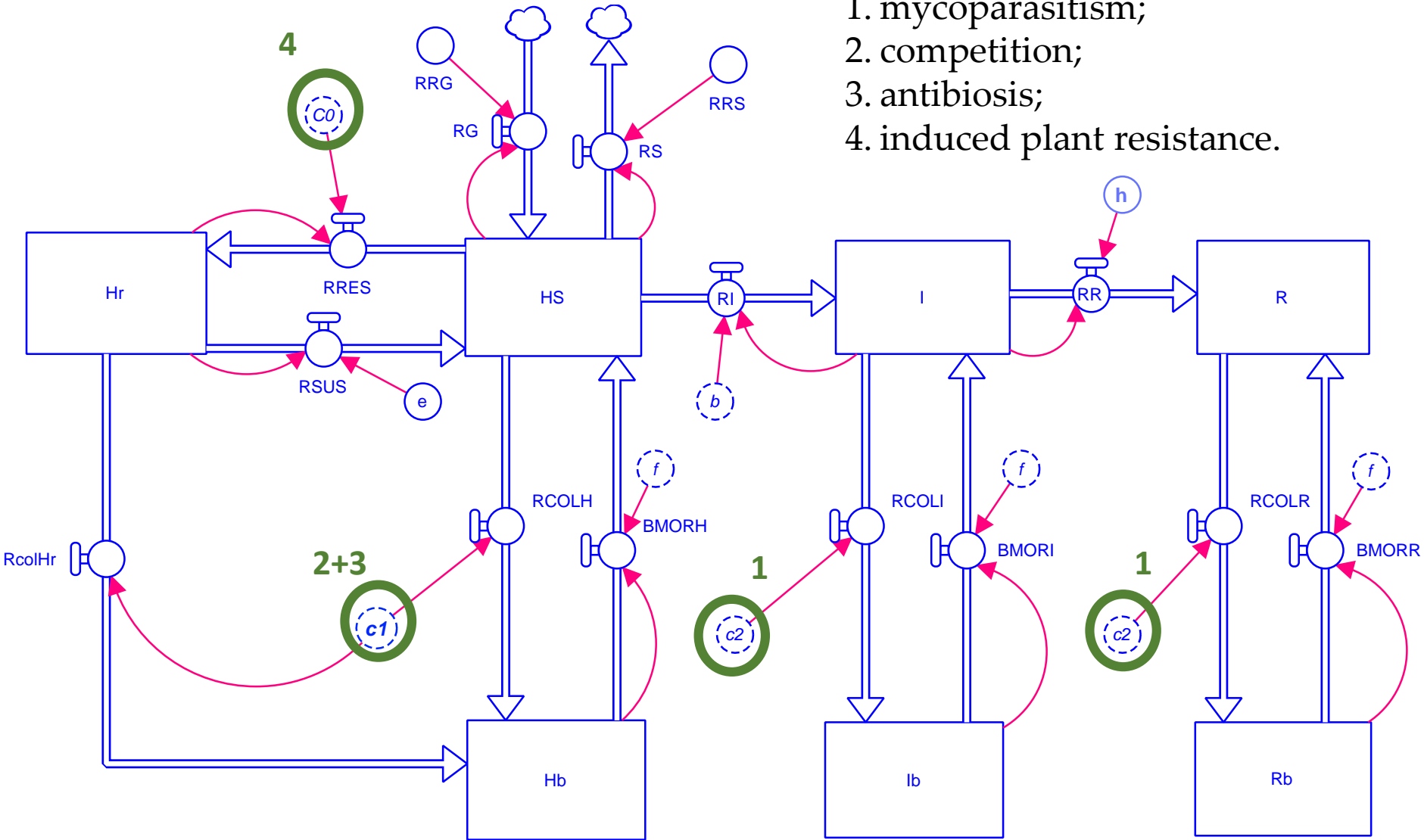

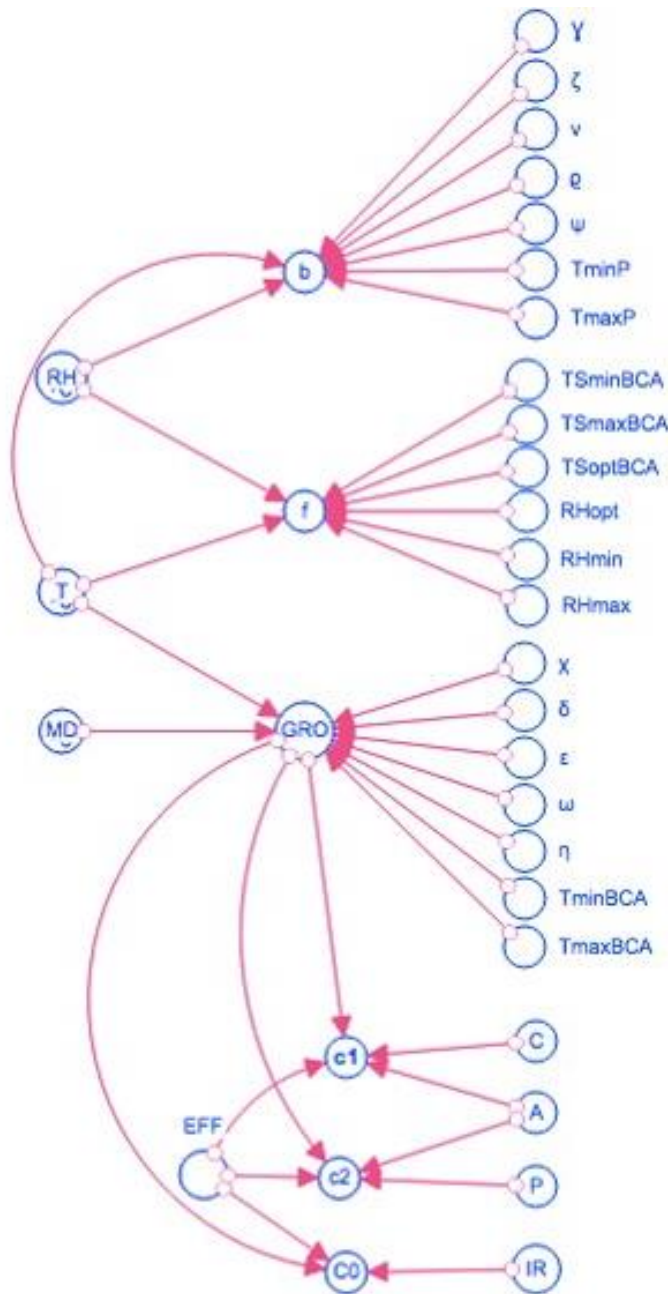

Driving variables determine the relative rate of change of the system as influenced by external variables

Pathogen infection rate is influenced by temperature and relative humidity

$$b_t = (\alpha \times Teq_t^\beta \times (1 - Teq_t))^\theta \times \exp^{-\vartheta \times \exp(-\zeta \times MD_t)}$$

BCA growth rate is influenced by temperature and moisture

$$GRO = (\gamma \times Teq_t^\zeta \times (1 - Teq_t))^\nu / \left(1 + \exp\left(\varrho - \psi \times \frac{RH_t}{100}\right)\right)$$

## Model parametrization



The model was parametrized for the *Botrytis cinerea*–grapevine pathosystem.

The model was parametrized for the biocontrol of BBR in grapevine clusters between “veraison” (GS83) and “berries ripe for harvest” (GS89).

- ✓ Temperature and moisture requirements for *B. cinerea* to cause infection;
- ✓ MoA of the BCA;
- ✓ Timing of BCA application with respect to the pathogen;
- ✓ Temperature and moisture requirements for BCA to grow and survive.

## Model running

The model was used to study the effect of the following sources of variation on BBR development:

- ✓ MOA of the BCA: mainly competition and mainly mycoparasitism;
- ✓ BCA application time (as preventative or curative);
- ✓ BCA strain: 3 ranges of temperatures combined with 3 moisture requirements for BCA growth;
- ✓ BCA survival capability: low, medium, and high.

... 981 model runs (1 NT + 108 BCA combinations) under 9 scenarios, reflecting three climate types: cold and wet, mild and semi-arid, and warm and dry.

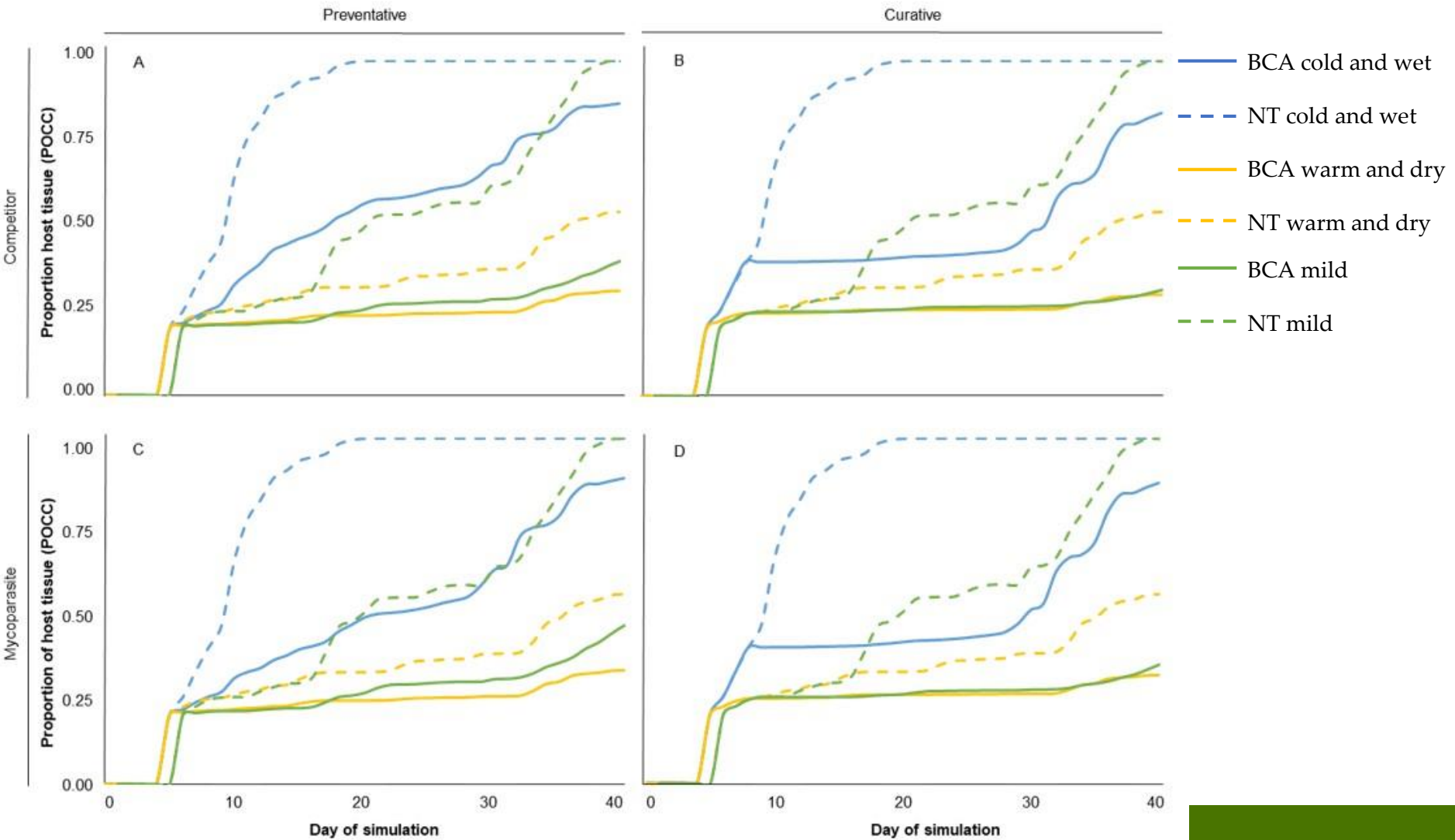

Total tissue occupied by the pathogen as affected by MOA, application time, and climate type.



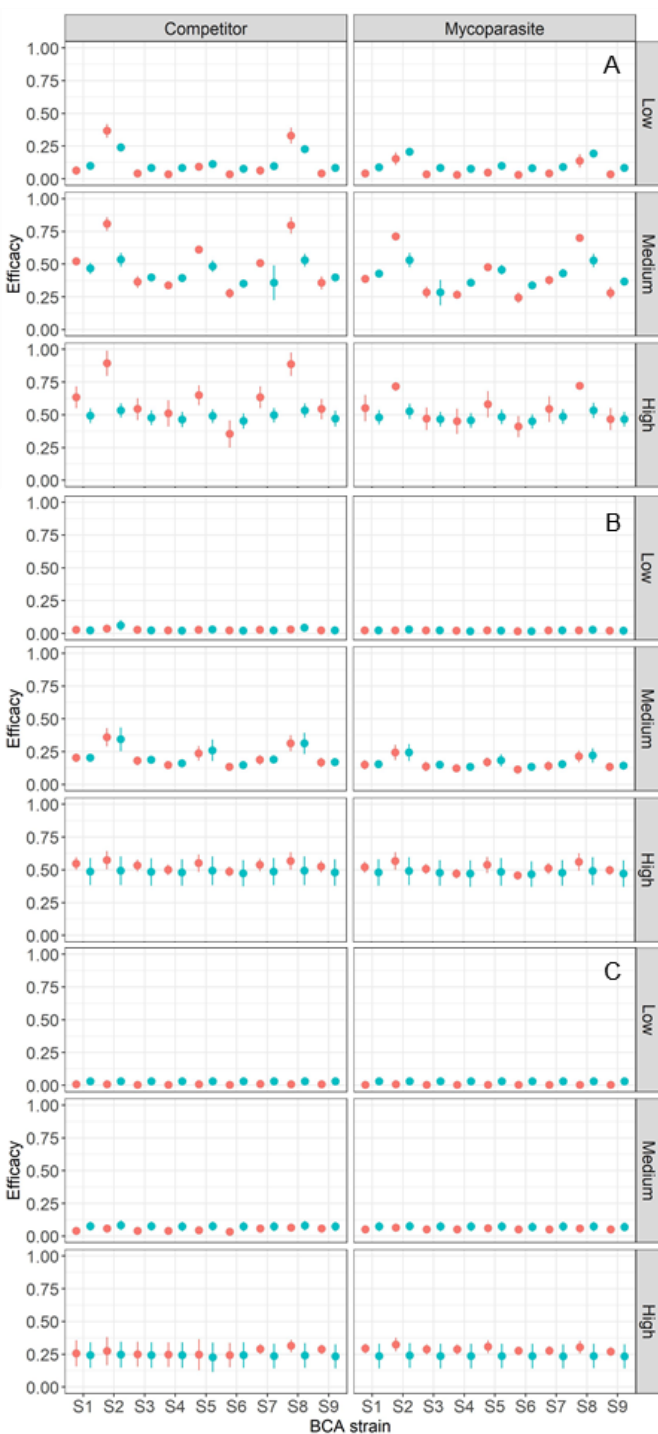

The final values of AUDPC simulated for each of the 981 runs of the model were used to calculate the efficacy (E) of each BCA combination (T) in relation to the untreated control (NT):

$$E = (NT - T) / NT.$$

BCA efficacy against Botrytis bunch rot in ripening grapevine clusters, as affected by MOA; responses of 9 BCA strains to temperature; BCA survival capability; and climate.

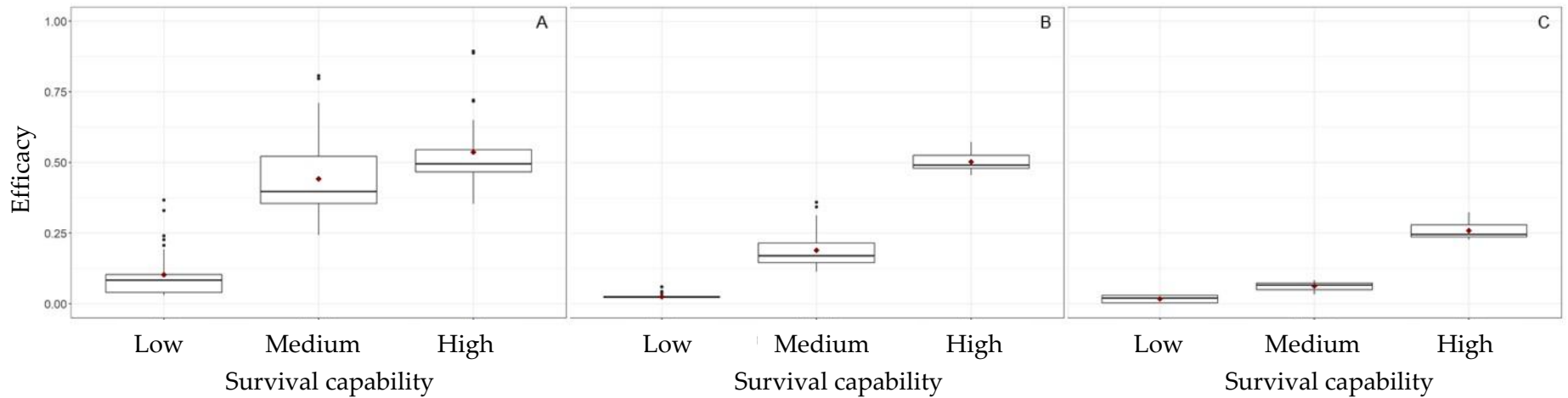

BCA efficacy against BBR in ripening grapevine clusters averaged across nine BCA strains and as affected by BCA survival capability and climate type: (A) cold and wet, (B) mild and semi-arid, and (C) warm and dry.

## BCA efficacy against Botrytis bunch rot in ripening grapevine clusters of nine BCA strains

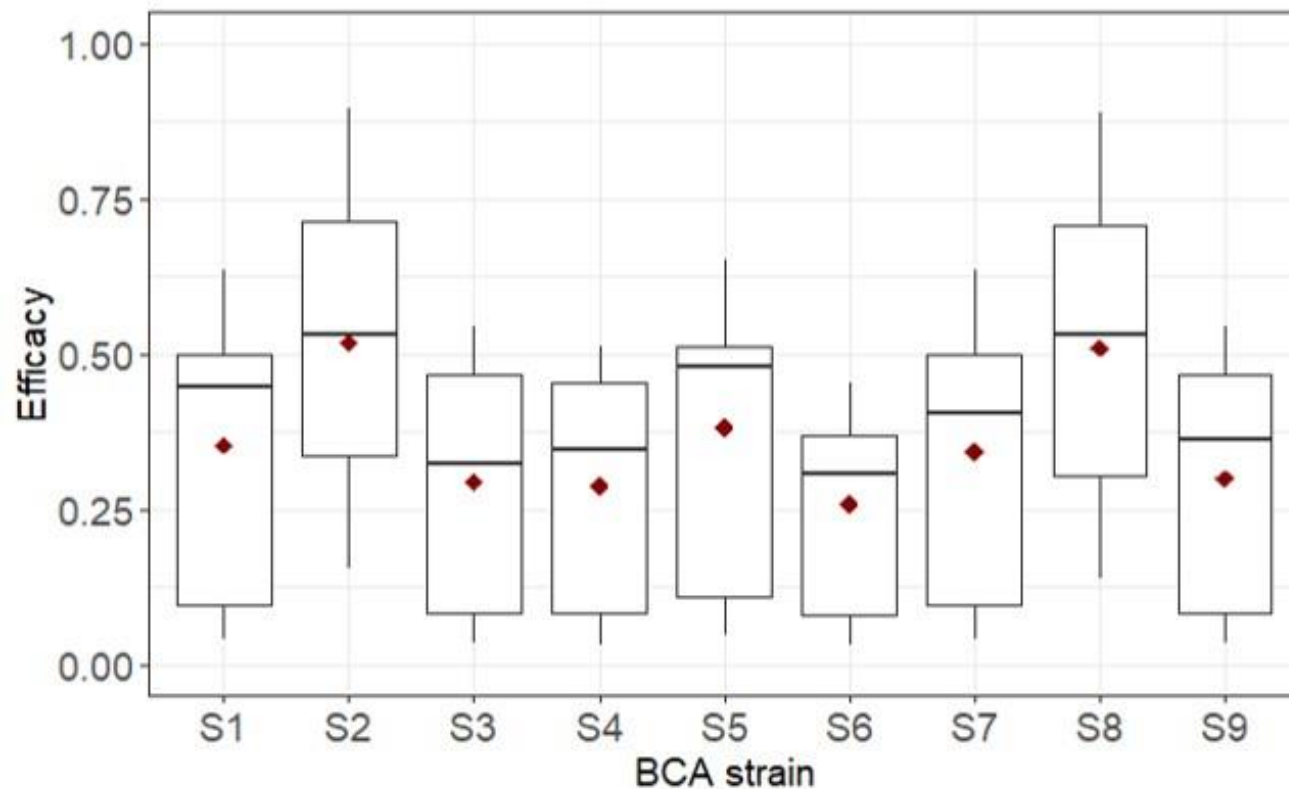

BCA response (growth and survival) to environmental conditions plays a prevalent role in their efficacy, accounting for > 90% of simulation variability.



## Conclusions

- ✓ Importance of considering the environmental response of the BCA during its selection;
- ✓ Importance of considering the BCA survival capability during both selection and formulation;
- ✓ Importance of considering the weather conditions and forecasts at the time of BCA application in the field.